

THIS FILE IS MADE AVAILABLE THROUGH THE DECLASSIFICATION EFFORTS AND RESEARCH OF:

THE BLACK VAULT

THE BLACK VAULT IS THE LARGEST ONLINE FREEDOM OF INFORMATION ACT / GOVERNMENT RECORD CLEARING HOUSE IN THE WORLD. THE RESEARCH EFFORTS HERE ARE RESPONSIBLE FOR THE DECLASSIFICATION OF THOUSANDS OF DOCUMENTS THROUGHOUT THE U.S. GOVERNMENT, AND ALL CAN BE DOWNLOADED BY VISITING:

[HTTP://WWW.BLACKVAULT.COM](http://www.blackvault.com)

YOU ARE ENCOURAGED TO FORWARD THIS DOCUMENT TO YOUR FRIENDS, BUT PLEASE KEEP THIS IDENTIFYING IMAGE AT THE TOP OF THE .PDF SO OTHERS CAN DOWNLOAD MORE!

MANHATTAN DISTRICT HISTORY

MDH-Book I - V.12 (Appendix)

104

BOOK I - GENERAL ✓

VOLUME 12 - CLINTON ENGINEER WORKS

CENTRAL FACILITIES

3A

~~CONFIDENTIAL~~

APPENDICES A, B, & C

MDH - Book I - V.12 - (Append.)

THIS DOCUMENT CONSISTS OF 180 PAGES
NO. 3 OF 4 SERIES A

~~CONFIDENTIAL~~

~~SECRET~~

CLASSIFICATION CANCELLED
OR CHANGED TO _____
BY AUTHORITY OF DOE/DPC
JOHN K. [signature] DATE 9/5/79
REVIEWED BY _____

CLASSIFICATION CHANGED TO
~~CONFIDENTIAL~~
DATE 10-1-54
-H. F. Caswell
Chief, Declassification Branch

~~CONFIDENTIAL~~

~~RESTRICTED DATA~~

This document contains information as defined in the Atomic Energy Act of 1954. Its disclosure or the disclosure of its contents in any manner to an unauthorized person is prohibited.

ORO 89102

179

~~SECRET~~

~~CONFIDENTIAL~~

MANHATTAN DISTRICT HISTORY

BOOK I - GENERAL

VOLUME 12 - CLINTON ENGINEER WORKS, CENTRAL FACILITIES

DECLASSIFIED BY *JRW* 9/5/79
 BY *DDE/DFC*
 Date of Review 10/17/05
 DD, SO-10.23

~~CONFIDENTIAL~~

~~SECRET~~

~~CONFIDENTIAL~~
 Atomic Energy Act of 1946
 Specific Restricted Data
 Clearance Required

~~SECRET~~
~~CONFIDENTIAL~~

MANHATTAN DISTRICT HISTORY

BOOK I - GENERAL

VOLUME 12 - CLINTON ENGINEER WORKS, CENTRAL FACILITIES

APPENDIX A - FILE REFERENCES

~~SECRET~~
~~RESTRICTED DATA~~
Atomic Energy Act 1946
Specific Restricted Data
Clearance Required

MANHATTAN DISTRICT HISTORY

BOOK I - GENERAL

VOLUME 12 - CLINTON ENGINEER WORKS, CENTRAL FACILITIES

APPENDIX A - FILE REFERENCES

<u>No.</u>	<u>Description</u>	<u>Location</u>
1	Report of 13 June 1942 to the President of the United States by Dr. Vannevar Bush, Director, Office of Scientific Research and Development	Classified Files, Major General L. R. Groves, Washington, D. C.
2	Delegation of Authority under Executive Order No. 9001 to Major General L. R. Groves from the Under Secretary of War	Classified Files, Major General L. R. Groves, Washington, D. C.
3	Delegation of Authority under Executive Order No. 9001 from Major General L. R. Groves to the District Engineer	Manhattan District Classified Files, Oak Ridge, Tennessee
4	Memorandum, signed by the ^{Top} General Policy Group, dated 23 September 1942 ↑ <u>Committee</u>	Classified Files, Major General L. R. Groves, Washington, D. C.
5	Record of Conference of Policy Committee at Clinton Engineer Works, 22 and 23 January 1944	Classified Files, Major General L. R. Groves Washington, D. C.
6 ✓	Cost Estimate, CEW Central Facilities, prepared by Stone & Webster Engineering Corporation, dated 31 March 1945	Manhattan District Classified Files, Oak Ridge, Tennessee
7	Military Appropriations Act, 1943	
8 ✓	Completion Report, Portion of Town-site Planning of Oak Ridge, Tennessee, Covered by Contract No. W-7401-eng-69, Sidmore, Owings & Merrill, Architect-Engineer, Oak Ridge, Tennessee, 9 September 1944	Manhattan District Classified Files, Oak Ridge, Tennessee

<u>No.</u>	<u>Description</u>	<u>Location</u>
9 ✓	Manhattan District Diary (Original), Page 10	Manhattan District Classified Files, Oak Ridge, Tennessee
10 ✓	Manhattan District Diary (Original), Page 73	Manhattan District Classified Files, Oak Ridge, Tennessee
11	<i>Deleted</i>	
12 ✓	Letter, dated 21 November 1942 (Concerning scope of work of Stone & Webster Engineering Corporation)	Manhattan District Classified Files, No. 624, Oak Ridge, Tennessee
13 ✓	Letter to Stone & Webster Eng- ineering Corporation, dated 17 February 1943	Manhattan District Classified Files, Oak Ridge, Tennessee
14 ✓	Contract No. W-7405-eng-77, with the John B. Pierce Foundation	Manhattan District Contract Files, Oak Ridge, Tennessee
15 ✓	Memorandum, D. C. Moore to Files, 17 February 1943	Manhattan District Classified Files, No. 337, Oak Ridge, Tennessee
16 ✓ ✓	Contract No. W-7401-eng-29 with Skidmore, Owings & Merrill, Architect-Engineer	Manhattan District Contract Files, Oak Ridge, Tennessee
17 ✓ ✓	Contract No. W-7401-eng-69, with Skidmore, Owings & Merrill, Architect-Engineer	Manhattan District Contract Files, Oak Ridge, Tennessee
18 ✓ ✓	Contract No. W-17-028-eng-53, with Skidmore, Owings & Merrill, Architect-Engineer	Manhattan District Contract Files, Oak Ridge, Tennessee
19 ✓	Roane-Anderson Company Operations Reports	Manhattan District Classified Files, No. W. D. 600.91, Oak Ridge, Tennessee

<u>No.</u>	<u>Description</u>	<u>Location</u>
19b ✓	Files, Material and Equipment Section, Department of Public Works, Manhattan District	Material and Equipment Section, Department of Public Works, Manhattan District, Oak Ridge, Tennessee
20 ✓	Letter, American Industrial Transit, subject: "Net Cash Cost to the Government for AIT Bus Operations", dated 23 January 1947, file: 121.6 (AIT)	Files, Control Department, Facilities and Service Division, Manhattan District, Oak Ridge, Tennessee
21 ✓	Letter, Stone & Webster Engineering Corporation to District Engineer, subject: "Townsite Stores and Other Services", dated 5 January 1943	Manhattan District Files, Oak Ridge, Tennessee
22 ✓	Concession Agreement No. RA-227, Roane-Anderson Company with J. Saunders Thompson and Robert H. Watkins	Files, Concessions and Subcontracts Section, Facilities and Service Division, Manhattan District, Oak Ridge, Tennessee
23 ✓	Negotiations Form for Contract No. W-7401-eng-115, with Roane-Anderson Company	Manhattan District Contract Files, Oak Ridge, Tennessee
24 ✓	Contract No. W-7401-eng-115, with Roane-Anderson Company	Manhattan District Contract Files, Oak Ridge, Tennessee
24a ✓	Memorandum to the Files from Colonel K. D. Nichols, dated 2 August 1945, explaining basis for choice of Roane-Anderson and determination of Fee-Contract No. W-7401-eng-115	Manhattan District Contract Files, Oak Ridge, Tennessee

<u>No.</u>	<u>Description</u>	<u>Location</u>
25 ✓	Minutes of Meeting, Recreation & Welfare Association	Manhattan District Files, Oak Ridge Tennessee
26 ✓	Grant of Authority for Oak Ridge Recreation & Welfare Association, dated 1 January 1944	Manhattan District Files, Oak Ridge Tennessee
27 ✓	Organization Charts, Oak Ridge Recreation & Welfare Association	Recreation & Welfare Association Files, Oak Ridge, Tennessee
28 ✓	Financial Statements, Oak Ridge Recreation & Welfare Association	Recreation & Welfare Association Files, Oak Ridge, Tennessee
29 ✓	Oak Ridge Recreation & Welfare Association Budget, 1945	Recreation & Welfare Association Files, Oak Ridge, Tennessee
30 ✓	Completion Report, Portion of Townsite Planning of Oak Ridge, Tennessee, Covered by Contract No. W-7401-eng-29, Skidmore, Owings & Merrill, Architect-Engineer, Oak Ridge, Tennessee, 9 September 1944	Manhattan District Classified Files, Oak Ridge, Tennessee
31 ✓	Preliminary Historical Report, J. O. 7201, Clinton Engineer Works, Townsite and Central Facilities, Stone & Webster Engineering Corporation, dated 12 June 1945	Classified Files, Stone & Webster Engineering Corporation, Oak Ridge, Tennessee
31a	Contract No. W-7418-eng-100, with John A. Johnson Contracting Corporation	Manhattan District Contract Files, Oak Ridge, Tennessee
31c	Car Records, Louisville & Nashville Railroad Company	Files, Louisville & Nashville Railroad Company, Oak Ridge, Tennessee

<u>No.</u>	<u>Description</u>	<u>Location</u>
32 ✓	Contract No. W-7418-eng-7, with John A. Johnson Con- tracting Corporation	Manhattan District Contract Files, Oak Ridge, Tennessee
32a ✓	Contract No. W-28-094-eng-41, with Louisville & Nashville Railroad Company	Manhattan District Contract Files, Oak Ridge, Tennessee
33 ✓	Contract No. W-7415-eng-1, with O'Driscoll & Grove, Inc.	Manhattan District Contract Files, Oak Ridge, Tennessee
34 ✓	Contract No. W-7415-eng-6, with Clinton Home Builders	Manhattan District Contract Files, Oak Ridge, Tennessee
35 ✓	Contract No. W-7415-eng-10, with O'Driscoll & Grove, Inc.	Manhattan District Contract Files, Oak Ridge, Tennessee
36 ✓	Contract No. W-7421-eng-4, with Coupe Construction Company	Manhattan District Contract Files, Oak Ridge, Tennessee
37 ✓	Contract No. W-7415-eng-48, with Foster & Creighton Company	Manhattan District Contract Files, Oak Ridge, Tennessee
38 ✓	Contract No. W-7401-eng-72, with Schult Trailers, Inc.	Manhattan District Contract Files, Oak Ridge, Tennessee
39 ✓	Contract No. W-7401-eng-138, with Schult Trailers, Inc.	Manhattan District Contract Files, Oak Ridge, Tennessee
40 ✓	Contract No. W-7401-eng-71, with National Homes, Inc.	Manhattan District Contract Files, Oak Ridge, Tennessee

<u>No.</u>	<u>Description</u>	<u>Location</u>
41 ✓	Contract No. W-7401-eng-128, with National Homes, Inc.	Manhattan District Contract Files, Oak Ridge, Tennessee
42 ✓	Contract No. W-7401-eng-143, with National Homes, Inc.	Manhattan District Contract Files, Oak Ridge, Tennessee
43 ✓	Contract No. W-7401-eng-203, with National Homes, Inc.	Manhattan District Contract Files, Oak Ridge, Tennessee
44 ✓	Contract No. W-7401-eng-144, with Gunnison Housing Corporation	Manhattan District Contract Files, Oak Ridge, Tennessee
44a ✓	Contract No. W-7401-eng-145, with Alma Trailers, Inc.	Manhattan District Contract Files, Oak Ridge, Tennessee
45 ✓	Contract No. W-7401-eng-139, with the E. L. Bruce Company	Manhattan District Contract Files Oak Ridge, Tennessee
46 ✓	Contract No. W-7418-eng-71, with John A. Johnson Con- tracting Corporation	Manhattan District Contract Files, Oak Ridge, Tennessee
46a ✓	Contract No. W-14-108-eng-55, with John A. Johnson Con- tracting Corporation	Manhattan District Contract Files, Oak Ridge, Tennessee
46b ✓	Contract No. W-14-108-eng-57, with John A. Johnson Con- tracting Corporation	Manhattan District Contract Files, Oak Ridge, Tennessee
47 ✓	Contract No. W-7418-eng-68, with John A. Johnson Con- tracting Corporation	Manhattan District Contract Files, Oak Ridge, Tennessee

<u>No.</u>	<u>Description</u>	<u>Location</u>
48 ✓	Contract No. W-7415-eng-50, with Foster & Creighton Company	Manhattan District Contract Files, Oak Ridge, Tennessee
49 ✓	Contract No. W-7418-eng-72, with John A. Johnson Con- tracting Corporation	Manhattan District Contract Files, Oak Ridge, Tennessee
49a ✓	Contract No. W-222-075-eng-49, with John A. Johnson Con- tracting Corporation	Manhattan District Contract Files, Oak Ridge, Tennessee
50 ✓	Progress Reports, Townsite and Central Facilities, Stone & Webster Engineering Corpo- ration	Manhattan District Contract Files, Oak Ridge, Tennessee
51 ✓	Contract No. W-7415-eng-12 and Contract No. W-7415-eng-8 with Foster & Creighton Company	Manhattan District Contract Files, Oak Ridge, Tennessee
52	Memorandum, District Engineer to Major General L. R. Groves, "Additional Dormitories"	Manhattan District Classified Files, Oak Ridge, Tennessee
53 ✓	Contract No. W-7415-eng-7 with Foster & Creighton Company	Manhattan District Contract Files, Oak Ridge, Tennessee
54 ✓	Contract No. W-14-108-eng-70, with John A. Johnson Con- tracting Corporation	Manhattan District Contract Files, Oak Ridge, Tennessee
55 ✓	Contract No. W-7418-eng-9, with A. Farnell Blair	Manhattan District Contract Files, Oak Ridge, Tennessee
56	Contract No. W-7418-eng-10, with A. Farnell Blair	Manhattan District Contract Files, Oak Ridge, Tennessee

<u>No.</u>	<u>Description</u>	<u>Location</u>
57	Contract No. W-7418-eng-65, with A. Farnell Blair	Manhattan District Contract Files, Oak Ridge, Tennessee
58	Contract No. W-7415-eng-51, with Clinton Home Builders	Manhattan District Contract Files, Oak Ridge, Tennessee
59	Memorandum, Ryan to Hodgson, "Housing Rental Rates" dated 2 September 1944	Manhattan District Files, Oak Ridge, Tennessee
60	Letter, Blair to Stone & Webster, dated 1 June 1943	Manhattan District Files, No. CEW 620, Oak Ridge, Tennessee
61	Memorandum, L. H. Jackson to the Files, subject: "Operation of Trailer Camp", dated 24 June 1944.	Manhattan District Files, No. CEW 620, Oak Ridge, Tennessee
62	Letter, Hodgson to Hernandez, subject: "Assignment Policy", dated 17 July 1944	Manhattan District Files, Oak Ridge, Tennessee
63	Letter, Cost Section, Adminis- trative Division, Manhattan Dis- trict, subject: "Construction Costs of Water Distribution and Sewers-Townsite Area-By those Contracts not under Stone & Webster", dated 14 November 1943, with 1 incl.	Files, Control De- partment, Facili- ties and Service Division, Man- hattan District, Oak Ridge, Tennessee
64	Letter, Major General L. R. Groves to Secretary of War, subject: "Housing Rental Rates".	Manhattan District Classified Files, Oak Ridge, Tennessee
65	Letter, District Engineer to Major General L. R. Groves, subject: "Additional Facili- ties".	Manhattan District Files, Oak Ridge, Tennessee

<u>No.</u>	<u>Description</u>	<u>Location</u>
66	Memorandum, Blair to O'Weara, subject: "Town Planning", dated 26 January 1943	Manhattan District Files, Oak Ridge, Tennessee
67	Letter, O'Weara to Roane-Anderson Company, subject: "Concession Operations", dated 25 January 1944	Manhattan District Files, Oak Ridge, Tennessee
68	Concession Report, Roane-Anderson Company, dated 30 April 1946	Files, Concessions and Subcontracts Section, Facilities and Service Division, Manhattan District, Oak Ridge, Tennessee
68a	Deleted.	
68b	Classified Concessions Granted to Date, Roane-Anderson Company, dated 27 May 1946	Files, Concessions and Subcontracts Section, Facilities and Service Division, Manhattan District, Oak Ridge, Tennessee
69	Minutes of Meetings, Central Facilities Advisory Committee	Manhattan District Files, Oak Ridge, Tennessee
69a	File: "Western Union".	Files, Concessions and Subcontracts Section, Facilities and Service Division, Manhattan District, Oak Ridge, Tennessee
70	Deleted.	
70a	License Agreements, No. RA 43, Roane-Anderson Company with Western Union Telegraph Company	Manhattan District Files, Oak Ridge, Tennessee
70b	War Department Circular No. 40, dated 4 February 1943; War Department Circular No. 19, dated 24 August 1943	

<u>No.</u>	<u>Description</u>	<u>Location</u>
70c ✓	File: "Hamilton National Bank"	Files, Concessions and Subcontracts Section, Facilities and Service Division, Manhattan District, Oak Ridge, Tennessee
71 ✓	Subcontract No. RA 1, Roane-Anderson Company, with Western Union Telegraph Company	Manhattan District Contract Files, Oak Ridge, Tennessee
72	Letter, No. D-41, Manhattan District, New York, N. Y., subject: "Organization-Manhattan District", dated 10 April 1943, with 1 incl (Orgn. Chart)	Files, Administrative Department, Facilities and Service Division, Manhattan District, Oak Ridge, Tennessee
73	<i>Deleted</i>	
74 ✓	Letter from the Attorney General, State of Tennessee	Manhattan District Files, Oak Ridge, Tennessee
75	Public Law 849, 76th Congress, 3rd Session	
76	Letter, Dr. A. H. Blankenship to Captain Hill, "Operating Data, Oak Ridge Schools"	Manhattan District Files, Oak Ridge, Tennessee
77	Letter, A. C. Klein to District Engineer, subject: "Power Supply," dated 21 October 1942	Manhattan District Files, Oak Ridge, Tennessee
78	"Estimated Power Requirements" (chart), Stone & Webster Engineering Corporation, dated 17 September 1943	Manhattan District Files, Oak Ridge, Tennessee
79 ✓	Contract No. W-14-108-eng-52, with John A. Johnson Contracting Corporation	Manhattan District Contract Files, Oak Ridge, Tennessee

~~SECRET~~

<u>No.</u>	<u>Description</u>	<u>Location</u>
80	Subcontract No. 5-G-2705, Stone & Webster Engineering Corporation, with Tennessee Valley Authority	Manhattan District Contract Files, Oak Ridge, Tennessee
81 ✓	Contract No. W-14-108-eng-64, with John A. Johnson Contracting Corporation	Manhattan District Contract Files, Oak Ridge, Tennessee
82 ✓	Contract No. W-7401-eng-13, with Stone & Webster Engineering Corporation	Manhattan District Contract Files, Oak Ridge, Tennessee
83	Subcontract No. 47-G-6232, Stone & Webster Engineering Corporation, with Tennessee Valley Authority	Manhattan District Contract Files, Oak Ridge, Tennessee
84	Contract No. W-17-028-eng-51, with Tennessee Valley Authority	Manhattan District Contract Files, Oak Ridge, Tennessee
85	Contract No. W-7418-eng-74, with Tennessee Valley Authority	Manhattan District Contract Files, Oak Ridge, Tennessee
86	Contract No. W-44-153-eng-36, with Tennessee Valley Authority	Manhattan District Contract Files, Oak Ridge, Tennessee
87	Contract No. W-7418-eng-73, with Tennessee Valley Authority	Manhattan District Contract Files, Oak Ridge, Tennessee
88	Subcontract No. 36-G-9802, with Stone & Webster Engineering Corporation, with Tennessee Valley Authority	Manhattan District Contract Files, Oak Ridge, Tennessee

<u>No.</u>	<u>Description</u>	<u>Location</u>
89 ✓	Subcontract No. RA 15, Roane-Anderson Company with Eugene L. DeHeigh, dated 29 September 1945	Files, Concessions Subcontracts Section, Administrative Department, Facilities and Service Division, Manhattan District, Oak Ridge, Tennessee
90	Contract No. W-7415-eng-69, with Tennessee Valley Authority	Manhattan District Contract Files, Oak Ridge, Tennessee
91	Letter, Colonel Stowers to District Engineer, dated 19 August 1944	Classified Files, Manhattan District, MD675, Case No. 14632
92	Contract No. W-7418-eng-163, with Tennessee Valley Authority	Manhattan District Contract Files, Oak Ridge, Tennessee
93	Subproject No. 1, Stone & Webster Engineering Corporation	Manhattan District Files, Oak Ridge, Tennessee
94	Memorandum, Stowers to Kelley, 24 March 1944 on Power Requirements	Manhattan District Files, No. M. D. 463, Oak Ridge, Tennessee
95	Contract No. W-7418-eng-6, with Tennessee Valley Authority	Manhattan District Contract Files, Oak Ridge, Tennessee
96	Contract No. W-8418-eng-5, with Tennessee Valley Authority	Manhattan District Contract Files, Oak Ridge, Tennessee
97 ✓	Preliminary Report Covering Effect of Treated Sewage on Water Supply, dated 30 April 1943	Manhattan District Files, No. 573, Oak Ridge, Tennessee

<u>No.</u>	<u>Description</u>	<u>Location</u>
98	Memorandum on Water Supply and Sewerage Facilities, 17 April 1943	Manhattan District Files, No. M. D. 197, Oak Ridge, Tennessee
99	Subproject No. 23, Stone & Webster Engineering Corporation	Manhattan District Files, Oak Ridge, Tennessee
100	Contract No. W-7415-eng-3, with D. W. Winkelman Company	Manhattan District Contract Files, Oak Ridge, Tennessee
101	Contract No. W-7423-eng-2, with D. W. Winkelman Company	Manhattan District Contract Files, Oak Ridge, Tennessee
102	Laboratory Files, Central Water Supply System	Files, Department of Public Works, Facilities and Service Division, Manhattan District, Oak Ridge, Tennessee
103	Subproject No. 41, Stone & Webster Engineering Corporation	Manhattan District Files, Oak Ridge, Tennessee
104	Letter from A. O. Klein, subject: "Location of Sewage Treatment Plants", January 1943	Manhattan District File 671.2, Oak Ridge, Tennessee
105	Subproject No. 56, Stone & Webster Engineering Corporation	Manhattan District Files, Oak Ridge, Tennessee
106	Contract No. W-7415-eng-4, with Sullivan, Long & Hagerty	Manhattan District Contract Files, Oak Ridge, Tennessee
107	Contract No. W-7415-eng-19, with Sullivan, Long & Hagerty	Manhattan District Contract Files, Oak Ridge, Tennessee

<u>No.</u>	<u>Description</u>	<u>Location</u>
108	Contract No. W-7418-eng-66, with Ralph Rogers Company	Manhattan District Contract Files, Oak Ridge, Tennessee
109	Contract No. W-7409-eng-47, with Wright & Lopez	Manhattan District Contract Files, Oak Ridge, Tennessee
110	Contract No. W-7415-eng-15, with Sullivan, Long & Nagarty	Manhattan District Files, Oak Ridge, Tennessee
111	Minutes of Access Road Meeting, 3 November 1943	Manhattan District Files, Oak Ridge, Tennessee
112	Access Road File (Manhattan District)	Manhattan District Files, Oak Ridge, Tennessee
113	Bridge File	Files, Legal Section, Administrative Division, Manhattan District, Oak Ridge, Tennessee
114	Letter, W. H. Lockney, Louisville & Nashville Railroad Company, to Stone & Webster Engineering Corporation	Manhattan District Files, No. 531.7 (CBW), Oak Ridge, Tennessee
115	Transportation Survey at Clinton Engineer Works, conducted by Fourth Zone Transportation Office, June 1944	Manhattan District Files, Oak Ridge, Tennessee
116	Special Order, ODT, R-5	Manhattan District Files, No. 531.7 (CBW), Oak Ridge, Tennessee
117	Letter, J. M. Roberts, Office of Defense Transportation, to Major Buckley, dated 26 May 1944 (Referring to ODT Approval Order 35-537-302-A)	Manhattan District Files, Oak Ridge, Tennessee

<u>No.</u>	<u>Description</u>	<u>Location</u>
118	Letter, J. M. Roberts, Office of Defense Transportation, to Major Buckley, dated 19 June 1944 (Referring to Supplement No. 1 to ODT Approval Order 35-537-302-A)	Manhattan District Files, Oak Ridge, Tennessee
119	Letter, J. M. Roberts, Office of Defense Transportation, to Major Buckley, dated 14 July 1944 (Referring to Supplement No. 2 to ODT Approval Order 35-537-302-A)	Manhattan District Files, Oak Ridge, Tennessee
120	Contract No. W-14-108-eng-53, with American Industrial Transit	Manhattan District Files, Oak Ridge, Tennessee
121	Correspondence with Bus Operators	Manhattan District Files, "Bus Transportation", Oak Ridge, Tennessee
122	Monthly Statistical Report of Operations, Prepared by American Industrial Transit	Manhattan District Files, Oak Ridge, Tennessee
122a	<i>Deleted</i>	
122b	Statistical Report of Operations, American Industrial Transit, Cumulative for 1946	Files, Bus Transportation Section, Department of Public Works, Facilities and Service Division, Manhattan District, No. 127.2, Oak Ridge, Tennessee
123	Letter to CBB Bus Authority, subjects "School Service", dated 12 September 1944	Manhattan District Files, Oak Ridge, Tennessee
124	Notes on Fare Conference, 13 July 1944	Manhattan District Files, Oak Ridge, Tennessee

<u>No.</u>	<u>Description</u>	<u>Location</u>
125	Letter, Lieutenant Colonel Hodgson, to operating contractors regarding fare structure, dated 13 August 1944	Manhattan District Files, Oak Ridge, Tennessee
126	Monthly American Industrial Transit Financial Statement	Manhattan District Files, Oak Ridge, Tennessee
127	Minutes of Transportation Board Meeting, 17 December 1943	Manhattan District Files, Oak Ridge, Tennessee
128	Letter from A. H. Gossard to R. L. Montgomery, subject: "Termination of Contract"	Manhattan District Files, Oak Ridge, Tennessee
129	Bus Operation Subcontracts under Contract No. W-7401-eng-115	Manhattan District Contract Files, Oak Ridge, Tennessee
130	Contract No. W-7409-eng-45, with Christopher & Company	Manhattan District Contract Files, Oak Ridge, Tennessee
131	Letter, Major Kelley to J. C. White, Tennessee Eastman Corporation, November 1943, subject: "Subsidized Bus Transportation"	Manhattan District Files, Oak Ridge, Tennessee
132	Subcontract, Under Contract No. W-7401-eng-13, Stone & Webster Engineering Corporation with Louisville & Nashville Railroad Company	Manhattan District Contract Files, Oak Ridge, Tennessee
133	Letter, Lieutenant Colonel Hodgson to Mr. F. Creedon, Stone & Webster Engineering Corporation, dated 12 July 1944	Manhattan District Files, Oak Ridge, Tennessee
134	Memorandum, Major Swanson to Lieutenant Colonel Hodgson, subject: "Proposed Rail Service between Oak Ridge and K-25"	Manhattan District Files, Oak Ridge, Tennessee

<u>No.</u>	<u>Description</u>	<u>Location</u>
135	Central Facilities Traffic Surveys	Manhattan District Files, Oak Ridge, Tennessee
136	Memorandum to Lieutenant Colonel Hodgson outlining results of car occupancy survey, October 1944	Manhattan District Files, Oak Ridge, Tennessee
137	Contract No. W-7409-eng-48, with Christopher & Company	Manhattan District Contract Files, Oak Ridge, Tennessee
138	Contract No. W-7423-eng-1, with Drainage Contractors, Inc.	Manhattan District Contract Files, Oak Ridge, Tennessee
139	"Report on Proposed Site for Plant, Eastern Tennessee", Stone & Webster Engineering Corporation, transmitted with Letter, E. LaCrosse to Colonel J. C. Marshall, subject: "Proposed Site for Plant, Eastern Tennessee", dated 14 July 1942	Manhattan District Classified Files, No. M. D. 680.1, Oak Ridge, Tennessee
140	Letter of Intent, OSRD by Irvin Stuart to Stone & Webster Engineering Corporation, G. O. Muhlfield, for preliminary engineering and design of a separation plant, dated 13 March 1942	Manhattan District Classified Files, No. M. D. 680.1, Oak Ridge, Tennessee
141	Memorandum, "Tentative Selection of a Plant Site in T.V.A. Area", by M. J. Whitson, Stone & Webster Engineering Corporation; Z. M. Deutsch, and T. V. Moore, Standard Oil Development Corporation, dated 27 April 1942	Manhattan District Classified Files, No. M. D. 680.1, Oak Ridge, Tennessee
142	Memorandum, Dr. Arthur H. Compton to Vannevar Bush, subject: "Power Project", with Report No. O3-119, subject: "Memorandum on the Factors Affecting the Choice of the Plant Site", dated 13 June 1942	Manhattan District Classified Files, No. M. D. 680.1, Oak Ridge, Tennessee

~~SECRET~~

<u>No.</u>	<u>Description</u>	<u>Location</u>
143	Memorandum, Stone & Webster Engineering Corporation subjects "Second Visit to T.V.A. Looking for Available War Plant Sites", dated 13 July 1942	Manhattan District Classified Files, No. M. D. 680.1, Oak Ridge, Tennessee
144	Memorandum, Stone & Webster Engineering Corporation, subjects "Meeting in Chicago, July 6, 1942", dated 6 July 1942	Manhattan District Classified Files, No. M. D. 680.1, Oak Ridge, Tennessee
145	Report, subjects "Gross Appraisal for Proposed Kingston Army Camp for Demolition Range, Kingston, Tennessee," dated 3 August 1942, and Supplement to Report, dated 26 September 1942, both by Lieutenant Colonel M. J. O'Byrne, Division Real Estate Director, Ohio River Division, U. S. Engineers	Manhattan District Classified Files, No. M. D. 601.1-CEW, Oak Ridge, Tennessee
146	Letter, Lieutenant Colonel George to Stone & Webster Engineering Corporation, regarding hutment rentals and subsidy payments, dated 20 August 1943	Manhattan District Files, Oak Ridge, Tennessee
147	Letter, Stone & Webster Engineering Corporation to District Engineer, dated 8 January 1944, concerning rental rates and subsidies on hutments	Manhattan District Files, Oak Ridge, Tennessee
148	Subcontract No. RA-148, Roane-Anderson Company with Gibson Service Management Company, dated 30 June 1945; Subcontract No. RA-132, Roane-Anderson Company with Gibson Service Management Company, dated 4 June 1945	Manhattan District Contract Files, Oak Ridge, Tennessee
149	Public Acts, 1933, State of Tennessee, Chapter 119	
150	War Department Circular No. 80, dated 20 March 1943	

<u>No.</u>	<u>Description</u>	<u>Location</u>
151	Public Law No. 358, 78th Congress	
152	General Guard Order No. 46, dated 14 April 1944	Files, Department of Public Safety, Manhattan District, Oak Ridge, Tennessee
153	General Guard Order No. 12, dated 15 March 1945	Files, Department of Public Safety, Manhattan District, Oak Ridge, Tennessee
154	Letter, District Intelligence Officer, to All Concerned, subject: "Prohibited Area-CEW", dated 26 July 1944	Classified Files, Department of Public Safety, Manhattan District, Oak Ridge, Tennessee
155	General Guard Order No. 34, 16 June 1945	Files, Department of Public Safety, Manhattan District, Oak Ridge, Tennessee
156	General Guard Order No. 39, dated 11 July 1945	Files, Department of Public Safety, Manhattan District, Oak Ridge, Tennessee
157	Fire Prevention Rules and Regulations for Clinton Engineer Works	Classified Files, Department of Public Safety, Manhattan District, Oak Ridge, Tennessee
158	Area Regulations, Issued by the District Engineer 1 November 1945	Classified Files, Department of Public Safety, Manhattan District, Oak Ridge, Tennessee

<u>No.</u>	<u>Description</u>	<u>Location</u>
159 ✓	Fire Prevention Alarm Report, dated 17 February 1943	Classified Files, Department of Public Safety, Manhattan District, Oak Ridge, Tennessee
160	Letter, G. M. Johnson, to District Intelligence Officer, dated 28 May 1943	Classified Files, Department of Public Safety, Manhattan District, Oak Ridge, Tennessee
161 ✓	Fire Department Alarm Report, dated 11 October 1944	Fire Department Classified Files, Oak Ridge, Tennessee
162 ✓	Fire Department Alarm Report, dated 21 January 1945	Fire Department Classified Files, Oak Ridge, Tennessee
163 ✓	Fire Department Answered all Fire Alarm Report for 1944	Fire Department Classified Files, Oak Ridge, Tennessee
164 ✓	Fire Department Alarm Reports	Fire Department Classified Files, Oak Ridge, Tennessee
165 ✓	Summary of Fire Alarms, Oak Ridge Fire Department, December 1944 - April 1946	Files, Fire Marshal's Office, Oak Ridge, Tennessee
166	National Fire Protection Association Quarterly, Vol. 39, No. 4, pt. 1, April 1946	
167	Contract No. W-7418-eng-18, with D. W. Winkelman Company	Manhattan District Contract Files, Oak Ridge, Tennessee

<u>No.</u>	<u>Description</u>	<u>Location</u>
168	Contract No. W-7418-eng-67, with A. Farnell Blair	Manhattan District Contract Files, Oak Ridge, Tennessee
169	Contract No. W-7415-eng-104, with D. W. Winkelman Company	Manhattan District Contract Files, Oak Ridge, Tennessee
170	Contract No. W-7405-eng-301, with Birmingham Construction Company	Manhattan District Contract Files, Oak Ridge, Tennessee
171	Contract No. W-14-108-eng-63, with John A. Johnson Contract- ing Corporation	Manhattan District Contract Files, Oak Ridge, Tennessee
172	Contract No. W-14-108-eng-67, with L. C. Powers Construction Company	Manhattan District Contract Files, Oak Ridge, Tennessee
173	Contract No. W-22-075-eng-62, with Christopher & Company	Manhattan District Contract Files, Oak Ridge, Tennessee
174	Contract No. W-7423-eng-3, with Drainage Contractors, Inc.	Manhattan District Contract Files, Oak Ridge, Tennessee
175	Concession Agreement No. RA 99-Y, Roane-Anderson Company with Tennessee Sportservice, Inc., dated 4 May 1945	Files, Concessions and Subcontracts Section, Adminis- trative Depart- ment, Facilities & Service Divi- sion, Manhattan District, Oak Ridge, Tennessee
176	Concession Agreement No. RA 152, Roane-Anderson Company with Can- teen Food Service, dated 16 July 1945	Files, Administra- tive Department, Facilities & Serv- ice Division, Oak Ridge, Tennessee

<u>No.</u>	<u>Description</u>	<u>Location</u>
177	Concession Agreement No. RA 164, Roane-Anderson Company with Canteen Food Service, Inc., dated 13 August 1945	Files, Concessions and Subcontracts Section, Administrative Department, Facilities & Service Division, Manhattan District, Oak Ridge, Tennessee
178	Contract No. W-22-075-eng-115, with B. R. Hinson Construction Company	Manhattan District Contract Files, Oak Ridge, Tennessee
179	Contract No. W-22-075-eng-111, with Christopher & Company	Manhattan District Contract Files, Oak Ridge, Tennessee
180	Concession Agreement No. RA 166, Roane-Anderson Company with Anthony Cappiello and Tomay and H. G. Tucker, dated 27 August 1945	Files, Concessions and Subcontracts Section, Administrative Department, Facilities & Service Division, Manhattan District, Oak Ridge, Tennessee
181	Public Law 779, 77th Congress, dated 1 December 1942	
182	Contract No. W-28-094-eng-94, with Southern Bell Telephone and Telegraph Company	Manhattan District Contract Files, Oak Ridge, Tennessee
183	Files, Stone & Webster Engineering Corporation, Oak Ridge, Tennessee	
184	Receiving Report No. 7687, Roane-Anderson Company from J. A. Jones Construction Company, dated 18 June 1945	Files, Cost Section, Administrative Division, Manhattan District, Oak Ridge, Tennessee

<u>No.</u>	<u>Description</u>	<u>Location</u>
185 ✓	See Map, App. B4, Coordinates E54,000, N 44,000; E61,900, N 44,600; E59,000, N 41,000; E56,800, N 34,600; E67,500, N 41,000; E70,000, N 43,000; E81,000, N 41,700; E65,000, N 43,400	
186 ✓	Concessions Agreement No. 207A, Roane-Anderson Company with Area Laundry & Dry Cleaning Company	Files, Concessions Division, Roane- Anderson Company, Oak Ridge, Tennessee
187	Special Order 10, Manhattan Dis- trict, Clinton Engineer Works, dated 30 September 1943	Files, Administra- tive Department, Facilities and Service Division, Manhattan Dis- trict, Oak Ridge, Tennessee
188 ✓	Letter, Office of the District Engineer, subject: "Grant of Authority for Oak Ridge Health Association", dated 13 October 1944	Manhattan District Files, Oak Ridge, Tennessee
189	Subcontract No. 5, Roane-Anderson with Tri-State Homes, Inc.	Files, Concessions and Subcontracts Section. Facili- ties & Service Division, Man- hattan District, Oak Ridge, Tennessee
190 ✓	Subcontract No. 3, Roane-Anderson Company with Leatherman and Alley	Files, Concessions and Subcontracts Section, Facili- ties and Service Division, Man- hattan District, Oak Ridge, Tennessee

<u>No.</u>	<u>Description</u>	<u>Location</u>
191 ✓	Subcontract No. 6, Roane-Anderson Company with Galbreath-Moore Company	Files, Concessions and Subcontracts Section, Facilities and Service Division, Manhattan District, Oak Ridge, Tennessee
192 ✓	Subcontract No. 21, Roane-Anderson Company with Oak Ridge Health Association	Files, Purchasing Department, Roane-Anderson Company, Oak Ridge, Tennessee
193 ✓	Narrative Cost Report, Clinton Engineer Works, Prepared for the United States Engineer Department, Manhattan District, by Stone & Webster Engineering Corporation, Architect-Engineer-Management. Boston, Massachusetts, Contract W-7401-eng-13, 4 Vols, Oak Ridge, Tennessee, 1946	Manhattan District Classified Files, Oak Ridge, Tennessee
194 ✓	American Industrial Transit Monthly Cost Analyses	Office, American Industrial Transit, Oak Ridge, Tennessee
195 ✓	Public Proclamation No. 8, Headquarters Eastern Defense Command; Public Proclamation No. 1, Headquarters Seventh Army	
196 ✓	Cost Records, Roane-Anderson Company	Files, Roane-Anderson Company, Oak Ridge, Tennessee
197 ✓	Letter, Roane-Anderson Company, to Oak Ridge Health Association, subject: "Termination of Contract", dated 11 April 1946	Files, Roane-Anderson Company, Oak Ridge, Tennessee

<u>No.</u>	<u>Description</u>	<u>Location</u>
198	Communications Service Accounts	Files, Communications Department, Facilities and Service Division, Manhattan District, Oak Ridge, Tennessee
199 ✓	Bell System Line and Station Report, dated 31 July 1945	Files, Communications Department, Facilities and Service Division, Manhattan District, Oak Ridge, Tennessee
200 ✓	Subcontract No. 21 (1946), Roane-Anderson Company with Oak Ridge Housing Company	Files, Concessions and Subcontract Section, Administrative Department, Facilities and Service Division, Manhattan District, Oak Ridge, Tennessee
201 ✓	Subcontract No. 6A (1946), Roane-Anderson Company with Oalbreath-Moore Company	Files, Concessions and Subcontract Section, Administrative Department, Facilities and Service Division, Manhattan District, Oak Ridge, Tennessee
203 ✓	United States Code Annotated, Title 50 (War)	
204 ✓	Executive Orders, No. 8972, dated 12 December 1941	
205 ✓	Public Proclamation No. 2, Headquarters Southern Defense Command, dated 25 March 1943	

~~SECRET~~

<u>No.</u>	<u>Description</u>	<u>Location</u>
206 ✓	Completion Report, Portion of Townsite Planning of Oak Ridge, Tennessee, Covered by Contract No. W-17-028-eng-53, Skidmore, Owings and Merrill, Architect-Engineer, Oak Ridge, Tennessee, 15 June 1946	Manhattan District Classified Files, Oak Ridge, Tennessee
207 ✓	Files "Oak Ridge Laundry Operation"	Files, Concessions and Subcontracts Section, Adminis- trative Department, Facilities and Service Division, Manhattan District, Oak Ridge, Tennessee
208	Public Law No. 703, 76th Congress 2 July 1940; Public Law No. 354, 77th Congress, 5 June 1942; Executive Order 9001, 27 December 1941; Public Law No. 580, 5 June 1942	
209	Subcontract No. XPO-1057, E. I. DuPont de Nemours Company, with Tennessee Valley Authority	Manhattan District Contract Files, Oak Ridge, Tennessee
210	Contract No. W-7412-eng-23, with E. I. DuPont de Nemours & Company	Manhattan District Contract Files, Oak Ridge, Tennessee
211	Subcontract No. 47-0-6232, Stone & Webster Engineering Corporation, with Tennessee Valley Authority	Manhattan District Contract Files, Oak Ridge, Tennessee
212	Contract No. W-44-153-eng-39, with Tennessee Valley Authority	Manhattan District Contract Files, Oak Ridge, Tennessee
213	Contract No. W-7405-eng-101, and Modifications 1 to 8, with A. S. Schulman Electrical Company	Manhattan District Contract Files, Oak Ridge, Tennessee

<u>No.</u>	<u>Description</u>	<u>Location</u>
213a	Contract No. W-31-109-eng-32, with Watson-Flagg Engineering Company	Manhattan District Contract Files, Oak Ridge, Tennessee
214	Letter, subject: "Construction Items Requiring Completion Subsequent 28 February 1946 to Elza No. 1 and No. 2 Substations."	Files, Electric Power Division, Manhattan District, Oak Ridge, Tennessee
215	Contract No. W-14-108-eng-49, with Stone & Webster Engineering Corporation	Manhattan District Contract Files, Oak Ridge, Tennessee
216	Contract No. W-7405-eng-23, with Kelllex Corporation	Manhattan District Contract Files, Oak Ridge, Tennessee
217	Contract No. W-7418-eng-6, with Tennessee Valley Authority	Manhattan District Contract Files, Oak Ridge, Tennessee
217a	Letter, Manhattan District, to A. S. Schulman Electrical Company, dated 24 June 1946	Manhattan District Contract Files, Oak Ridge, Tennessee
218 ✓	Contract No. W-7401-eng-115, Modification No. 7, with Roane-Anderson Company	Manhattan District Contract Files, Oak Ridge, Tennessee
219 ✓	Contract No. W-22-075-eng-71, with Wilson and Rogers Company; Contract No. W-22-075-eng-85, with Wilson and Rogers Company	Manhattan District Contract Files, Oak Ridge, Tennessee
220 ✓	Contract No. W-14-108-eng-71, with John A. Johnson Contracting Corporation	Manhattan District Contract Files, Oak Ridge, Tennessee
221 ✓	Contract No. W-7418-eng-1, with Harrison Construction Company	Manhattan District Contract Files, Oak Ridge, Tennessee

~~SECRET~~

<u>No.</u>	<u>Description</u>	<u>Location</u>
222	Field Order, Subproject No. 50, J. A. Jones Construction Company Field Order Subprojects	Files, Department of Public Works (Engineering), Facilities and Service Division, Manhattan Dis- trict, Oak Ridge, Tennessee
223	Field Order, Subproject No. 046, J. A. Jones Construction Company Field Order Subprojects	Files, Department of Public Works (Engineering), Facilities and Service Division, Manhattan Dis- trict, Oak Ridge, Tennessee
224	Cost Records, Road Improvement, 1945 Recapitulation of Expendi- tures, Roane-Anderson Company	Files, Roads and Streets Depart- ment, Roane- Anderson Company, Oak Ridge, Tennessee
225	Project Costs, Buildings, 1945	Files, Department of Public Works (Engineering), Facilities and Service Division, Manhattan Dis- trict, No. 121.6, Oak Ridge, Tennessee
226	Cost Account, Contract W-7405-eng-101, A. S. Schulman Electrical Company	Files, Cost Account- ing Department, A. S. Schulman Electrical Company, Oak Ridge, Tennessee
227	Files "Power, Distribution of Costs"	Files, Electric Power Division, Plant Operations Group, Manhattan District, Oak Ridge, Tennessee

~~SECRET~~

<u>No.</u>	<u>Description</u>	<u>Location</u>
228	Smyth, H. D., "A General Account of the Development of Methods of Using Atomic Energy for Military Purposes Under the Auspices of the United States Government, 1940-1945," Washington, D. C., 1945	
229	General Guard Order No. 2, dated 24 September 1943	Files, Department of Public Safety, Facilities and Service Division, Manhattan District, Oak Ridge, Tennessee
230	General Guard Order No. 3, dated 20 November 1943	Files, Department of Public Safety, Facilities and Service Division, Manhattan District, Oak Ridge, Tennessee
231	General Guard Order No. 57, dated 17 May 1944	Files, Department of Public Safety, Facilities and Service Division, Manhattan District, Oak Ridge, Tennessee
232	General Guard Order No. 63B, dated 13 July 1944	Files, Department of Public Safety, Facilities and Service Division, Manhattan District, Oak Ridge, Tennessee
233	Organization Chart, Manhattan District, dated 28 August 1944	Files, Administrative Department, Facilities and Service Division, Manhattan District, Oak Ridge, Tennessee

<u>No.</u>	<u>Description</u>	<u>Location</u>
234	Organization Chart, Manhattan District, dated 10 November 1944	Files, Administrative Department, Facilities and Service Division, Manhattan District, Oak Ridge, Tennessee
235	Organization Chart, Manhattan District, dated 26 January 1945	Files, Administrative Department, Facilities and Service Division, Manhattan District, Oak Ridge, Tennessee
236	Organization Chart, Manhattan District, dated 21 June 1945	Files, Administrative Department, Facilities and Service Division, Manhattan District, Oak Ridge, Tennessee
237	Organization Chart, Manhattan District, Facilities and Service Division, CEW Security Branch, dated 31 October 1945	Files, Administrative Department, Facilities and Service Division, Manhattan District, Oak Ridge, Tennessee
238	Organization Chart, Manhattan District, Facilities and Service Division, dated 20 November 1945	Files, Administrative Department, Facilities and Service Division, Manhattan District, Oak Ridge, Tennessee
239	Organization Chart, Manhattan District, Facilities and Service Division, dated 30 November 1945	Files, Administrative Department, Facilities and Service Division, Manhattan District, Oak Ridge, Tennessee

~~SECRET~~

<u>No.</u>	<u>Description</u>	<u>Location</u>
240	Organization Chart, Manhattan District, dated 13 December 1945	Files, Administrative Department, Facilities and Service Division, Manhattan District, Oak Ridge, Tennessee
241	Organization Chart, Manhattan District, Facilities and Service Division, Public Security Branch, dated 1 February 1946	Files, Administrative Department, Facilities and Service Division, Manhattan District, Oak Ridge, Tennessee
242	Organization Chart, Manhattan District, Facilities and Service Division, Department of Public Safety, dated 22 March 1946	Files, Administrative Department, Facilities and Service Division, Manhattan District, Oak Ridge, Tennessee
243	Organization Chart, Manhattan District, Facilities and Service Division, Department of Public Safety, dated 9 May 1946	Files, Administrative Department, Facilities and Service Division, Manhattan District, Oak Ridge, Tennessee
244	Organization Chart, Manhattan District, Department of Public Safety, dated 1 July 1946	Files, Administrative Department, Facilities and Service Division, Manhattan District, Oak Ridge, Tennessee
245	Files "Budgets, Operating (Statements)"	Files, Control Department, Facilities and Service Division, Manhattan District, Oak Ridge, Tennessee

<u>No.</u>	<u>Description</u>	<u>Location</u>
246	Contract No. W-31-109-eng-79, with John A. Johnson Contracting Corporation	Manhattan District Contract Files, Oak Ridge, Tennessee
247	Letter, Roane-Anderson Company to U. S. Engineer Office, Manhattan District, dated 7 November 1946	Files, (No. Man. 600.15,R-A), Control Department, Facilities and Service Division, Manhattan District, Oak Ridge, Tennessee
248	Contract No. W-22-075-eng-51, with Harrison Construction Company	Manhattan District Contract Files, Oak Ridge, Tennessee
249	Contract No. W-17-028-eng-52, with Drainage Contractors, Inc.	Manhattan District Contract Files, Oak Ridge, Tennessee
250	Contract No. W-22-075-eng-48, with John F. Humphrey Company	Manhattan District Contract Files, Oak Ridge, Tennessee
251	Contract No. W-22-075-eng-56, with John F. Humphrey Company	Manhattan District Contract Files, Oak Ridge, Tennessee
252	Contract No. W-22-075-eng-61, with John F. Humphrey Company	Manhattan District Contract Files, Oak Ridge, Tennessee
253	Contract No. W-22-075-eng-105, with Christopher & Company	Manhattan District Contract Files, Oak Ridge, Tennessee
254	Contract No. W-22-075-eng-106, with Sullivan, Long & Hagerty	Manhattan District Contract Files, Oak Ridge, Tennessee

<u>No.</u>	<u>Description</u>	<u>Location</u>
255	Subproject C-15, Roane-Anderson Company with Harrison Construction Company	Files, Roane-Anderson Company, Oak Ridge, Tennessee
256	Organization Chart, Utilities and Maintenance Branch, dated 12 April 1945	Files, Administrative Department, Facilities and Service Division, Manhattan District, Oak Ridge, Tennessee
257	Subcontract No. 20 (1946), Roane-Anderson Company with Gibson Service Management Company	Files, Concessions and Subcontracts Section, Administrative Department, Facilities and Service Division, Oak Ridge, Tennessee
258	Subcontract No. 17, Roane-Anderson Company with Gibson Service Management Company	Files, Concessions and Subcontracts Section, Administrative Department, Facilities and Service Division, Oak Ridge, Tennessee
259	Subcontract No. 14 (1946), Roane-Anderson Company with Ridenour Management Company	Files, Concessions and Subcontracts Section, Administrative Department, Facilities and Service Division, Oak Ridge, Tennessee
260	Contract No. W-28-094-eng-46, with John A. Johnson Contracting Corporation	Manhattan District Contract Files, Oak Ridge, Tennessee
261	Memorandum, Control Department, Facilities and Service Division, Manhattan District, subject: "Apartments Converted from Dormitories", dated 2 October 1946	Files, Control Department, Facilities and Service Division, Manhattan District, Oak Ridge, Tennessee

<u>No.</u>	<u>Description</u>	<u>Location</u>
262	Contract No. W-31-109-eng-53, with John A. Johnson Contracting Corporation	Manhattan District Contract Files, Oak Ridge, Tennessee .
263	Memorandum, Control Department, Facilities and Service Division, Manhattan District, subject: "Apartments Converted from "S" Type Dormitory", dated 18 November 1946	Files, Control Department, Facilities and Service Division, Manhattan District, Oak Ridge, Tennessee
264	Files, Engineering and Operations Section, Department of Public Works, Facilities and Service Division, Manhattan District	Files, Engineering and Operations Section, Department of Public Works, Facilities and Service Division, Manhattan District, Oak Ridge, Tennessee
265	Letter, Cost Section, Administrative Division, Manhattan District, subject: "Construction Costs of Additional Housing", dated 30 October 1946, with 4 incls.	Files, Control Department, Administrative Department, Facilities and Service Division, Manhattan District, Oak Ridge, Tennessee
266	Card Index File, Farm House Occupancy, Housing Section, Administrative Department, Facilities and Service Division, Manhattan District	Housing Section, Administrative Department, Facilities and Service Division, Manhattan District, Oak Ridge, Tennessee
267	Letter, Roane-Anderson Company, subject: "Hutment and Barracks Costs", dated 4 December 1946	Files, Control Department, Facilities and Service Division, Manhattan District, Oak Ridge, Tennessee

~~SECRET~~

<u>No.</u>	<u>Description</u>	<u>Location</u>
268 ✓	Letter, Roane-Anderson Company subject: "Management Contract-Oak Ridge Housing Company", dated 17 September 1946	Files, Concessions and Subcontracts Section, Administrative Department, Facilities and Service Division, Manhattan District, Oak Ridge, Tennessee
269	File: "Tri-States Homes Company"	Files, Concessions and Subcontracts Section, Administrative Department, Facilities and Service Division, Manhattan District, Oak Ridge, Tennessee
270	Memorandum, Roane-Anderson Company, subject: "List of Roane-Anderson Purchase Orders of Items of Furniture and Furnishings for Initial Equipment of Dormitories, Etc., as Indicated.. ." (undated)	Files, Control Department, Facilities and Service Division, Manhattan District, Oak Ridge, Tennessee
271 ✓	Concessions Agreement No. RA 198, Roane-Anderson Company with Alexander Hotels, Inc., dated 11 January 1946	Files, Concessions and Subcontracts Section, Administrative Department, Facilities and Service Division, Manhattan District, Oak Ridge, Tennessee
272 ✓	Letter, Roane-Anderson Company, to Chief Inspector, Division of Hotel and Restaurant Inspection, Department of Conservation, State of Tennessee, dated 13 September 1946	Files, Concessions and Subcontracts Section, Administrative Department, Facilities and Service Division, Manhattan District, Oak Ridge, Tennessee

No.

Description

Location

273

Letter, Administrative Department, Facilities and Service Division, Manhattan District, subject: "Closing of Louisiana Cafeteria (Concession Agreement No. RA 164)", dated 9 August 1946

Files, Concessions and Subcontracts Section, Administrative Department, Facilities and Service Division, Manhattan District, Oak Ridge, Tennessee

274

Memorandum, Oak Ridge Hospital, subject: "Manhattan District History, Central Facilities, Medical Facilities and Services", dated 26 December 1946

Files, Department of Public Welfare, Facilities and Service Division, Manhattan District, Oak Ridge, Tennessee

275

Memorandum, Control Department, Facilities and Service Division, Manhattan District, subject: "Operation of First Aid Stations", dated 18 November 1946, with 2 incls.

Files, Control Department, Facilities and Service Division, Manhattan District, Oak Ridge, Tennessee

276

Letter, Roane-Anderson Company, dated 17 July 1946 (Referring to hospital construction costs)

Files, Control Department, Facilities and Service Division, Manhattan District, Oak Ridge, Tennessee

277

Files: "Oak Ridge Hospital (Operation)"

Files, Control Department, Facilities and Service Division, Manhattan District, Oak Ridge, Tennessee

278

Memorandum, Control Department, Facilities and Service Division, Manhattan District, subject: "Manhattan District History, Central Facilities, Water Supply System", dated 20 December 1946, with 3 incls., and 1st Memorandum Indorsement, Department of Public Works, Facilities and Service Division, dated 27 December 1946, with 4 incls.

Files, Control Department, Facilities and Service Division, Manhattan District, Oak Ridge, Tennessee X

<u>No.</u>	<u>Description</u>	<u>Location</u>
279	Memorandum, Control Department, Facilities and Service Division, Manhattan District, subjects: "Manhattan District History, Central Facilities, Sewerage System", dated 20 December 1946, with 3 incls., and 1st Memorandum Indorsement, Department of Public Works, Facilities and Service Division, dated 30 December 1946, with 4 incls.	Files, Control Department, Facilities and Service Division, Manhattan District, Oak Ridge, Tennessee
280	Memorandum, Department of Public Welfare, Facilities and Service Division, Manhattan District, subjects: "Manhattan District History, Social & Welfare Facilities and Service", dated 31 December 1946	Files, Control Department, Facilities and Service Division, Manhattan District, Oak Ridge, Tennessee
281	History of Recreation & Welfare Association, 21 July 1943 to 31 December 1946, prepared by Sweb T. Davis, Managing Director, dated 27 December 1946	Files, Department of Public Welfare, Facilities and Service Division, Manhattan District, Oak Ridge, Tennessee
282	Amended Grant of Authority for Oak Ridge Recreation & Welfare Association, dated 1 June 1945	Files, Department of Public Welfare, Facilities and Service Division, Manhattan District, Oak Ridge, Tennessee
283	Oak Ridge Welfare Service Report, 1 January 1946 to 30 September 1946	Files, Department of Public Welfare, Facilities and Service Division, Manhattan District, Oak Ridge, Tennessee
284	Grant of Authority for Oak Ridge Welfare Service, dated 1 July 1945, with Amendment, dated 1 July 1946	Files, Department of Public Welfare, Facilities and Service Division, Manhattan District, Oak Ridge, Tennessee

<u>No.</u>	<u>Description</u>	<u>Location</u>
285	Contract No. W-28-094-eng-77, with H. K. Williams Company	Manhattan District Contract Files, Oak Ridge, Tennessee
286	Memorandum, Control Department, Facilities and Service Division, Manhattan District, subject: "Manhattan District History, Central Facilities, Road System", dated 20 December 1946, with 2 incls., and 1st Memorandum Indorsement, Department of Public Works, Facilities and Service Division, dated 31 December 1946, with 4 incls.	Files, Control Department, Facilities and Service Division, Manhattan District, Oak Ridge, Tennessee
287	Road Improvement Cost Report	Files, Road and Streets Department, Roane-Anderson Company, Oak Ridge, Tennessee
288	Contracts Nos. W-31-109-eng-50, W-28-094-eng-62, and W-44-153-eng-47, with E. J. and W. L. Cobb, Inc.	Manhattan District Contract Files, Oak Ridge, Tennessee
289	Payment Vouchers	Files, Audit Section, Administrative Division, Manhattan District, Oak Ridge, Tennessee
290	Cost Ledgers	Files, Cost Section, Administrative Division, Manhattan District, Oak Ridge, Tennessee
291	Weekly Activity Report	Files, Roads and Streets Department, Roane-Anderson Company, Oak Ridge, Tennessee

<u>No.</u>	<u>Description</u>	<u>Location</u>
292	Special Job Cost Surveys	Files, Roads and Streets Department, Roane-Anderson Company, Oak Ridge, Tennessee
293	Memorandum, Control Department, Facilities and Service Division, Manhattan District, subject: "Manhattan District History, Central Facilities, Railroad System", dated 20 December 1946, with 2 incls., and 1st Memorandum Indorsement, Department of Public Works, Facilities and Service Division, dated 6 January 1947, with 2 incls.	Files, Control Department, Facilities and Service Division, Manhattan District, Oak Ridge, Tennessee
294	Subcontract No. 70 (C-9808), Stone & Webster Engineering Corporation with R. B. Tyler, Inc.; and Subcontract No. 107 (C-17689), Stone & Webster Engineering Corporation with Dave L. Brown	Manhattan District Contract Files, Oak Ridge, Tennessee
295	Contract No. W-7418-eng-3, with Ralph Rogers Company	Manhattan District Contract Files, Oak Ridge, Tennessee
296	Constructive Cash Expenditures & Receipts to Date & Estimated Constructive Cash Expenditures & Receipts...December 1946, Cumulative....(Roane-Anderson Company), with 1 incl.	Files, Control Department, Facilities and Service Division, Manhattan District, Oak Ridge, Tennessee
297	Memorandum, Oak Ridge Public Schools, subject: "Number of School Employees as of December 31, 1946", dated 7 January 1947	Files, Control Department, Facilities and Service Division, Manhattan District, Oak Ridge, Tennessee

<u>No.</u>	<u>Description</u>	<u>Location</u>
298	Memorandum, Oak Ridge Public Schools, subject: "Membership in Oak Ridge Schools as Per December 31", dated 8 January 1947	Files, Control Department, Facilities and Service Division, Manhattan District, Oak Ridge, Tennessee
299	Memorandum, Department of Public Welfare, Facilities and Service Division, Manhattan District, subject: "Manhattan District History, Central Facilities, School System", dated 7 January 1947	Files, Control Department, Facilities and Service Division, Manhattan District, Oak Ridge, Tennessee
300	Copy, Determination W. D. 88-U. S. Engineers -1-A, Office of the Chief of Transportation, Washington, D. C., dated 11 October 1946	Files, Control Department, Facilities and Service Division, Manhattan District, Oak Ridge, Tennessee
301	File: "Dormitory Statistical Trend from 1 July 1946 to 31 December 1946"	Files, Housing Section, Administrative Department, Facilities and Service Division, Manhattan District, Oak Ridge, Tennessee
302	Revegetation and Erosion Control Cost Report	Files, Roads and Streets Department, Roane-Anderson Company, Oak Ridge, Tennessee
303	Memorandum, Department of Public Works, Facilities and Service Division, Manhattan District, subject: "Manhattan District History, Central Facilities, Road System", dated 16 January 1947, with 1 incl.	Files, Control Department, Facilities and Service Division, Manhattan District, Oak Ridge, Tennessee

<u>No.</u>	<u>Description</u>	<u>Location</u>
304	Subcontract No. 32, with R. E. Martin Company, under Contract No. W-7421-eng-11, with J. A. Jones Construction Company	Manhattan District Contract Files, Oak Ridge, Tennessee
305	Subcontract No. 10, with Osmen-Creighton Construction Company, under Contract No. W-7421-eng-11, with J. A. Jones Construction Company	Manhattan District Contract Files, Oak Ridge, Tennessee
306	Memorandum, Control Department, Facilities and Service Division, Manhattan District, subject: "Additional Information for History", dated 9 January 1947, with 3 incls., and 1st Memorandum Indorsement, Department of Public Works, Facilities and Service Division, dated 14 January 1947, with 4 incls.	Files, Control Department, Facilities and Service Division, Manhattan District, Oak Ridge, Tennessee
307	Letter, Roane-Anderson Company, dated 17 January 1947, file: 600.15 (R-A)	Files, Control Department, Facilities and Service Division, Manhattan District, Oak Ridge, Tennessee
308	Contract No. W-17-028-eng-132, with John A. Johnson Contracting Corporation	Manhattan District Contract Files, Oak Ridge, Tennessee
309	Contract No. W-44-153-eng-41, with Fletcher-Moore Company	Manhattan District Contract Files, Oak Ridge, Tennessee
310	Contract No. W-31-109-eng-45, with Engineering and Equipment Company	Manhattan District Contract Files, Oak Ridge, Tennessee
311	Contract No. W-22-075-eng-131, with Clinton Construction Company	Manhattan District Contract Files, Oak Ridge, Tennessee

<u>No.</u>	<u>Description</u>	<u>Location</u>
312	Contract No. W-31-109-eng-87, with John A. Johnson Contracting Corporation	Manhattan District Contract Files, Oak Ridge, Tennessee
313	Contract No. W-31-109-eng-82, with John A. Johnson Contracting Corporation	Manhattan District Contract Files, Oak Ridge, Tennessee
314	Letter, Roane-Anderson Company, dated 17 December 1946 (File No. Man. 600.15, R-A)	Files, Control Department, Facilities and Service Division, Manhattan District, Oak Ridge, Tennessee
315	Concessions Reports (Monthly), Roane-Anderson Company	Files, Concessions and Subcontracts Section, Administrative Department, Facilities and Service Division, Manhattan District, Oak Ridge, Tennessee
316	Memorandum, Department of Public Safety, Facilities and Service Division, subject: "Manhattan District History, Central Facilities, Security System", dated 27 January 1947	Files, Control Department, Facilities and Service Division, Manhattan District, Oak Ridge, Tennessee
317	Memorandum, Control Department, Facilities and Service Division, Manhattan District, subject: "Manhattan District History, Central Facilities, Communications", dated 18 December 1946, with 1 incl., and 1st Memorandum Indorsement, Communications Department, Facilities and Service Division, dated 29 January 1947, with 3 incls.	Files, Control Department, Facilities and Service Division, Manhattan District, Oak Ridge, Tennessee

<u>No.</u>	<u>Description</u>	<u>Location</u>
318	Fiscal and Control Section Records	Files, Communications Department, Facilities and Service Division, Manhattan District, Oak Ridge, Tennessee
319	Manhattan District Consolidated Force Report, Contractor Employment, dated 31 December 1946	Files, Office of the Chief of the Facilities and Service Division, Manhattan District, Oak Ridge, Tennessee
320	Memorandum, Electric Power Division, subjects "Manhattan District History", dated 3 February 1947, with 5 incls.	Files, Control Department, Facilities and Service Division, Manhattan District, Oak Ridge, Tennessee
321	Contract No. W-31-109-eng-34, with Clinton Power Commission	Manhattan District Contract Files, Oak Ridge, Tennessee
322	Contract No. W-26-021-eng-132, with Lenoir City Water and Light Department	Manhattan District Contract Files, Oak Ridge, Tennessee
323	Contract No. W-31-109-eng-69, with Harriman Power Department	Manhattan District Contract Files, Oak Ridge, Tennessee
324	Contract No. W-22-075-eng-74, with Fort Loudoun Electric Cooperative	Manhattan District Contract Files, Oak Ridge, Tennessee
325	Project Cost Summary, Military Funds, Contracts	Files, Cost Section, Administrative Division, Manhattan District, Oak Ridge, Tennessee

<u>No.</u>	<u>Description</u>	<u>Location</u>
326	Statistical Summary Charts (Monthly), American Industrial Transit Bus Operations	Files, Bus Transportation Section, Department of Public Works, Facilities and Service Division, Manhattan District, Oak Ridge, Tennessee
327	Minutes, Central Facilities Advisory Committee, 13 July 1944	Files, Office of the Chief of the Facilities and Service Division, Manhattan District, Oak Ridge, Tennessee
328	Memorandum, Stone & Webster Engineering Corporation to files, dated 24 June 1943, subject: "Accounting for Trailer Camp Revenues and Expense."	Manhattan District Files, Oak Ridge, Tennessee
329	Letter, Crenshaw to Roane-Anderson Company, dated 18 January 1944 (relating to reduction in trailer rental rates).	Files, Department of Public Works, Facilities and Service Division, Manhattan District, Oak Ridge, Tennessee
330	Letter, Crenshaw to Stone & Webster Engineering Corporation, dated 18 January 1944 (relating to reduction in trailer rental rates).	Files, Department of Public Works, Facilities and Service Division, Manhattan District, Oak Ridge, Tennessee
331	Letter, Kelley to Tennessee Eastman Corporation, dated 18 January 1944 (relating to reduction in trailer rental rates).	Files, Department of Public Works, Facilities and Service Division, Manhattan District, Oak Ridge, Tennessee

<u>No.</u>	<u>Description</u>	<u>Location</u>
332	Minutes, Central Facilities Advisory Committee, 10 August 1944	Files, Office of the Chief of the Facilities and Service Division, Manhattan District, Oak Ridge, Tennessee
333	Letter, Hodgson to Roane-Anderson Company, dated 12 August 1944 (relating to reduction of trailer rentals).	Files, Department of Public Works, Facilities and Service Division, Manhattan District, Oak Ridge, Tennessee
334	Letter, Hodgson to Tennessee Eastman Corporation, dated 9 October 1944 (relating to trailer rentals).	Manhattan District Files, Oak Ridge, Tennessee
335	Teletype, Nichols to Johnson, dated 12 October 1944 (relating to trailer rentals).	Manhattan District Files, Oak Ridge, Tennessee
336	Memorandum, Curtin to Crawford, subject: "Progress of Car Sharing Program", dated 17 June 1944.	Files, Bus Transportation Section, Department of Public Works, Facilities and Service Division, Manhattan District, Oak Ridge, Tennessee
337	Memorandum, Crawford to the Files, subject: "Ride Sharing on the Area", dated 1 July 1944	Files, Bus Transportation Section, Department of Public Works, Facilities and Service Division, Manhattan District, Oak Ridge, Tennessee
338	Letter, O'Wears to Roane-Anderson Company (relating to ride sharing program), dated 25 May 1944	Files, Bus Transportation Section, Department of Public Works, Facilities and Service Division, Manhattan District, Oak Ridge, Tennessee

<u>No.</u>	<u>Description</u>	<u>Location</u>
339	Memorandum, Warren to Taylor, Tennessee Eastman Corporation, subject: "Share-the-Ride Program Committee", dated 23 May 1944	Files, Bus Transportation Section, Department of Public Works, Facilities and Service Division, Manhattan District, Oak Ridge, Tennessee
340	Memorandum, Bus Authority, Roane-Anderson Company, to CNW Transportation Board (relating to car sharing), dated 4 May 1944	Files, Bus Transportation Section, Department of Public Works, Facilities and Service Division, Manhattan District, Oak Ridge, Tennessee
341	Memorandum, Manager of Administration, Tennessee Eastman Corporation, to All Employees, subject: "Low Cost Share-the-Ride Plan", dated 14 December 1943	Files, Bus Transportation Section, Department of Public Works, Facilities and Service Division, Manhattan District, Oak Ridge, Tennessee
342	Memorandum, Travis to Wosterchil, subject: "Share-A-Ride Clearing House", dated 5 October 1943	Files, Bus Transportation Section, Department of Public Works, Facilities and Service Division, Manhattan District, Oak Ridge, Tennessee
343	Memorandum, Travis to Wosterchil, subject: "Suggestion No. 32, Ideas for Victory", dated 18 September 1943, with 1 incl.	Files, Bus Transportation Section, Department of Public Works, Facilities and Service Division, Manhattan District, Oak Ridge, Tennessee

~~SECRET~~

~~SECRET~~

<u>No.</u>	<u>Description</u>	<u>Location</u>
344	Memorandum, Diamond to Curtin, "Tennessee Laws Affecting 'Share the Ride' Plans," dated 27 March 1944	Files, Bus Transportation Section, Department of Public Works, Facilities and Service Division, Manhattan District, Oak Ridge, Tennessee
345	Letters (identical), Curtin to Ford, Bacon and Davis, Inc.; Stone & Webster Engineering Corporation; and Tennessee Eastman Corporation (all relating to car sharing); dated 23 May 1944	Files, Bus Transportation Section, Department of Public Works, Facilities and Service Division, Manhattan District, Oak Ridge, Tennessee
346	Letter, Curtin to National Conservation Bureau, dated 2 June 1944	Files, Bus Transportation Section, Department of Public Works, Facilities and Service Division, Manhattan District, Oak Ridge, Tennessee
347	Letter, National Conservation Bureau to CNW Transportation Board, dated 6 June 1944	Files, Bus Transportation Section, Department of Public Works, Facilities and Service Division, Manhattan District, Oak Ridge, Tennessee
348	Letter, Curtin to Roane-Anderson Company (listing car sharing exchanges), dated 25 July 1944	Files, Bus Transportation Section, Department of Public Works, Facilities and Service Division, Manhattan District, Oak Ridge, Tennessee

<u>No.</u>	<u>Description</u>	<u>Location</u>
349	Memorandum, Counsell to Bloch, subject: "Request for Work Order", 15 August 1944	Files, Bus Transportation Section, Department of Public Works, Facilities and Service Division, Manhattan District, Oak Ridge, Tennessee
350	Memorandum, Hernandez to Division Heads, Roane-Anderson Company (relating to trailer operations), dated 22 May 1944	Files, Division of Accounts, Roane-Anderson Company, Oak Ridge, Tennessee
351	Memorandum, Russell to Bloom (relating to trailer operations), dated 29 May 1944	Files, Division of Accounts, Roane-Anderson Company, Oak Ridge, Tennessee
352	Letter, Zbanek to Roane-Anderson Company, subject: "Trailer Rentals", dated 20 May 1946	Files, Division of Accounts, Roane-Anderson Company, Oak Ridge, Tennessee
353	Letter, Roane-Anderson Company to Gibson Service Management Company, subject: "Trailer Rentals", dated 24 May 1946	Files, Division of Accounts, Roane-Anderson Company, Oak Ridge, Tennessee

~~CONFIDENTIAL~~

MANHATTAN DISTRICT HISTORY
BOOK I - GENERAL
VOLUME 12 - CLINTON ENGINEER WORKS, CENTRAL FACILITIES
APPENDIX B - MAPS

~~CONFIDENTIAL~~

MANHATTAN DISTRICT HISTORY

BOOK I - GENERAL

VOLUME 12 - CLINTON ENGINEER WORKS, CENTRAL FACILITIES

APPENDIX B - MAPS

<u>NO.</u>	<u>TITLE</u>
1	Location Map, Clinton Engineer Works
2	Vicinity Map, CEW
3	Reservation Map, CEW
4	Map, Oak Ridge (2 Sheets)
5	Shoppers' Guide, Oak Ridge
6	Electric Power Distribution System, CEW
6a	Electric Power Distribution and Supply, CEW
7	Original Water Supply System, Oak Ridge
8	Water Supply System, Oak Ridge, November 1944
9	Water Supply System, Oak Ridge, 31 December 1946
10	Access Roads, CEW, November 1944
11	Central Railroad System, CEW
12	Bus Transportation Map, Off-Area, February 1944 to January 1945
12a	Bus Transportation Map, Off-Area, February 1945 to December 1945
13	Road System, CEW, 29 May 1945
13a	Road System, CEW, 1 April 1946
13b	Road System, CEW, 31 December 1946
14	Sewerage System, Oak Ridge, 31 December 1946

B-1 LOCATION MAP, CLINTON ENGINEER WORKS

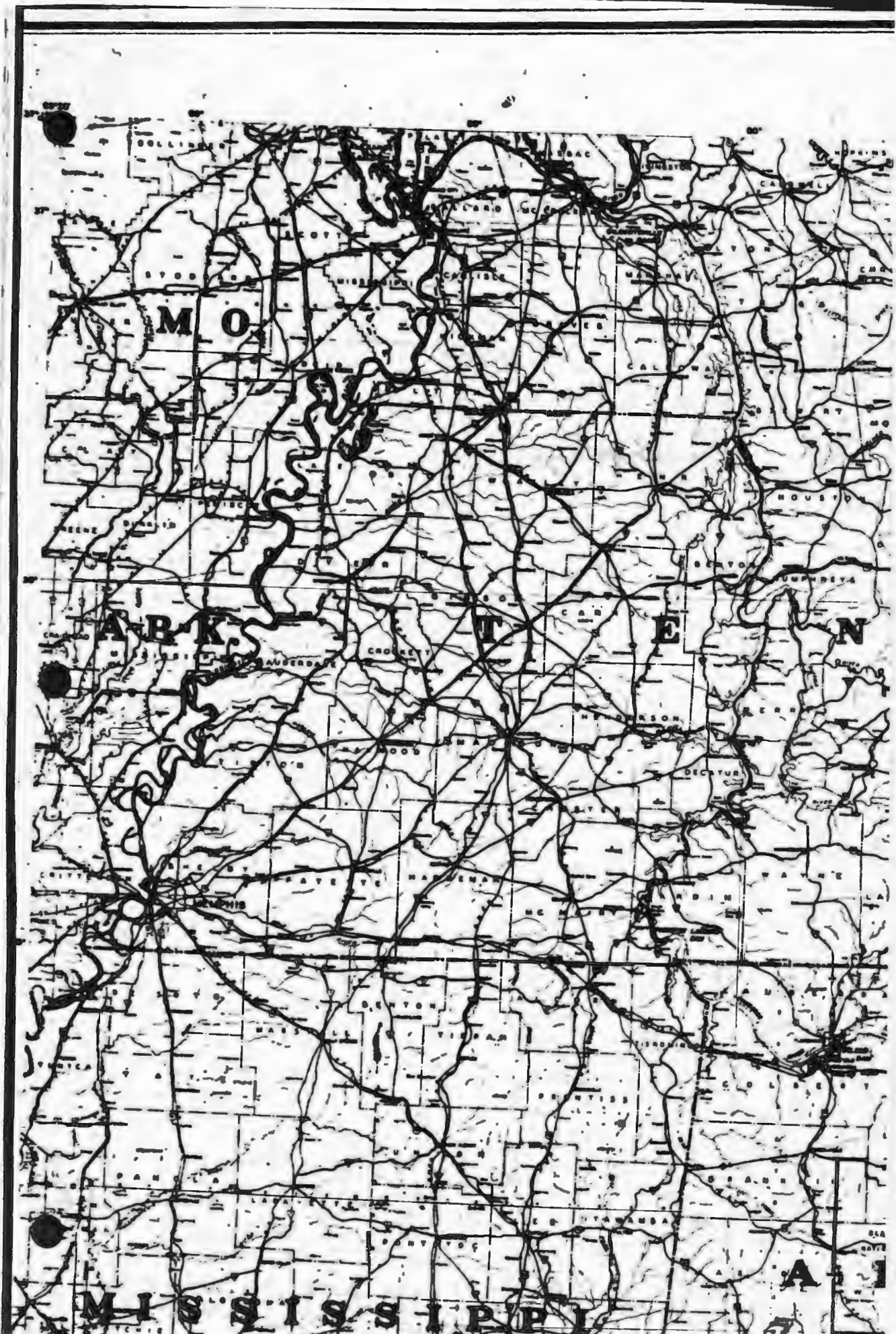



CEW-2

TENNESSEE VALLEY AUTHORITY
MAPS AND SURVEYS DIVISION

MAP OF THE TENNESSEE VALLEY REGION

SCALE OF MILES
0 10 20 30 40 50
SEPTEMBER 1934

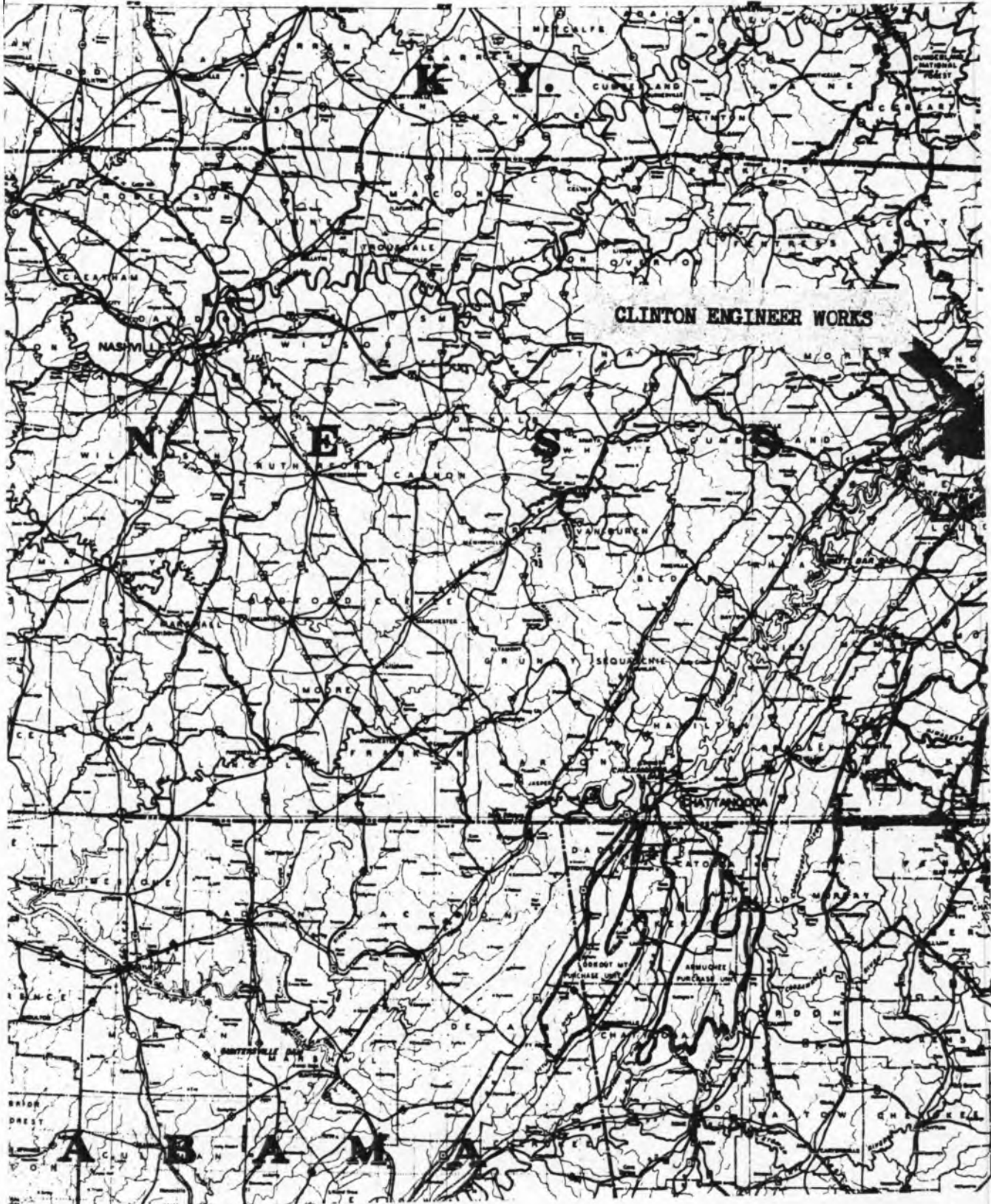

0EW-3

CLINTON ENGINEER WORKS

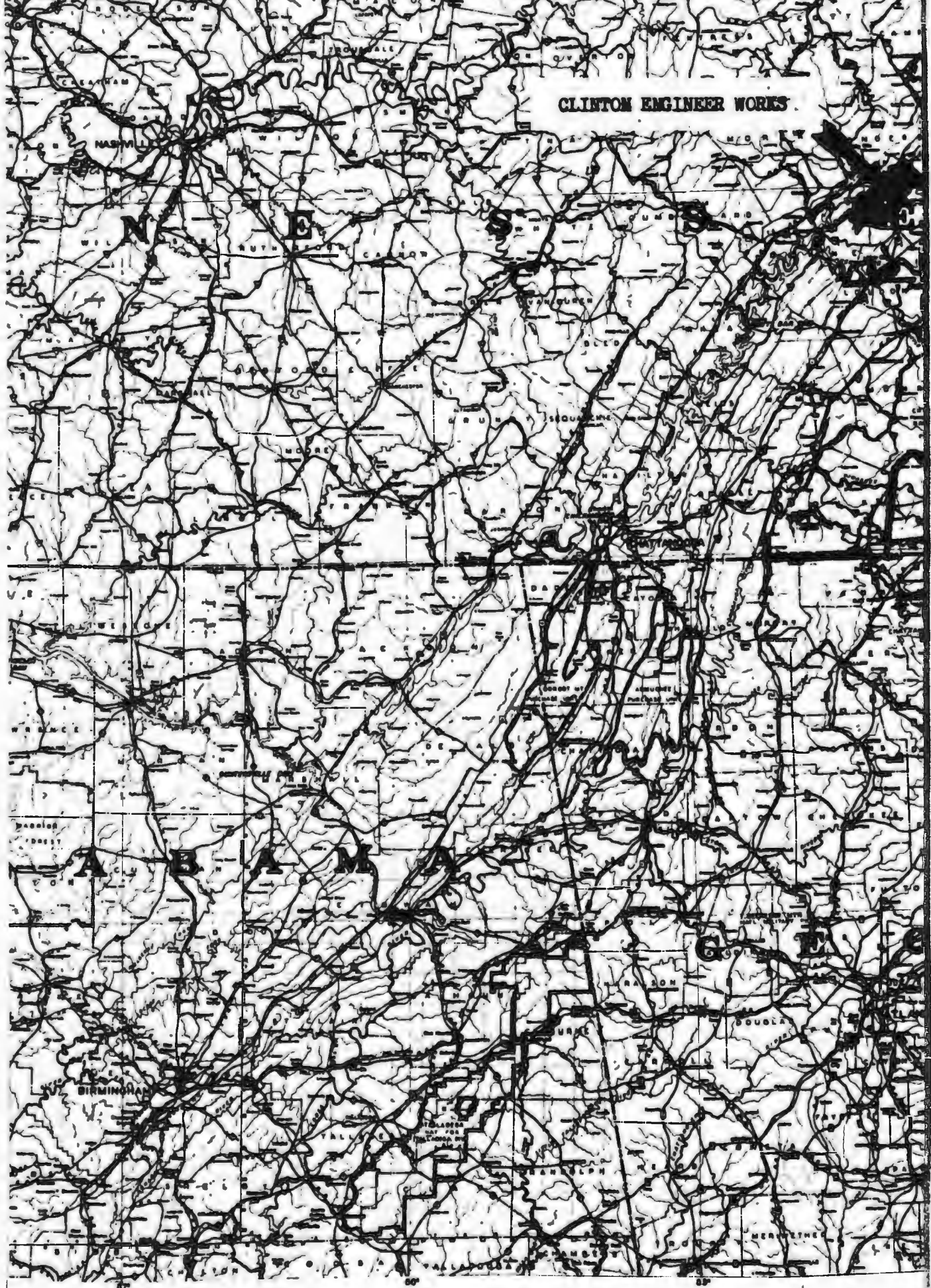

CEW-5

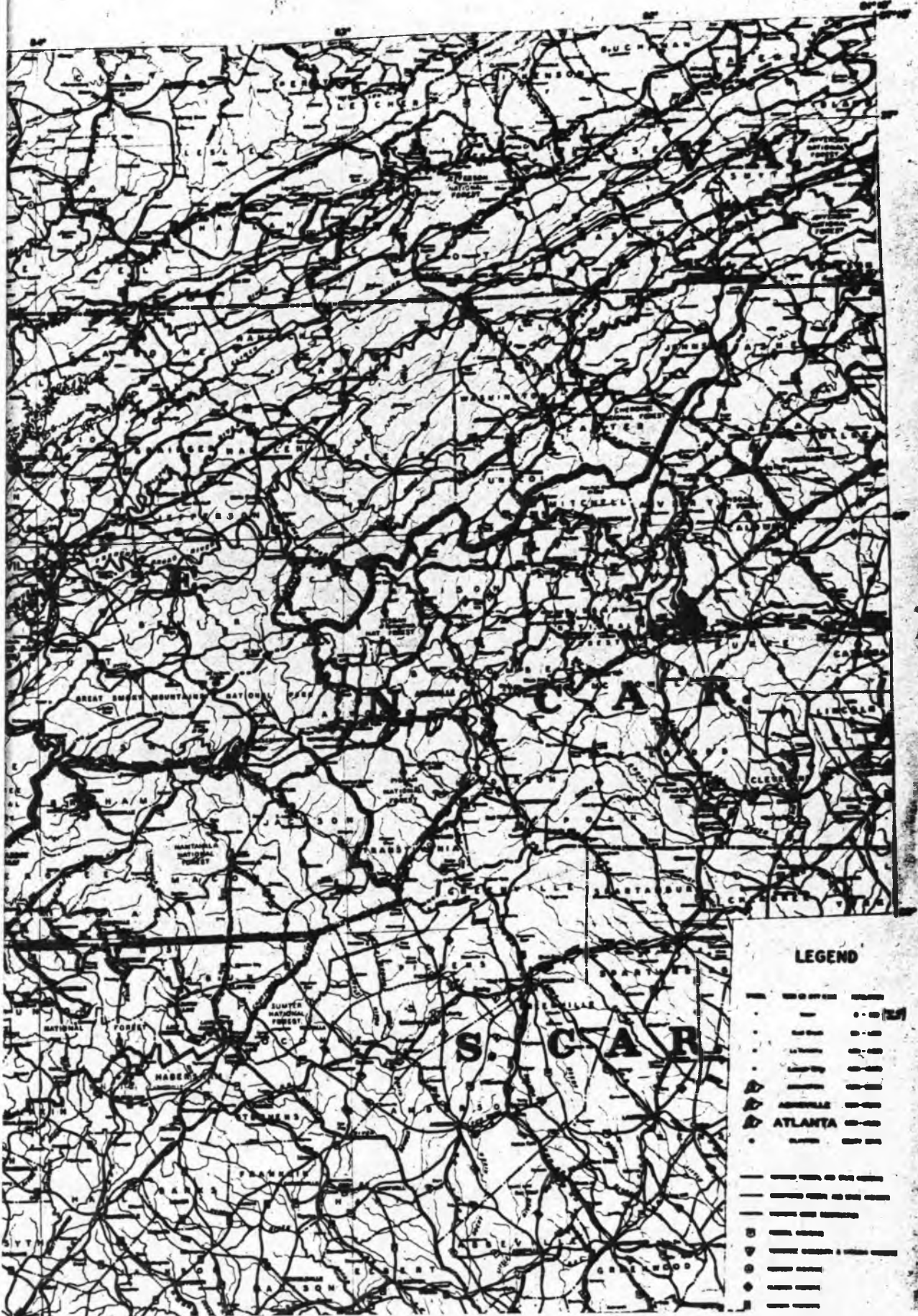

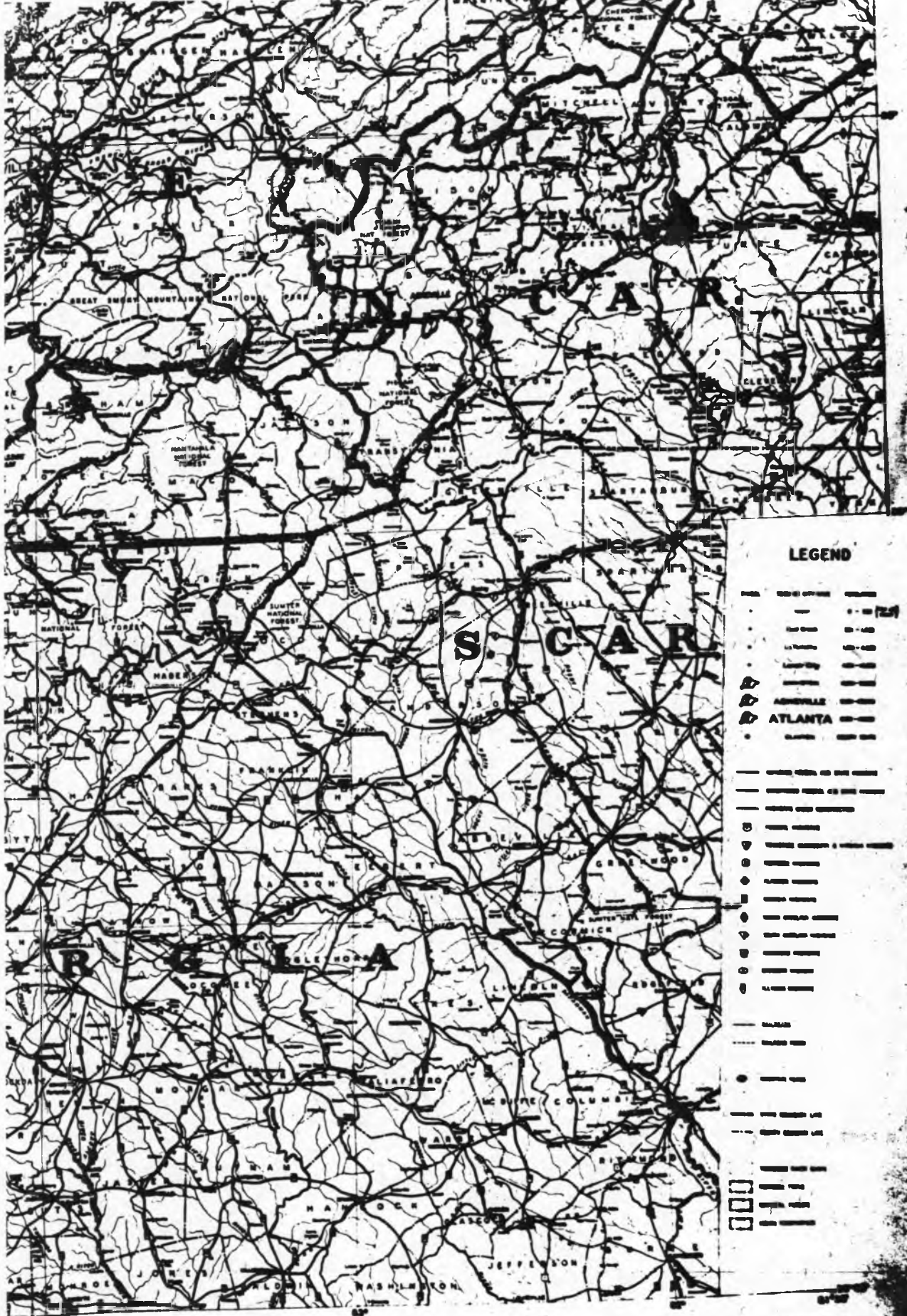

LEGEND

(Symbol)	(Symbol)	(Symbol)
(Symbol)	(Symbol)	(Symbol)
(Symbol)	(Symbol)	(Symbol)
(Symbol)	(Symbol)	(Symbol)
(Symbol)	(Symbol)	(Symbol)
(Symbol)	(Symbol)	(Symbol)
(Symbol)	(Symbol)	(Symbol)
(Symbol)	(Symbol)	(Symbol)
(Symbol)	(Symbol)	(Symbol)
(Symbol)	(Symbol)	(Symbol)
(Symbol)	(Symbol)	(Symbol)
(Symbol)	(Symbol)	(Symbol)
(Symbol)	(Symbol)	(Symbol)
(Symbol)	(Symbol)	(Symbol)
(Symbol)	(Symbol)	(Symbol)
(Symbol)	(Symbol)	(Symbol)
(Symbol)	(Symbol)	(Symbol)
(Symbol)	(Symbol)	(Symbol)
(Symbol)	(Symbol)	(Symbol)
(Symbol)	(Symbol)	(Symbol)
(Symbol)	(Symbol)	(Symbol)
(Symbol)	(Symbol)	(Symbol)
(Symbol)	(Symbol)	(Symbol)
(Symbol)	(Symbol)	(Symbol)

R-2 VICINITY MAP, GEN

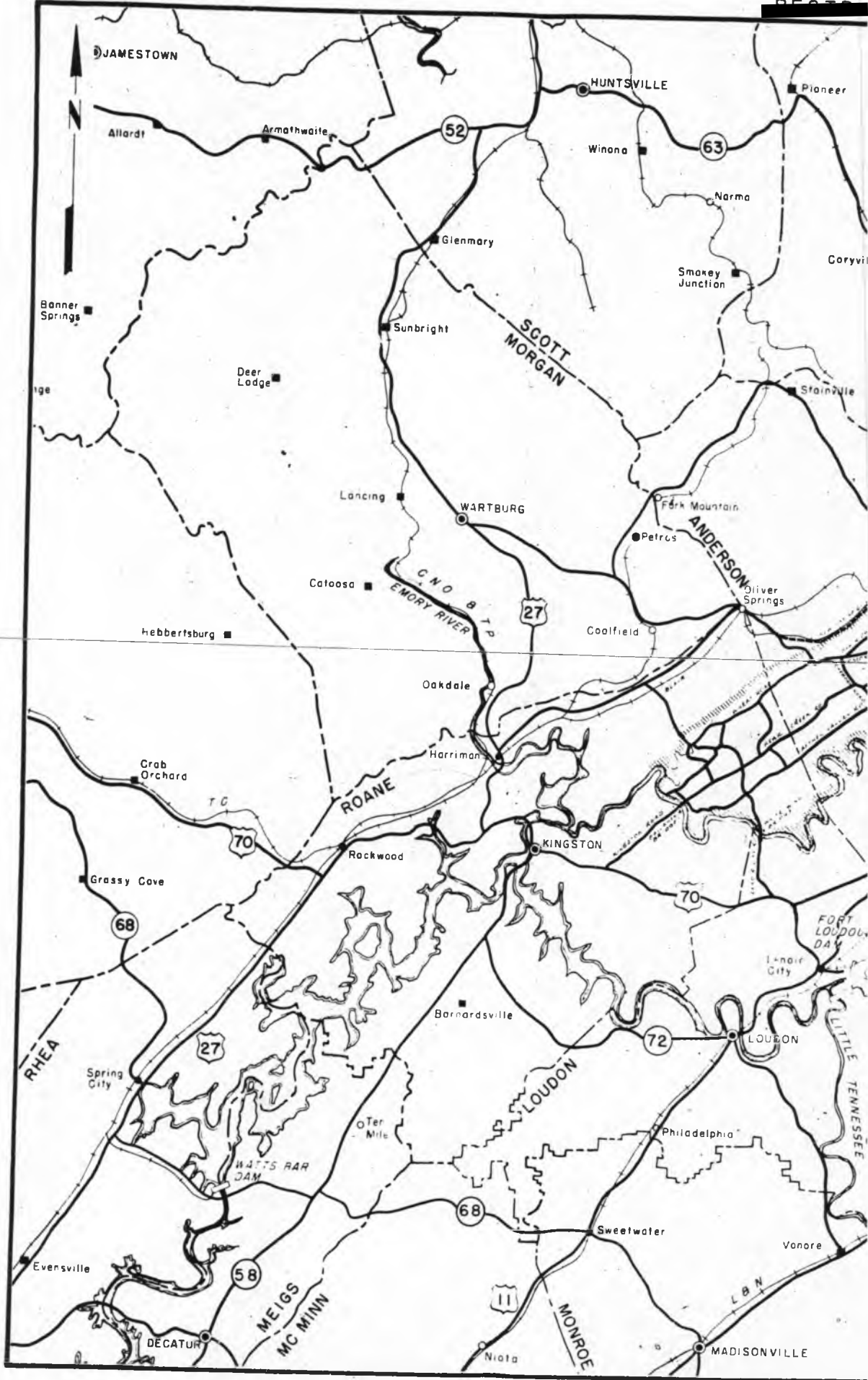

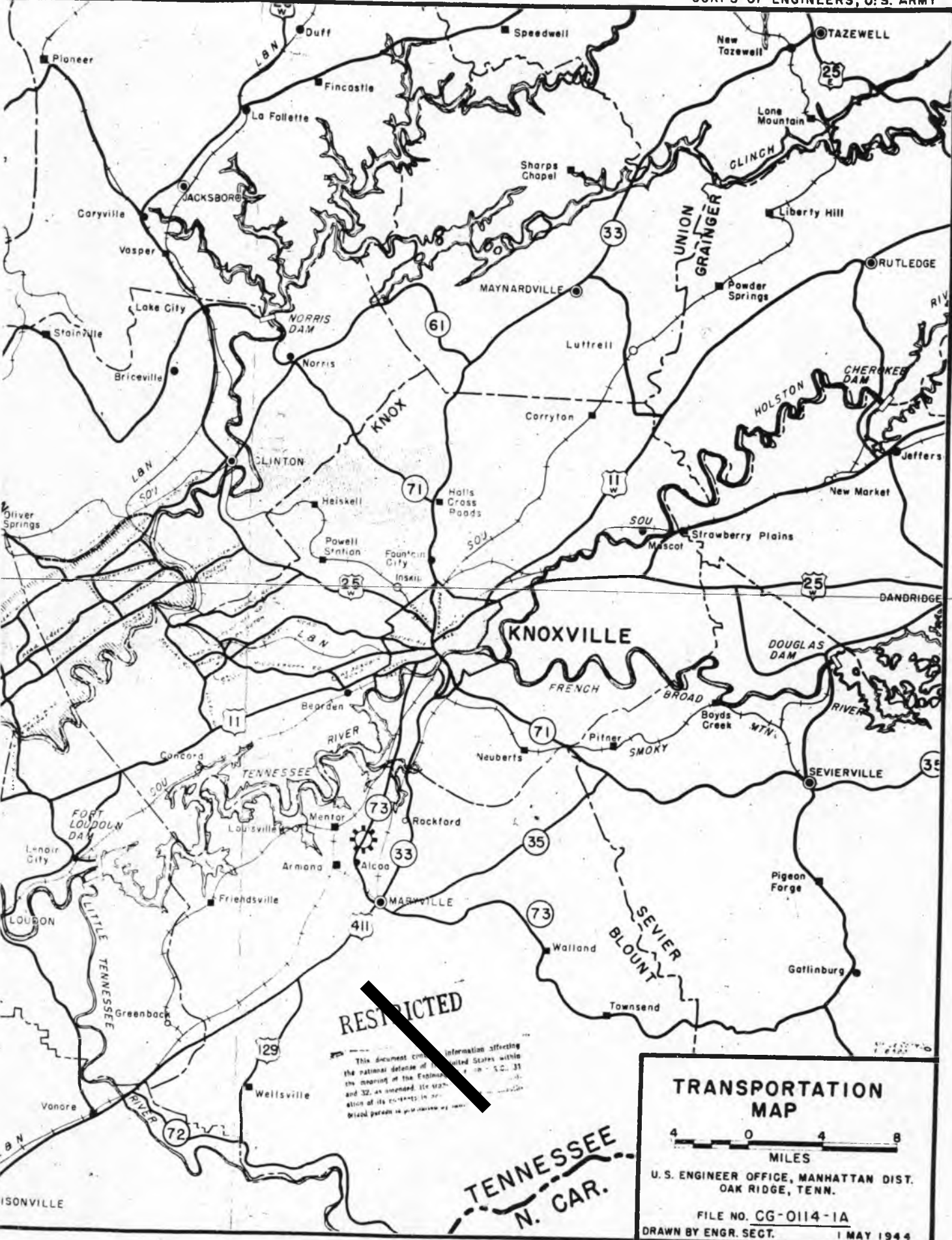

RESTRICTED

This document contains information affecting the national defense of the United States within the meaning of the Espionage Laws, Title 18, U.S.C., Sec. 793 and 794, as amended, the transmission or revelation of its contents in any manner to an unauthorized person is prohibited by law.

TENNESSEE
N. CAR.

**TRANSPORTATION
MAP**



U.S. ENGINEER OFFICE, MANHATTAN DIST.
OAK RIDGE, TENN.

FILE NO. CG-0114-1A
DRAWN BY ENGR. SECT. 1 MAY 1944

B-3 RESERVATION MAP, GEN

- ACCESS RD & RR R/W EXTENDS TO SOUTHERN R.R. (BLAIR)

ACCESS RD R/W EXTENDS TO U.S. HWY NO 70

FILE NO. CK-0111-1,2

FILE NO. CX-0111-1

FILE NO. CG-0111-FORK

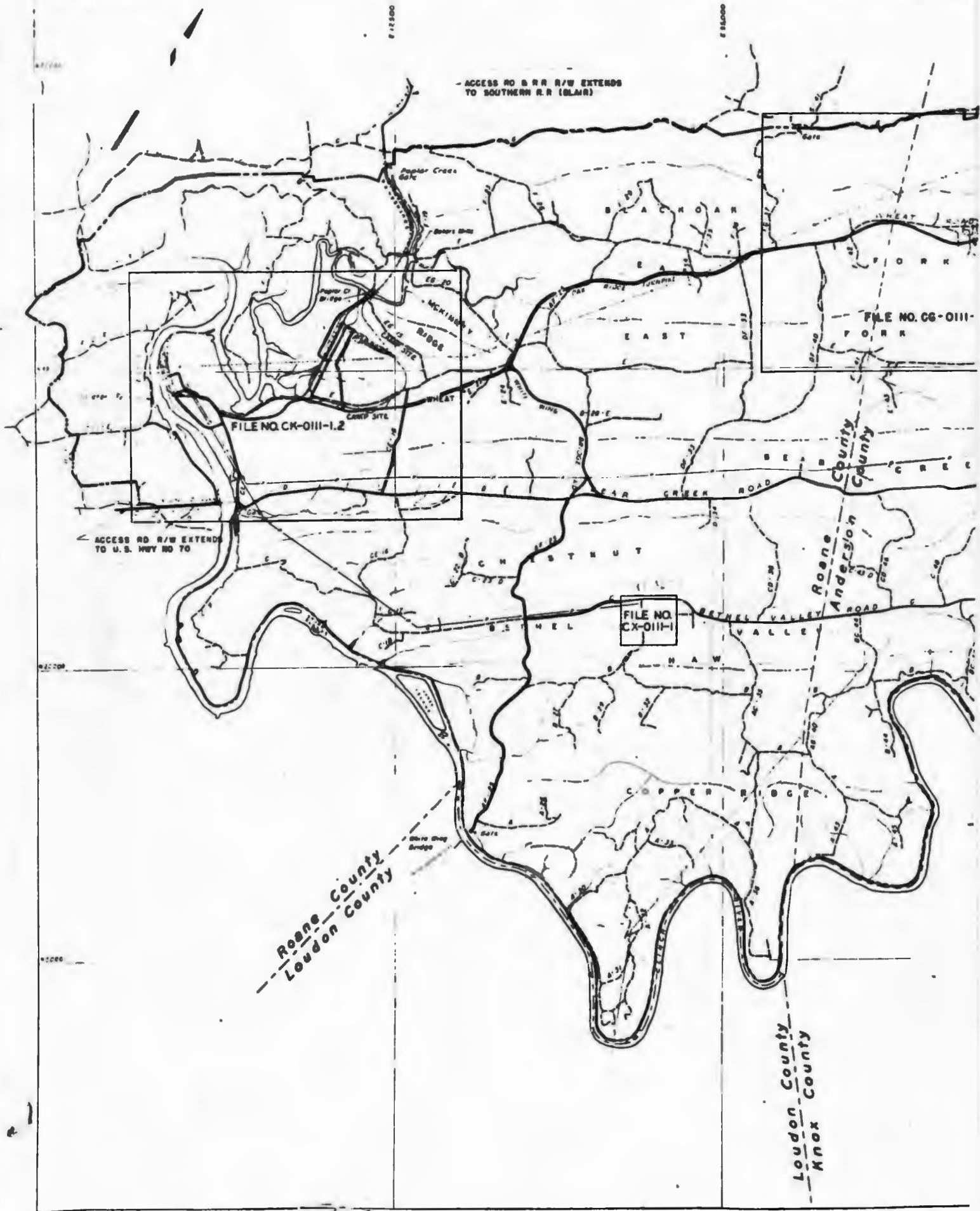

Roane County
Loudon County

Loudon County
Knox County

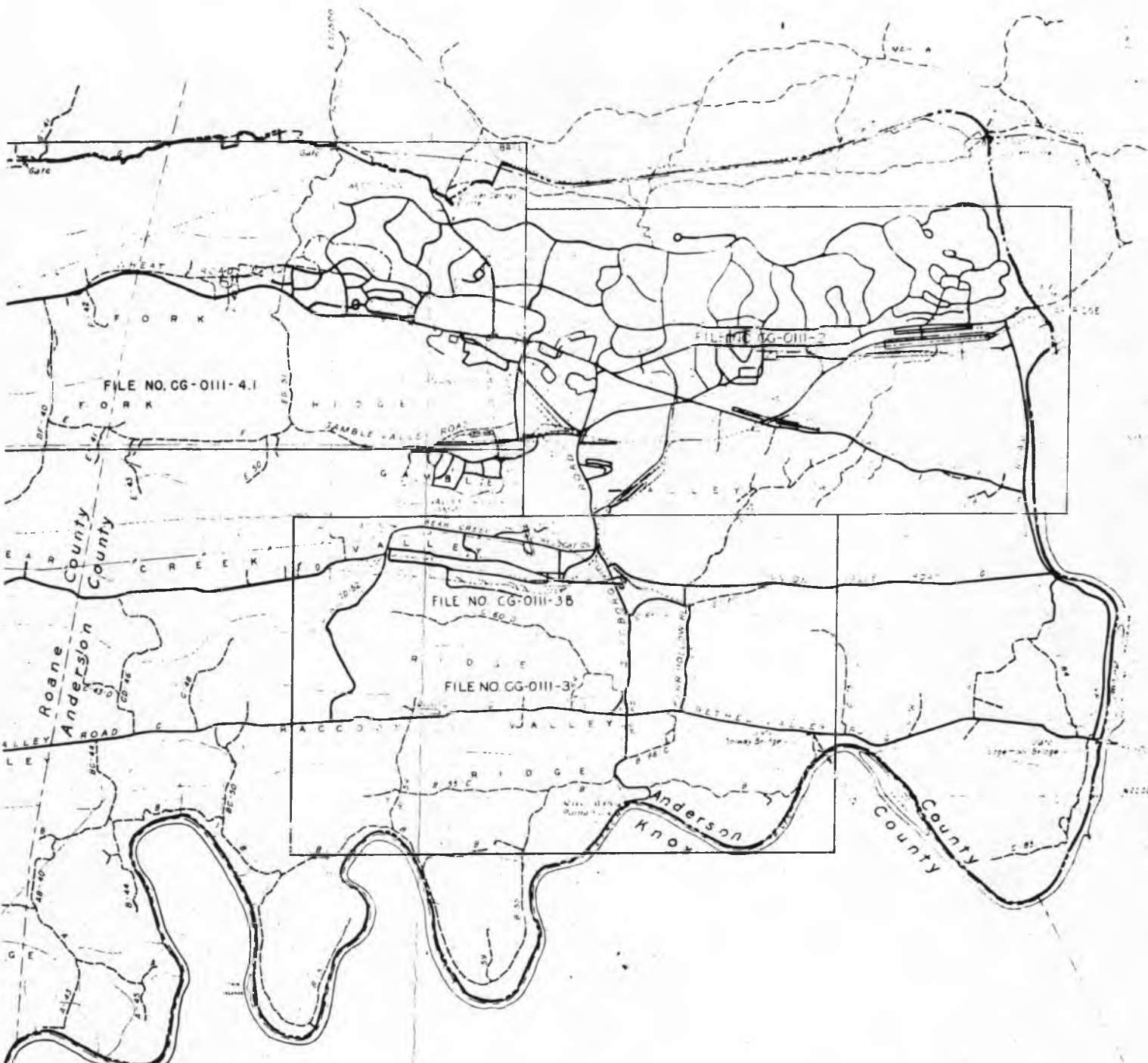

LEGEND

- NEW AND IMPROVED ROADS COMPLETED
- NEW ROADS UNDER CONSTRUCTION
- EXISTING SECONDARY ROADS
- RAILROADS COMPLETED
- RAILROADS UNDER CONSTRUCTION
- PROPERTY LINE

NO.	DATE	REVISION
1	7-3-34	INITIAL PROGRAM
2	7-3-34	REVISED PROGRAM
3	7-3-34	REVISED PROGRAM
4	7-3-34	REVISED PROGRAM
5	7-3-34	REVISED PROGRAM
6	7-3-34	REVISED PROGRAM
7	7-3-34	REVISED PROGRAM
8	7-3-34	REVISED PROGRAM
9	7-3-34	REVISED PROGRAM
10	7-3-34	REVISED PROGRAM

**INDEX AND ROAD MAP
STATUS OF CONSTRUCTION**

U.S. ENGR OFFICE - MANHATTAN DIST. KNOXVILLE, TENN. JULY 3, 1934

FILE NO. CG-0111-1

DATE

REV BY CK BY AP BY

THIS MAP IS THE PROPERTY OF THE U.S. ARMY ENGINEERING DISTRICT OFFICE, KNOXVILLE, TENN. IT IS TO BE USED ONLY FOR THE PURPOSES FOR WHICH IT WAS DESIGNED AND IS NOT TO BE REPRODUCED OR TRANSMITTED IN ANY FORM OR BY ANY MEANS, ELECTRONIC OR MECHANICAL, INCLUDING PHOTOCOPYING, RECORDING, OR BY ANY INFORMATION STORAGE AND RETRIEVAL SYSTEM.

H-4 MAP, OAK RIDGE (2 Sheets)

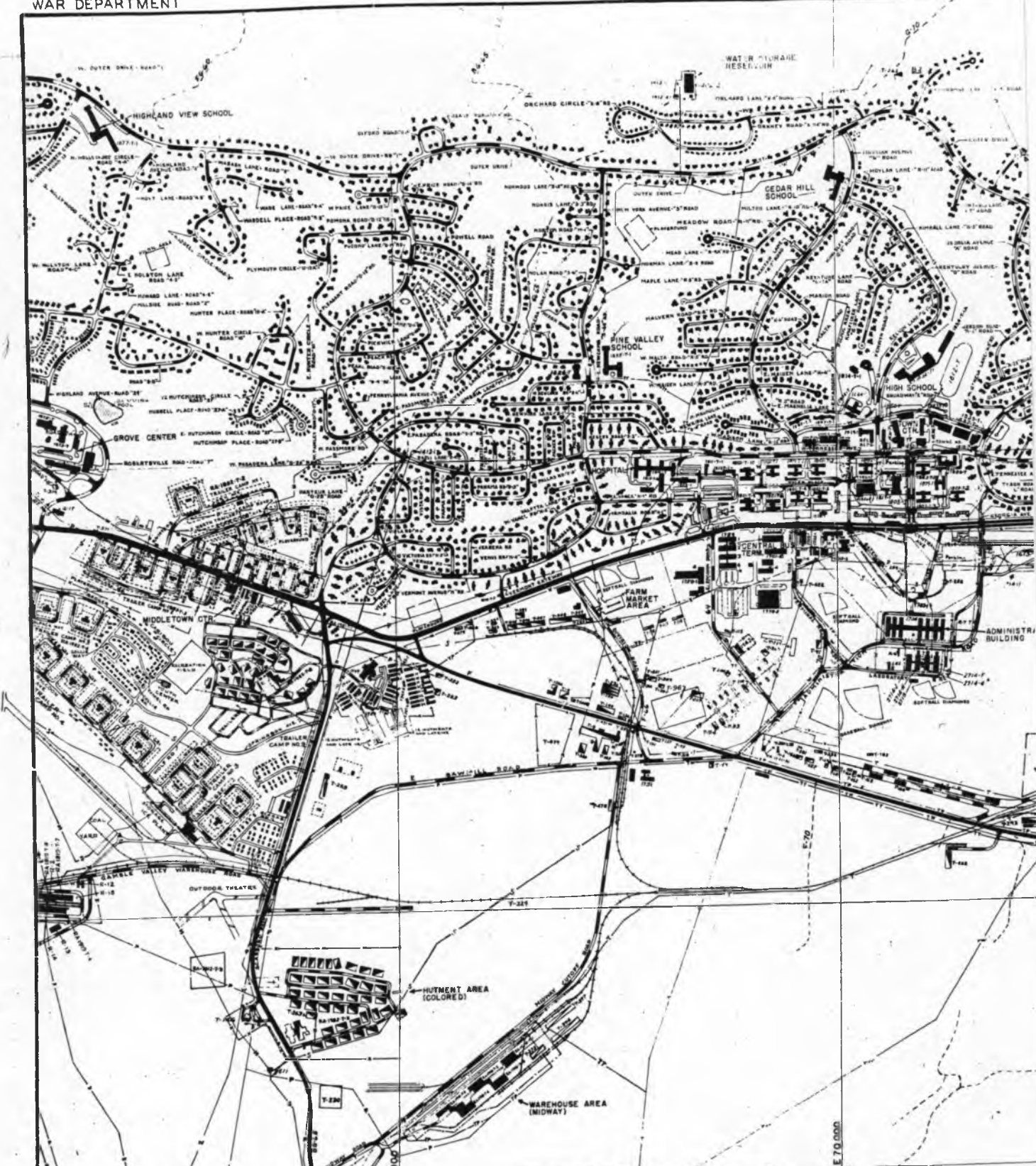

FE. 122E
143

LEGEND					
PERMANENT BLDGS.		PERMANENT ROADS		RAILROADS	
<ul style="list-style-type: none"> Proposed Under Const. Completed 	<ul style="list-style-type: none"> Proposed Under Const. Completed 	<ul style="list-style-type: none"> Existing Improved Regulding Unimproved 	<ul style="list-style-type: none"> Proposed Under Const. Completed Secondary Completed Primary Proposed 	<ul style="list-style-type: none"> Main Line Proposed Under Const. Completed 	<ul style="list-style-type: none"> Temporary TS TS TS TS Completed Under Const.
TEMPORARY BLDGS.		NEW		ELECTRIC LINES	
<ul style="list-style-type: none"> Proposed Under Const. Comp. Etes 	<ul style="list-style-type: none"> Proposed Under Const. Completed 	<ul style="list-style-type: none"> Completed Under Const. Proposed 	<ul style="list-style-type: none"> Completed Under Const. Proposed 	<ul style="list-style-type: none"> Permanent Type Completed Under Const. 	<ul style="list-style-type: none"> Temporary TS TS TS TS Completed Under Const.
MISCELLANEOUS		TEMPORARY ROADS		SEWER LINES	
<ul style="list-style-type: none"> Property Line Existing Church Existing School Existing Cemetery 	<ul style="list-style-type: none"> Proposed Completed 	<ul style="list-style-type: none"> Completed Under Const. Proposed 	<ul style="list-style-type: none"> Completed Under Const. Proposed 	<ul style="list-style-type: none"> Completed Under Const. Proposed 	<ul style="list-style-type: none"> Completed Under Const. Proposed
				WATER LINES	
				<ul style="list-style-type: none"> Completed Under Const. Proposed 	<ul style="list-style-type: none"> Completed Under Const. Proposed
				TELEP	
				<ul style="list-style-type: none"> Completed Under Const. Proposed 	<ul style="list-style-type: none"> Completed Under Const. Proposed
				TOWNSHIP	
				<ul style="list-style-type: none"> Completed Under Const. Proposed 	<ul style="list-style-type: none"> Completed Under Const. Proposed
				STEAM LINE	
				<ul style="list-style-type: none"> Completed Under Const. Proposed 	<ul style="list-style-type: none"> Completed Under Const. Proposed

21109-V

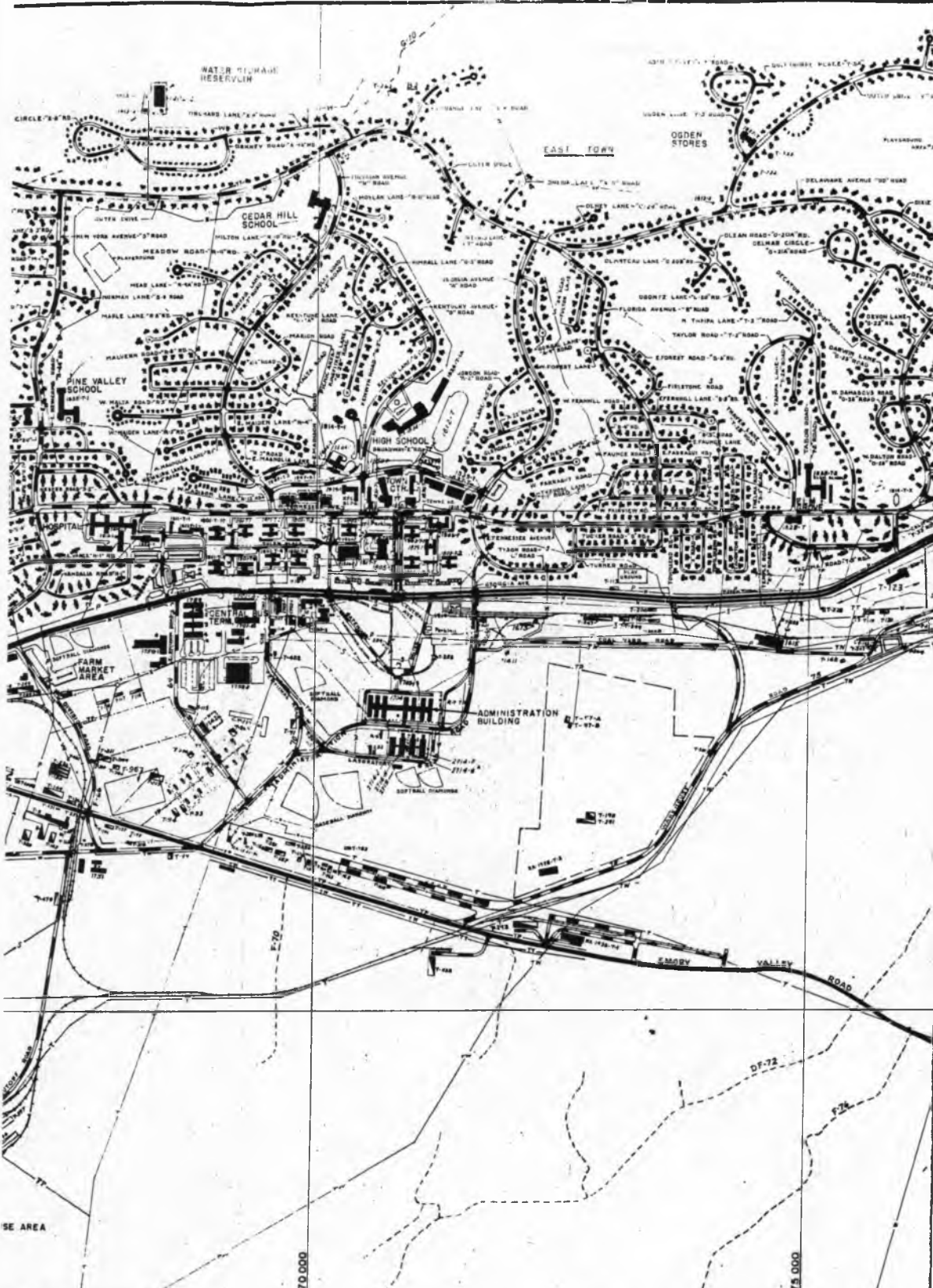

LEGEND
ROADS
 MAIN LINE
 PROPOSED
 UNDER CONST.
 COMPLETED

SEWER LINES
 TEMPORARY
 COMPLETED
 UNDER CONST.

TELEPHONE LINES
 PERMANENT
 TEMPORARY
 EXISTING

ELECTRIC LINES
 COMPLETED
 UNDER CONST.
 EXISTING

WATER LINES
 TEMPORARY
 COMPLETED
 UNDER CONST.

TOWNSITE HOUSE TYPES
 A, B, C, D, E, F

ADDITION	6-30-43	CONSTRUCTION PROGRAM BROUGHT UP TO DATE AS OF JUNE 30, 1943	S.L.T.
ADDITION	7-31-44	CONSTRUCTION PROGRAM BROUGHT UP TO DATE AS OF SEPTEMBER 30, 1944	S.E.W.
ADDITION	11-30-44	CONSTRUCTION PROGRAM BROUGHT UP TO DATE AS OF NOVEMBER 30, 1944	S.E.W.
ADDITION	10-31-44	CONSTRUCTION PROGRAM BROUGHT UP TO DATE AS OF OCTOBER 31, 1944	S.E.W.
ADDITION	1-30-44	CONSTRUCTION PROGRAM BROUGHT UP TO DATE AS OF SEPTEMBER 30, 1943	S.E.W.
ADDITION	8-31-44	CONSTRUCTION PROGRAM BROUGHT UP TO DATE AS OF AUGUST 31, 1944	S.E.W.

R41P 9-29

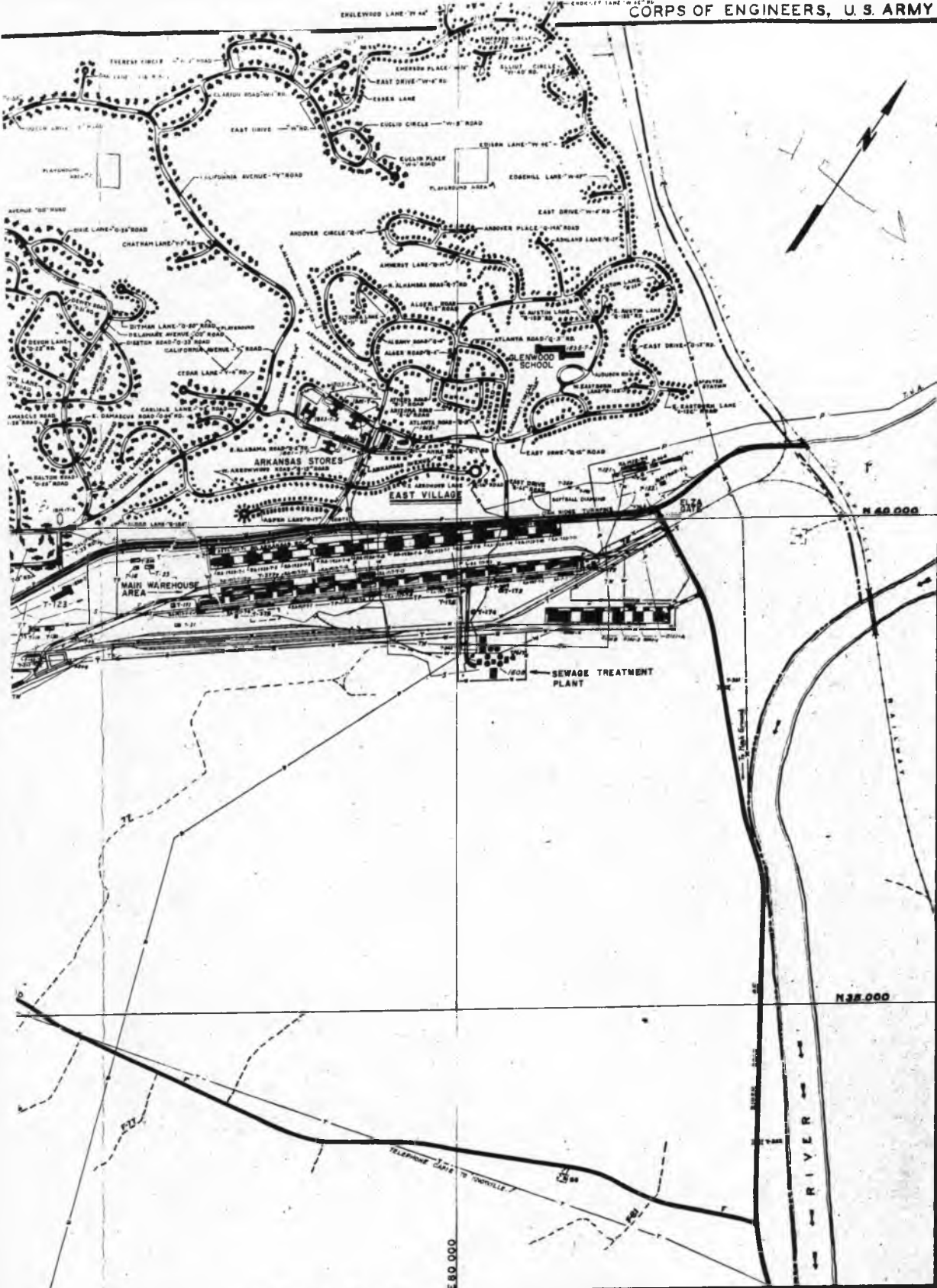

ADDITION	DATE	CONSTRUCTION PROGRAM BROUGHT UP TO DATE AS OF DATE	S.E.W.
ADDITION	7-31-44	CONSTRUCTION PROGRAM BROUGHT UP TO DATE AS OF JULY 31, 1944	S.E.W.
ADDITION	6-30-44	CONSTRUCTION PROGRAM BROUGHT UP TO DATE AS OF JUNE 30, 1944	S.E.W.
ADDITION	5-31-44	CONSTRUCTION PROGRAM BROUGHT UP TO DATE AS OF MAY 31, 1944	S.E.W.
ADDITION	4-30-44	CONSTRUCTION PROGRAM BROUGHT UP TO DATE AS OF APRIL 30, 1944	S.E.W.
ADDITION	3-31-44	CONSTRUCTION PROGRAM BROUGHT UP TO DATE AS OF MARCH 31, 1944	S.E.W.
ADDITION	2-29-44	CONSTRUCTION PROGRAM BROUGHT UP TO DATE AS OF FEBRUARY 29, 1944	S.E.W.
ADDITION	1-31-44	CONSTRUCTION PROGRAM BROUGHT UP TO DATE AS OF JANUARY 31, 1944	S.E.W.
ADDITION	12-31-43	CONSTRUCTION PROGRAM BROUGHT UP TO DATE AS OF DECEMBER 31, 1943	S.E.W.
ADDITION	11-30-43	CONSTRUCTION PROGRAM BROUGHT UP TO DATE AS OF NOVEMBER 30, 1943	S.E.W.
ADDITION	10-31-43	CONSTRUCTION PROGRAM BROUGHT UP TO DATE AS OF OCTOBER 31, 1943	S.E.W.
ADDITION	9-30-43	CONSTRUCTION PROGRAM BROUGHT UP TO DATE AS OF SEPTEMBER 30, 1943	S.E.W.
ADDITION	8-31-43	CONSTRUCTION PROGRAM BROUGHT UP TO DATE AS OF AUGUST 31, 1943	S.E.W.
ADDITION	7-31-43	CONSTRUCTION PROGRAM BROUGHT UP TO DATE AS OF JULY 31, 1943 WITH EXCEPTION TORRANTE HOUSES	S.E.W.
		TYPE DATE REVISION	REV. BY CR. BY AP BY

TOWNSITE, ADMINISTRATION AREA AND WAREHOUSE AREA

LOCATION PLAN AND STATUS OF CONSTRUCTION

600' 0" 1200'

U. S. ENGR OFFICE, MANHATTAN DIST, KNOXVILLE, TENN. JUN. 30, 1943

SUBMITTED: <i>C. J. Wood</i> S.E.W.	RECOMMENDED: <i>Paul Brown</i> S.E.W.	APPROVED: <i>Thomas J. ...</i> S.E.W.
DRAWN BY: <i>[Signature]</i>		FILE NO. CG-0111-2
CHECKED BY: <i>[Signature]</i>		TRANSMITTED WITH LETTER OR ENDORSEMENT DATED:



GAMBLE VALLEY TRAILER CAMP INSERT

LEGEND			
<p>PERMANENT BLDGS.</p> <p>Proposed: [Symbol]</p> <p>Under Const: [Symbol]</p> <p>Completed: [Symbol]</p> <p>TEMPORARY BLDGS.</p> <p>Proposed: [Symbol]</p> <p>Under Const: [Symbol]</p> <p>Completed: [Symbol]</p> <p>MISCELLANEOUS</p> <p>PROPERTY LINE: [Symbol]</p> <p>EXISTING CHURCH: [Symbol]</p> <p>EXISTING SCHOOL: [Symbol]</p> <p>EXISTING CEMETERY: [Symbol]</p> <p>FENCE: [Symbol]</p>	<p>PERMANENT ROADS</p> <p>EXISTING: [Symbol]</p> <p>NEW: [Symbol]</p> <p>IMPROVED: [Symbol]</p> <p>REBUILDING: [Symbol]</p> <p>UNIMPROVED: [Symbol]</p> <p>UNDER CONST.: [Symbol]</p> <p>COMPLETED SECONDARY: [Symbol]</p> <p>COMPLETED PRIMARY: [Symbol]</p> <p>PROPOSED: [Symbol]</p> <p>TEMPORARY ROADS</p> <p>PROPOSED: [Symbol]</p> <p>COMPLETED: [Symbol]</p>	<p>RAILROADS</p> <p>MAIN LINE: [Symbol]</p> <p>PROPOSED: [Symbol]</p> <p>UNDER CONST.: [Symbol]</p> <p>COMPLETED: [Symbol]</p> <p>ELECTRIC LINES</p> <p>PERMANENT TYPE: [Symbol]</p> <p>TEMPORARY TYPE: [Symbol]</p> <p>COMPLETED: [Symbol]</p> <p>UNDER CONST.: [Symbol]</p> <p>COMPLETED: [Symbol]</p> <p>UNDER CONST.: [Symbol]</p> <p>EXISTING: [Symbol]</p>	<p>SEWER</p> <p>TEMPORARY: [Symbol]</p> <p>PERMANENT: [Symbol]</p> <p>WATER</p> <p>TEMPORARY: [Symbol]</p> <p>PERMANENT: [Symbol]</p>

R41P2-1

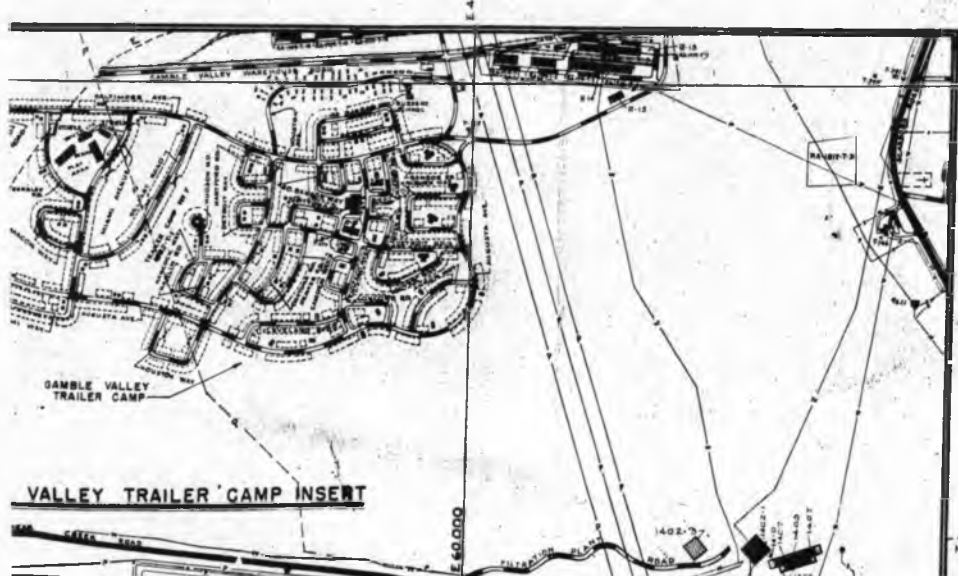
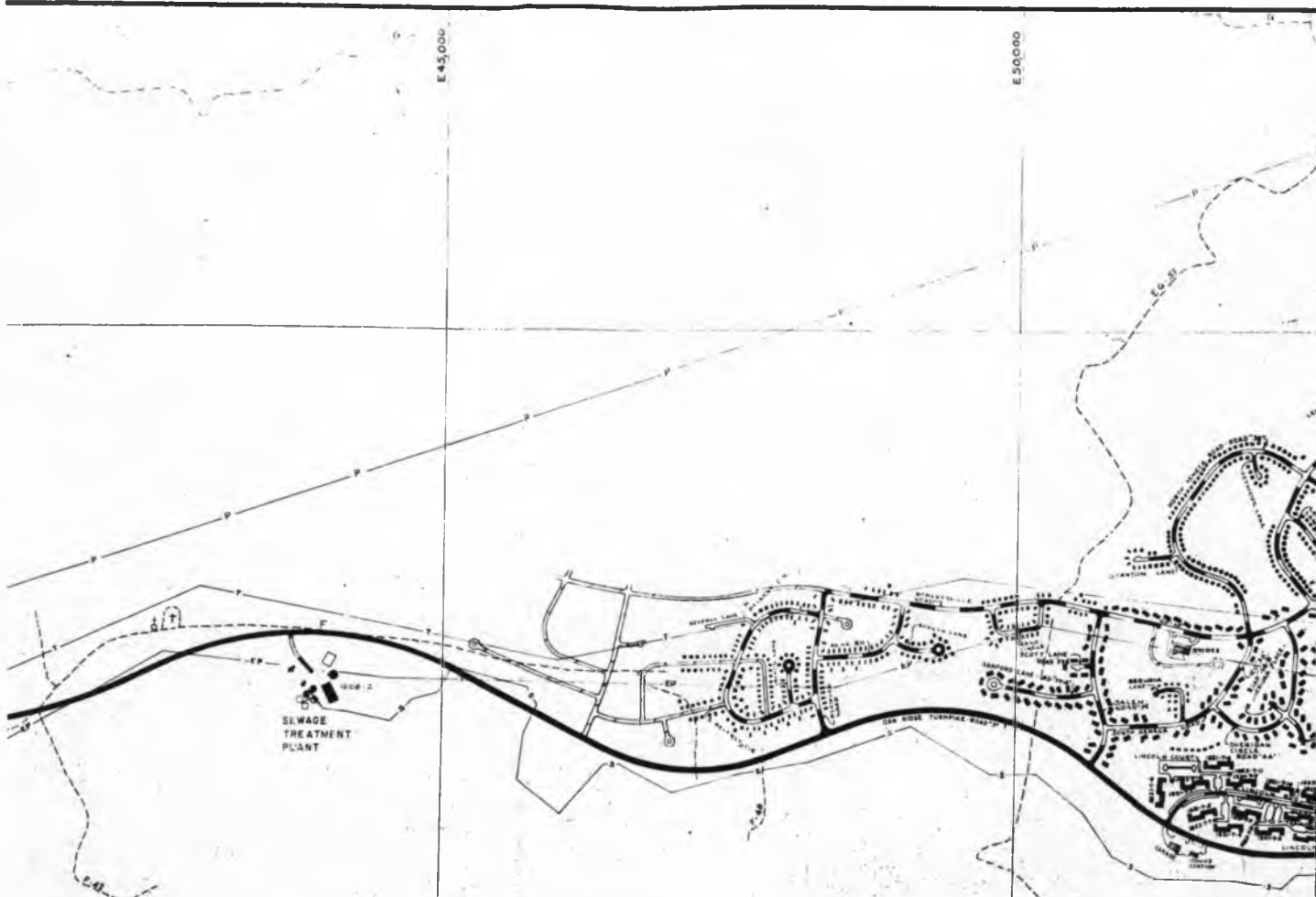

RAILROADS		SEWER LINES		TELEPHONE LINES	
—●—●—●—	MAIN LINE	—TS—	COMPLETED	—T—T—	PERMANENT
—○—○—○—	PROPOSED	—T3—	UNDER CONST.	—TT—TT—	TEMPORARY
—+—+—+—	UNDER CONST.	—T3—	UNDER CONST.	—ET—ET—	EXISTING
—+—+—+—	COMPLETED	—S—S—	COMPLETED		
		—S—S—	UNDER CONST.		
ELECTRIC LINES		WATER LINES		TOWNSITE HOUSE TYPES	
—P—P—P—	PERMANENT	—TW—	COMPLETED	A - a	C - c
—P—P—P—	TYPE P	—TW—TW—	UNDER CONST.	B - b	D - d
—T—T—T—	COMPLETED	—W—	COMPLETED	E - e	F - f
—T—T—T—	TYPE T	—W—W—	UNDER CONST.		
—EP—EP—EP—	TEMPORARY				
—EP—EP—EP—	TYPE EP				
—EP—EP—EP—	COMPLETED				
—EP—EP—EP—	TYPE EP				
—EP—EP—EP—	UNDER CONST.				
—EP—EP—EP—	TYPE EP				
—EP—EP—EP—	EXISTING				

EDITION	B-30-48	CONSTRUCTION PROGRAM BROUGHT UP TO DATE	N. S. M.
ADDITION	B-30-45	AS OF SEPTEMBER 30, 1948	S. I. T.
TYPE	DATL	REVISION	REV BY CK BY AP

RAIP2-2

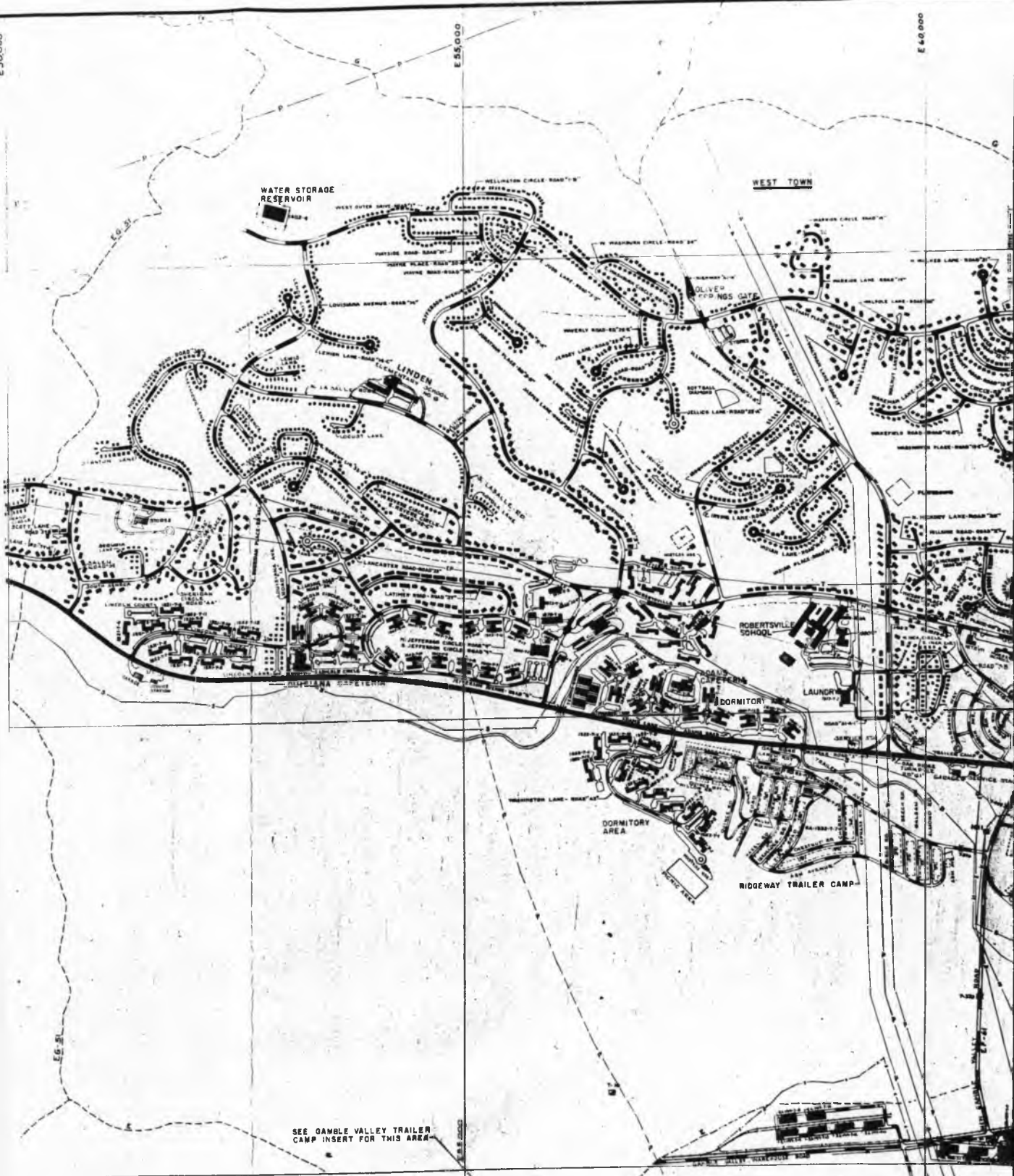

SEE DANBLE VALLEY TRAILER CAMP INSERT FOR THIS AREA

REVISION	REV BY	CHK BY	AP BY	TYPE	DATE	REVISION	REV BY	CHK BY	AP BY
ADDITION	4-30-44					CONSTRUCTION PROGRAM BROUGHT UP TO DATE AS OF DECEMBER 31, 1943			
ADDITION	10-30-44					CONSTRUCTION PROGRAM BROUGHT UP TO DATE AS OF DECEMBER 31, 1944			
ADDITION	10-31-44					CONSTRUCTION PROGRAM BROUGHT UP TO DATE AS OF DECEMBER 31, 1944			
ADDITION	4-30-44					CONSTRUCTION PROGRAM BROUGHT UP TO DATE AS OF JANUARY 31, 1944			
ADDITION	8-31-44					CONSTRUCTION PROGRAM BROUGHT UP TO DATE AS OF AUGUST 31, 1944			
ADDITION	7-31-44					CONSTRUCTION PROGRAM BROUGHT UP TO DATE AS OF JUNE 30, 1944			
ADDITION	4-30-44					CONSTRUCTION PROGRAM BROUGHT UP TO DATE AS OF JUNE 30, 1944			
ADDITION	3-31-44					CONSTRUCTION PROGRAM BROUGHT UP TO DATE AS OF JANUARY 31, 1944			
ADDITION	4-30-44					CONSTRUCTION PROGRAM BROUGHT UP TO DATE AS OF JANUARY 31, 1944			
ADDITION	3-31-44					CONSTRUCTION PROGRAM BROUGHT UP TO DATE AS OF JANUARY 31, 1944			
ADDITION	2-24-44					CONSTRUCTION PROGRAM BROUGHT UP TO DATE AS OF FEBRUARY 24, 1944			
REVISION	1-31-44					CONSTRUCTION PROGRAM BROUGHT UP TO DATE AS OF JANUARY 31, 1944			
ADDITION	3-31-43					CONSTRUCTION PROGRAM BROUGHT UP TO DATE AS OF DECEMBER 31, 1943			

TOWNSITE NO. 2 AREA
LOCATION PLAN AND
STATUS OF CONSTRUCTION

SCALE 1" = 400'

U.S. ENG'R OFFICE, MANHATTAN DIST, KNOXVILLE, TENN. JAN. 31, 1944

SUBMITTED:	RECOMMENDED:	APPROVED:
DESIGNED BY:	CHECKED BY:	DATE:
FILE NO. CG-0111-4.1	TRANSMITTED WITH LETTER OR ENGRAMMANT	

CONSTRUCTION PROGRAM BROUGHT UP TO DATE AS OF DECEMBER 31, 1943

CONSTRUCTION PROGRAM BROUGHT UP TO DATE AS OF DECEMBER 31, 1944

CONSTRUCTION PROGRAM BROUGHT UP TO DATE AS OF JANUARY 31, 1944

CONSTRUCTION PROGRAM BROUGHT UP TO DATE AS OF AUGUST 31, 1944

CONSTRUCTION PROGRAM BROUGHT UP TO DATE AS OF JUNE 30, 1944

CONSTRUCTION PROGRAM BROUGHT UP TO DATE AS OF JUNE 30, 1944

CONSTRUCTION PROGRAM BROUGHT UP TO DATE AS OF JANUARY 31, 1944

CONSTRUCTION PROGRAM BROUGHT UP TO DATE AS OF JANUARY 31, 1944

CONSTRUCTION PROGRAM BROUGHT UP TO DATE AS OF JANUARY 31, 1944

This document contains information affecting the national defense within the meaning of the espionage laws, and its transmission or revelation of its contents in any manner to an unauthorized person is prohibited by law.

B-5 SHOPPERS' GUIDE, OAK RIDGE

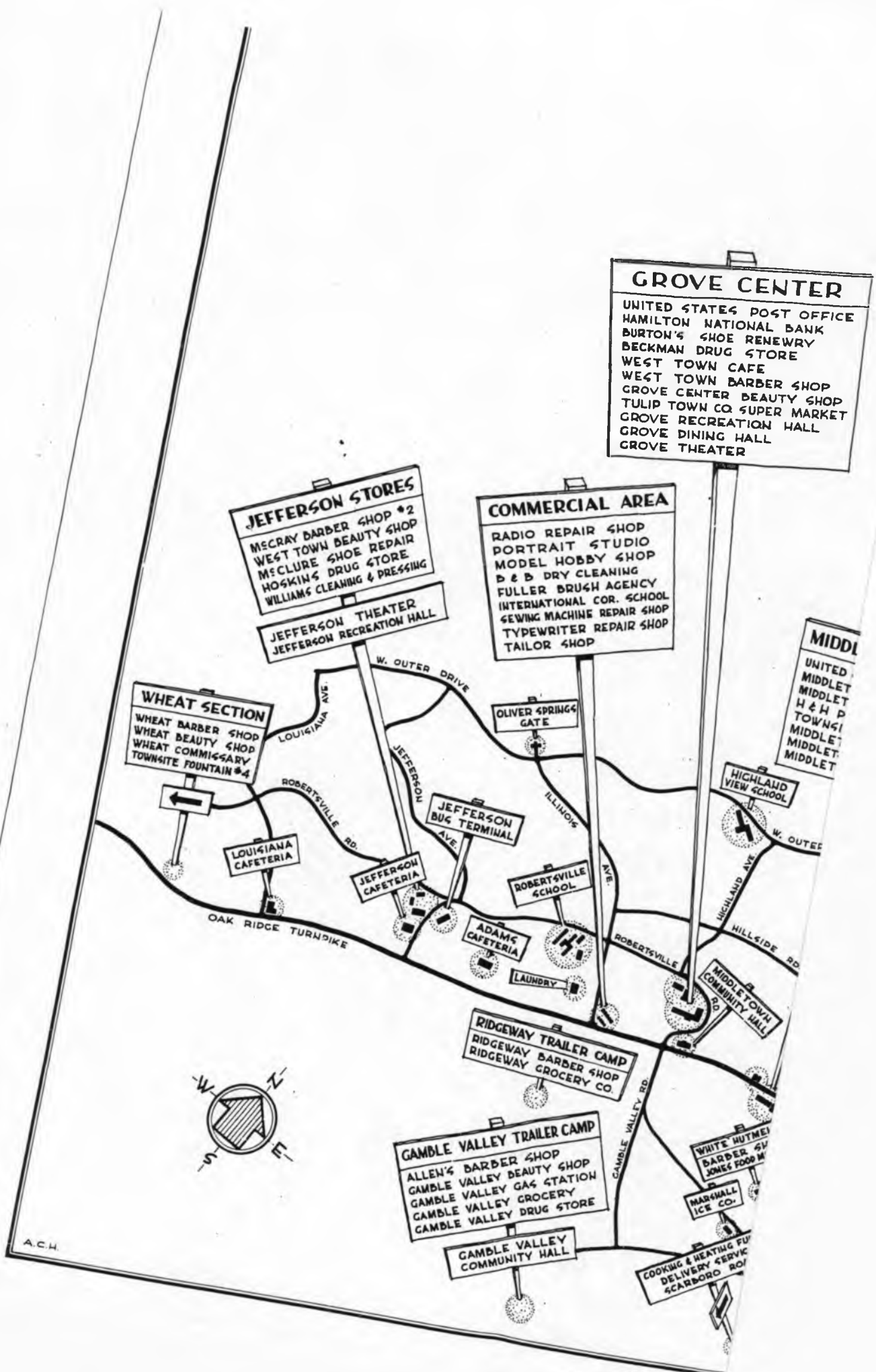

GROVE CENTER
 UNITED STATES POST OFFICE
 HAMILTON NATIONAL BANK
 BURTON'S SHOE REWEAVER
 BECKMAN DRUG STORE
 WEST TOWN CAFE
 WEST TOWN BARBER SHOP
 GROVE CENTER BEAUTY SHOP
 TULIP TOWN CO SUPER MARKET
 GROVE RECREATION HALL
 GROVE DINING HALL
 GROVE THEATER

JEFFERSON STORES
 MECRAY BARBER SHOP #2
 WEST TOWN BEAUTY SHOP
 MCCLURE SHOE REPAIR
 HOGKINS DRUG STORE
 WILLIAMS CLEANING & DRESSING

JEFFERSON THEATER
 JEFFERSON RECREATION HALL

COMMERCIAL AREA
 RADIO REPAIR SHOP
 PORTRAIT STUDIO
 MODEL HOBBY SHOP
 P & B DRY CLEANING
 FULLER BRUSH AGENCY
 INTERNATIONAL COR. SCHOOL
 SEWING MACHINE REPAIR SHOP
 TYPEWRITER REPAIR SHOP
 TAILOR SHOP

WHEAT SECTION
 WHEAT BARBER SHOP
 WHEAT BEAUTY SHOP
 WHEAT COMMISSARY
 TOWNSITE FOUNTAIN #4

MIDDLE
 UNITED MIDDLE
 MIDDLET
 MIDDLET
 H & P TOWNS
 MIDDLET
 MIDDLET
 MIDDLET

RIDGEWAY TRAILER CAMP
 RIDGEWAY BARBER SHOP
 RIDGEWAY GROCERY CO.

GAMBLE VALLEY TRAILER CAMP
 ALLEN'S BARBER SHOP
 GAMBLE VALLEY BEAUTY SHOP
 GAMBLE VALLEY GAS STATION
 GAMBLE VALLEY GROCERY
 GAMBLE VALLEY DRUG STORE

GAMBLE VALLEY COMMUNITY HALL

WHITE HUTMES
 BARBER SHOP
 JONES FOOD

MARSHALL
 ICE CO.

COOKING & HEATING FUEL
 DELIVERY SERVICE
 SCARBORO RD



A.C.H.

R5-1

GROVE CENTER
 UNITED STATES POST OFFICE
 HAMILTON NATIONAL BANK
 BURTON'S SHOE RENEWRY
 BECKMAN DRUG STORE
 WEST TOWN CAFE
 WEST TOWN BARBER SHOP
 GROVE CENTER BEAUTY SHOP
 TULIP TOWN CO. SUPER MARKET
 GROVE RECREATION HALL
 GROVE DINING HALL
 GROVE THEATER

PINE VALLEY STORES
 PINE VALLEY DRUG STORE
 PINE VALLEY BARBER SHOP
 PINE VALLEY BEAUTY SHOP
 C & S MARKET
 PINE VALLEY SHOE REPAIR

COMMERCIAL AREA
 RADIO REPAIR SHOP
 PORTRAIT STUDIO
 MODEL HOBBY SHOP
 B & B DRY CLEANING
 FULLER DRUG AGENCY
 INTERNATIONAL COR. SCHOOL
 SEWING MACHINE REPAIR SHOP
 TYPEWRITER REPAIR SHOP
 TAILOR SHOP

MIDDLETOWN CENTER
 UNITED STATES POST OFFICE
 MIDDLETOWN BARBER SHOP
 MIDDLETOWN SUPER MARKET
 H & H PRODUCE MARKET
 TOWNSITE FOUNTAIN #3
 MIDDLETOWN GAS STATION
 MIDDLETOWN MEAT MARKET
 MIDDLETOWN THEATER

FARM
 H & H
 D & S
 HELTON'S
 NURSERY
 SEA FO
 HART'S F
 PHILLIP
 FARM PRO

JEFFERSON STORES
 MCCRAY BARBER SHOP #2
 WEST TOWN BEAUTY SHOP
 MECLURE SHOE REPAIR
 HOSKINS DRUG STORE
 WILLIAMS CLEANING & PRESSING
 JEFFERSON THEATER
 JEFFERSON RECREATION HALL

WHEAT SECTION
 WHEAT BARBER SHOP
 WHEAT BEAUTY SHOP
 WHEAT COMMISGARY
 TOWNSITE FOUNTAIN #4

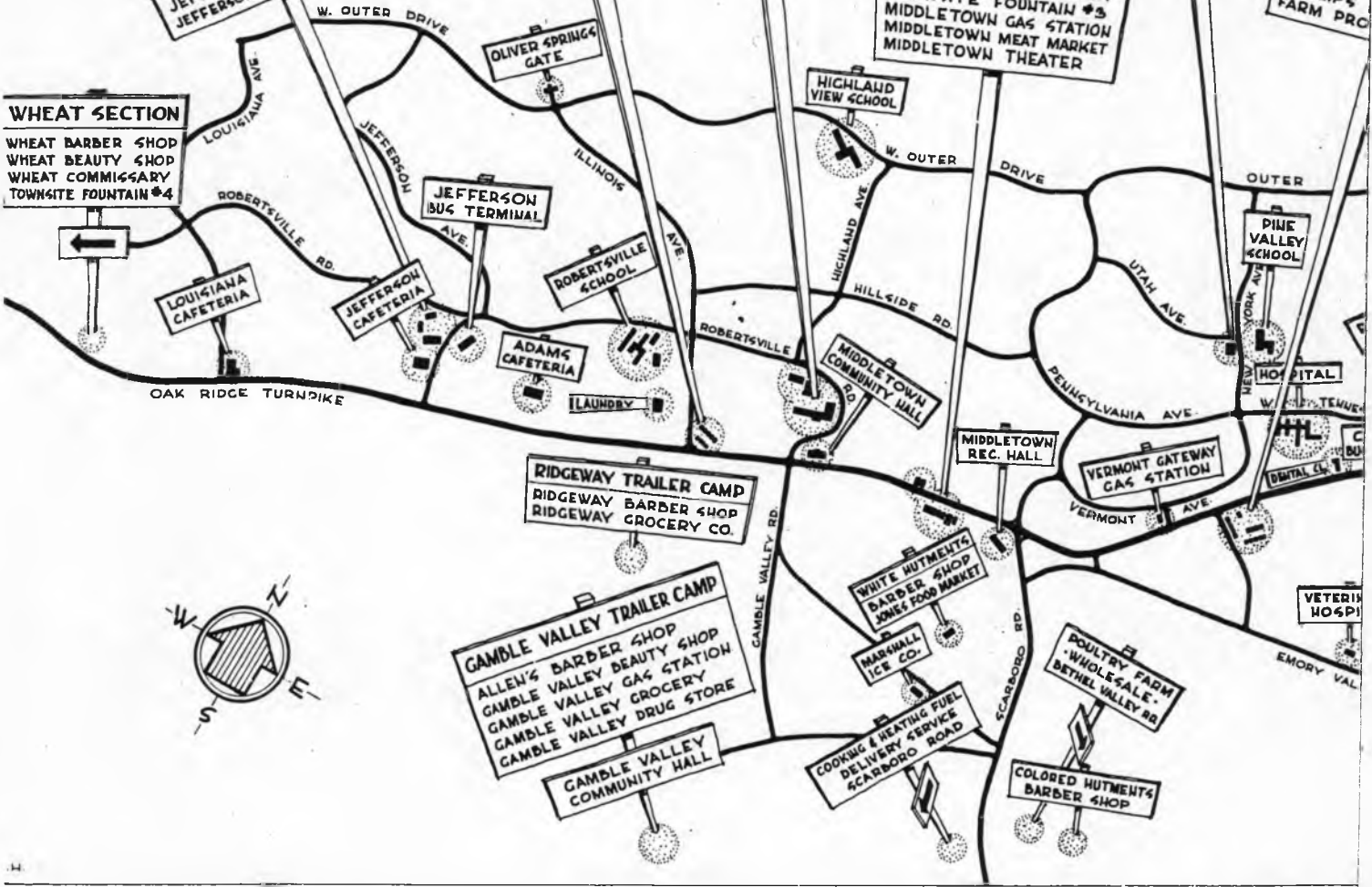

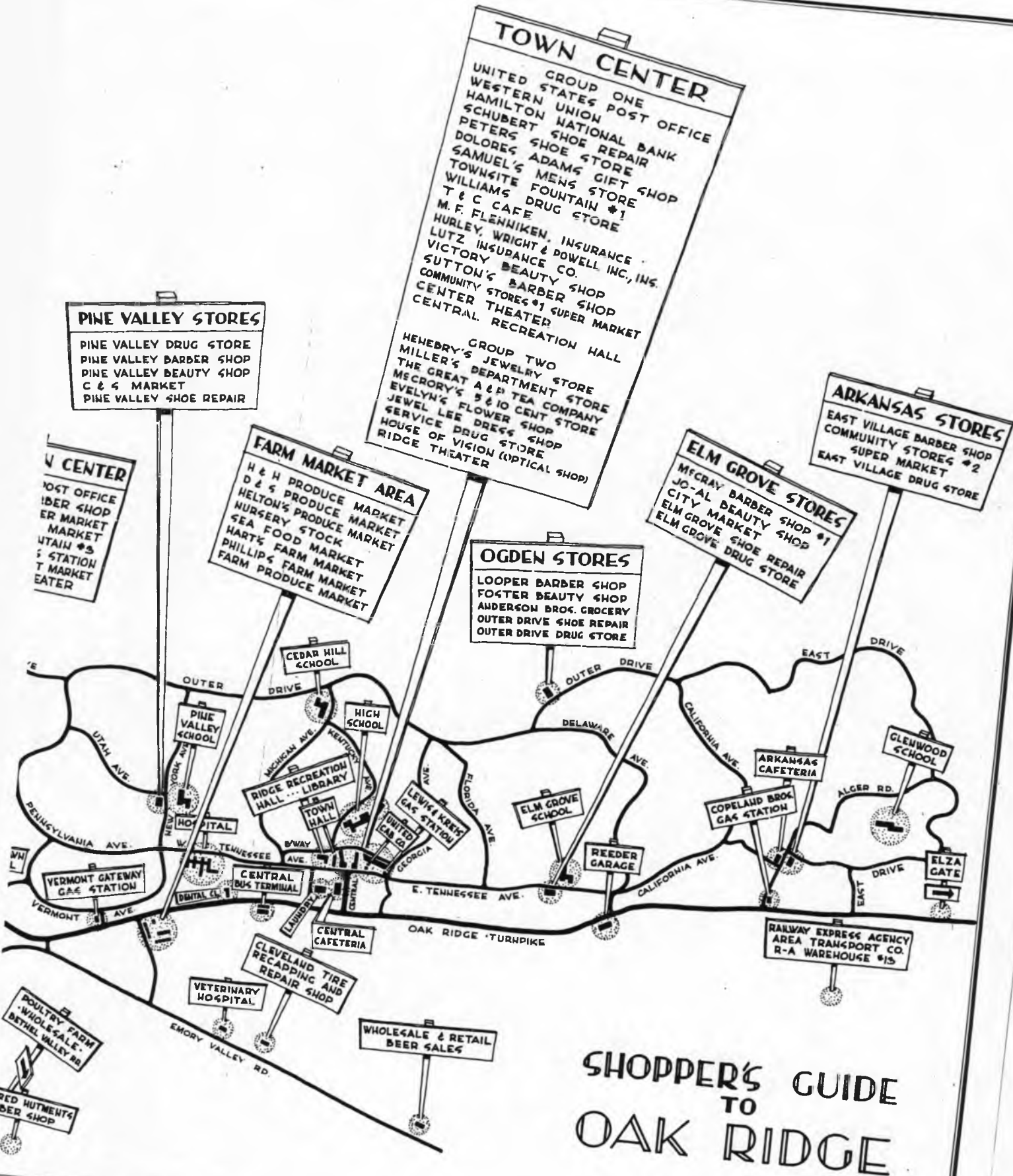

PINE VALLEY STORES
 PINE VALLEY DRUG STORE
 PINE VALLEY BARBER SHOP
 PINE VALLEY BEAUTY SHOP
 C & S MARKET
 PINE VALLEY SHOE REPAIR

TOWN CENTER
 UNITED STATES ONE
 WESTERN UNION
 HAMILTON NATIONAL BANK
 SCHUBERT SHOE REPAIR
 PETERS SHOE STORE
 DOLORES ADAMS STORE
 SAMUEL'S MENS GIFT SHOP
 TOWNKITE STORE
 WILLIAMS DRUG STORE
 T & C CAFE
 M.F. FLENNIKEN, INSURANCE
 HURLEY, WRIGHT & POWELL INC., INS.
 LUTZ INSURANCE CO.
 VICTORY BEAUTY CO.
 SUTTON'S BARBER SHOP
 COMMUNITY STORES #1 SUPER MARKET
 CENTRAL THEATER
 CENTRAL RECREATION HALL

GROUP TWO
 HENEBRY'S JEWELRY STORE
 MILLER'S DEPARTMENT STORE
 THE GREAT A & P TEA COMPANY
 MCCRORY'S 5 & 10 CENT STORE
 EVELYN'S FLOWER SHOP
 JEWEL LEE DRESS SHOP
 SERVICE DRUG STORE
 HOUSE OF VISION (OPTICAL SHOP)
 RIDGE THEATER

FARM MARKET AREA
 H & H PRODUCE MARKET
 D & S PRODUCE MARKET
 HELTON'S PRODUCE MARKET
 NURSERY PRODUCE MARKET
 SEA FOOD STOCK
 HART'S FARM MARKET
 PHILLIPS FARM MARKET
 FARM PRODUCE MARKET

OGDEN STORES
 LOOPER BARBER SHOP
 FOSTER BEAUTY SHOP
 ANDERSON BROS. GROCERY
 OUTER DRIVE SHOE REPAIR
 OUTER DRIVE DRUG STORE

ELM GROVE STORES
 MFCRAY BARBER SHOP #1
 JO-AL BEAUTY SHOP
 CITY MARKET SHOP
 ELM GROVE SHOE REPAIR
 ELM GROVE DRUG STORE

ARKANSAS STORES
 EAST VILLAGE BARBER SHOP
 COMMUNITY STORES #2
 SUPER MARKET
 EAST VILLAGE DRUG STORE

**SHOPPER'S GUIDE
 TO
 OAK RIDGE**

PREPARED BY
 ROANE-ANDERSON COMPANY
 ENGINEERING DEPT. & PUBLIC RELATIONS DEPT.

B-6 ELECTRIC POWER DISTRIBUTION SYSTEM, GEN

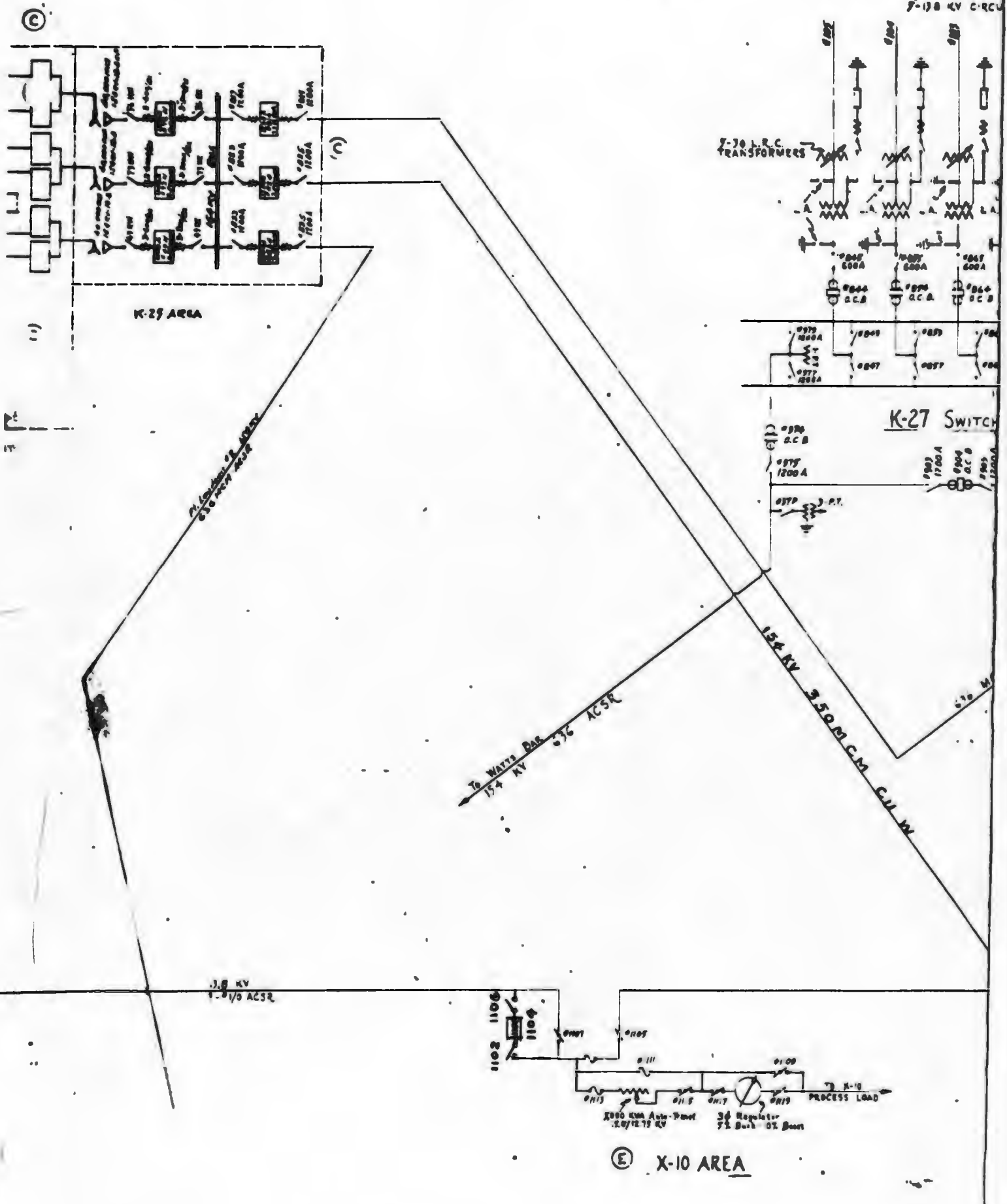

©

K-29 AREA

7-70 J.R.C. TRANSFORMERS

K-27 SWITCH

15.4 KV 3.76 ACSR

15.4 KV 3.50 CM CU AL

3.8 KV 1-3/10 ACSR

© X-10 AREA

B6-1

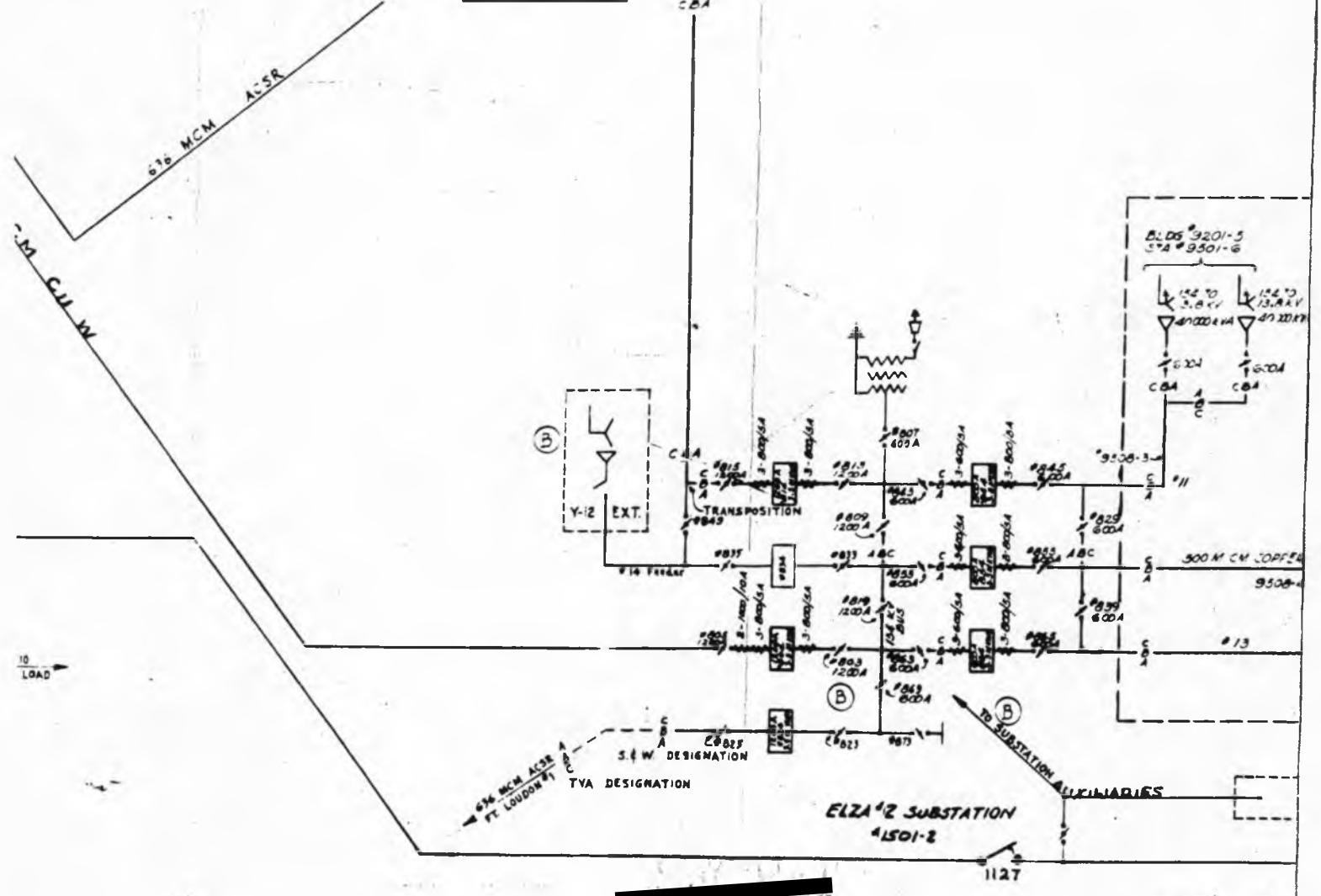
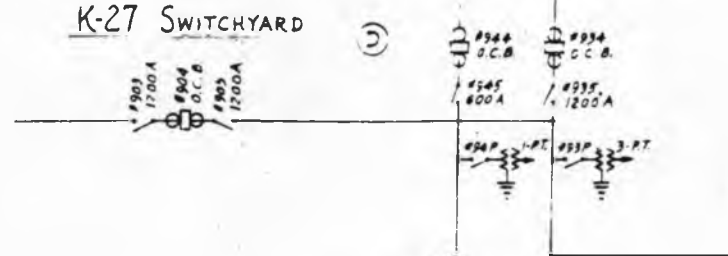
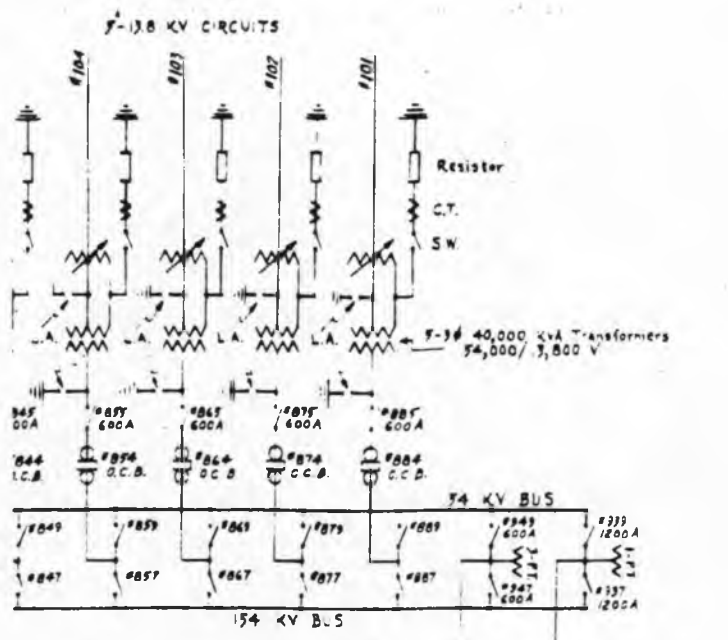

B6-2

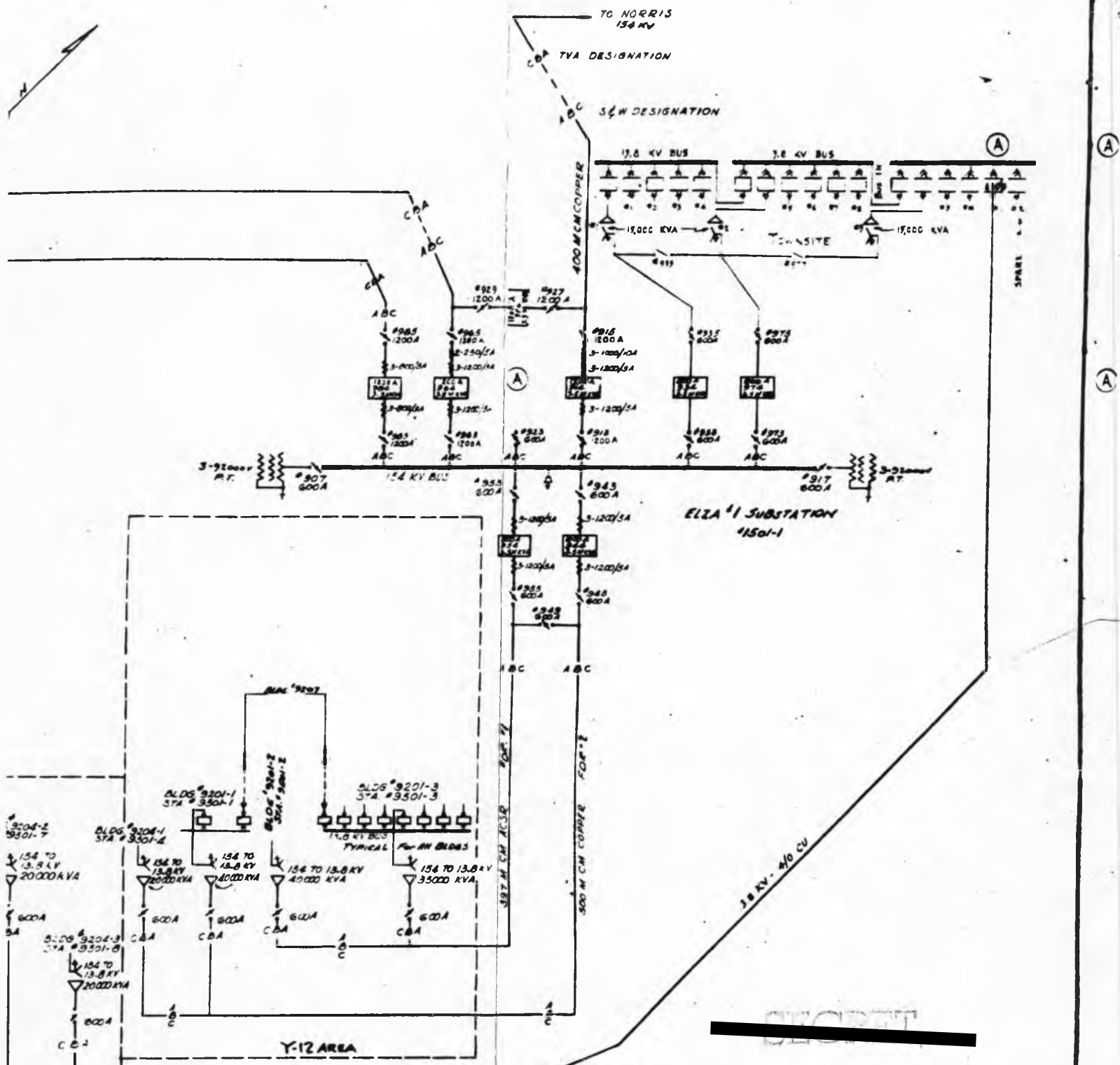

~~SECRET~~

**CLINTON ENGINEER WORKS
ELECTRIC POWER DISTRIBUTION
154KV-13.8KV-60cy.**

DATE	CHANGE	DESCRIPTION	BY	APPROVED
12-2-64	E	X-10 AREA REVISED		
6-4-64	E	X-10 AREA REVISED.		
6-4-64	D	13.8 KV FEEDER FROM ELZA #1 ADDED.	G.J.P.	
6-4-64	D	ELZA #2 SUBSTATION ADDED TO SYSTEM.	G.J.P.	
6-4-64	C	ELZA #3 SUBSTATION REVISED. STEAM PLANT 34 TON HOUSE & R-21 TUB LINE ADDED.	G.J.P.	
6-4-64	B	ELZA #2 SUBSTATION REVISED. 7.5 KV EXT. 3.8 KV FEEDER FROM ELZA #1 ADDED.	G.J.P.	
6-4-64	A	ELZA #1 SUBSTATION REVISED. 4 FEEDERS ADDED. 154 KV TUB LINE HOUSES	G.J.P.	

IN 1 SHEET	SHEET NO. 1	SCALE: N.T.S.
U.S. ENGR. OFFICE - MANHATTAN DIST., KNOXVILLE, TENN.		
DESIGNED BY: <i>Wm. P. Sullivan</i>	APPROVED BY: <i>Wm. P. Sullivan</i>	DATE: 12-2-64
DRAWN BY: <i>Wm. P. Sullivan</i>	FILE NO.: CG-4071-1	TRANSMITTED WITH LETTER OR PROCEDURE

B6-3

B-6a ELECTRIC POWER DISTRIBUTION AND SUPPLY, CEN

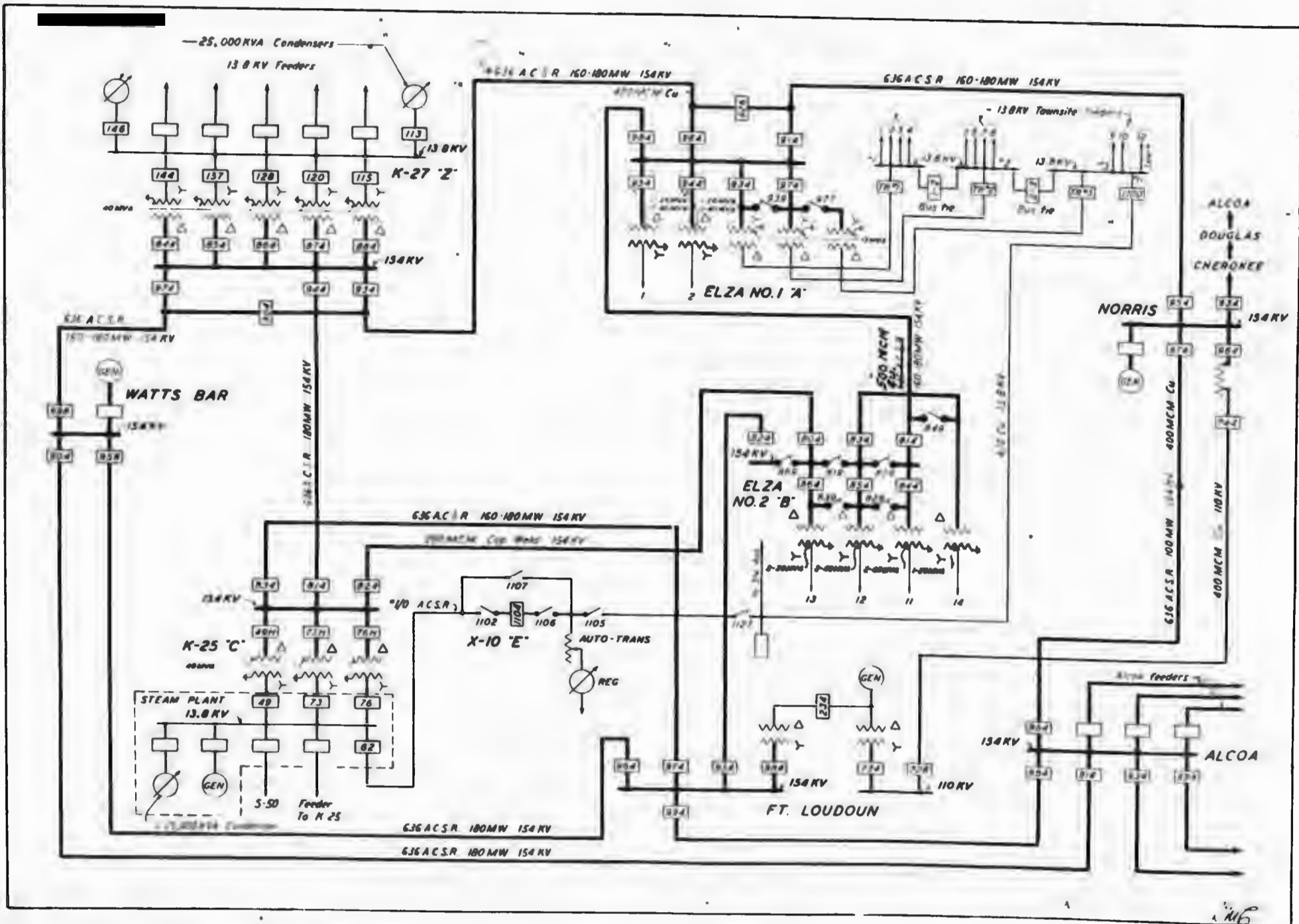

116

B-7 ORIGINAL WATER SUPPLY SYSTEM, OAK RIDGE

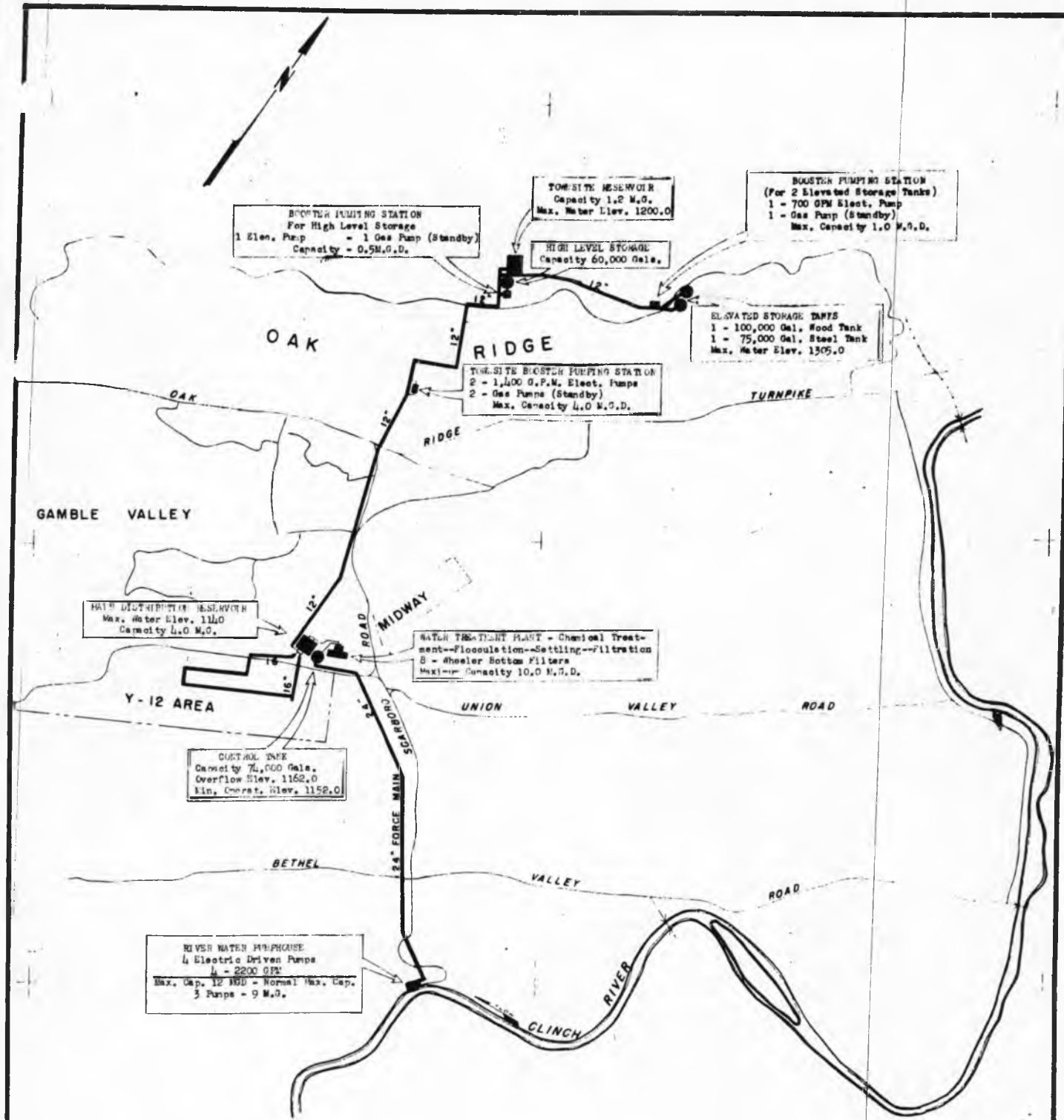

BOOSTER PUMPING STATION
For High Level Storage
1 Elec. Pump - 1 Gas Pump (Standby)
Capacity - 0.5 M.G.D.

TOWN SITE RESERVOIR
Capacity 1.2 M.G.
Max. Water Elev. 1200.0

BOOSTER PUMPING STATION
(For 2 Elevated Storage Tanks)
1 - 700 GPM Elec. Pump
1 - Gas Pump (Standby)
Max. Capacity 1.0 M.G.D.

HIGH LEVEL STORAGE
Capacity 60,000 Gals.

ELEVATED STORAGE TANKS
1 - 100,000 Gal. Wood Tank
1 - 75,000 Gal. Steel Tank
Max. Water Elev. 1305.0

ON-SITE BOOSTER PUMPING STATION
2 - 1,400 G.P.M. Elec. Pumps
2 - Gas Pumps (Standby)
Max. Capacity 4.0 M.G.D.

WATER DISTRIBUTION RESERVOIR
Max. Water Elev. 1110
Capacity 4.0 M.G.

WATER TREATMENT PLANT - Chemical Treatment-Flocculation-Settling-Filtration
8 - Wheel Bottom Filters
Max. Capacity 10.0 M.G.D.

CONTROL TANK
Capacity 74,000 Gals.
Overflow Elev. 1152.0
Elev. Control Elev. 1152.0

RIVER WATER PUMPHOUSE
4 Electric Driven Pumps
4 - 2200 GPM
Max. Cap. 12 MGD - Normal Max. Cap.
3 Pumps - 9 M.G.

WATER SUPPLY
OAK RIDGE, TENN.
IN 3 SHEETS 2400' SHEET NO 2 2400'
U. S. ENGR. OFF. OAK RIDGE, TENN.
ORIGINAL
CG-6012-2

TYPE	DATE	REVISION	REV	CHD	APP

E-8 WATER SUPPLY SYSTEM, OAK RIDGE, NOVEMBER 1944

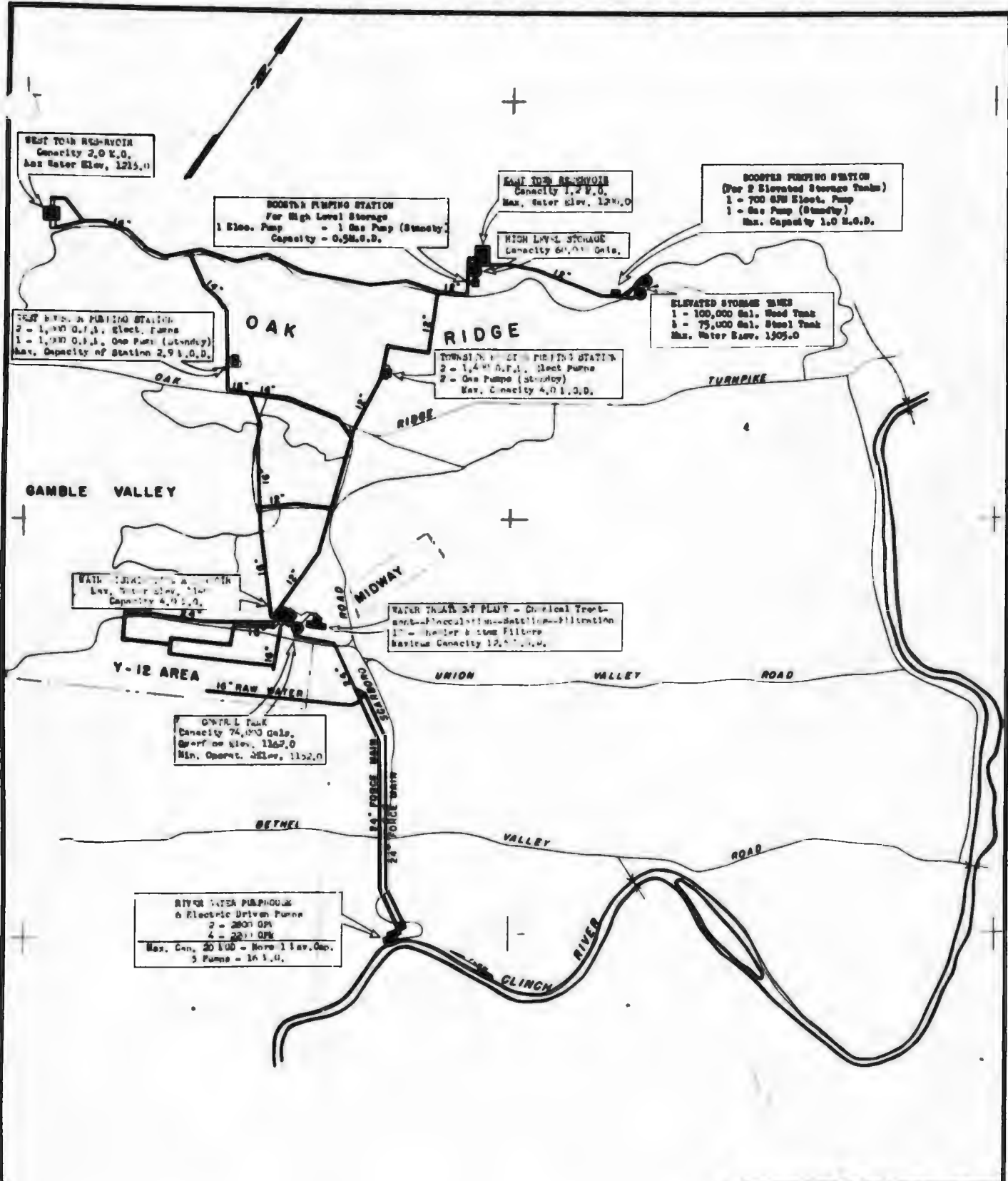

WEST TOWN RESERVOIR
Capacity 2,000,000
Max Water Elev. 1215.0

SOUTH PUMPING STATION
For High Level Storage
1 Elec. Pump - 1 Gas Pump (Standby)
Capacity - 0.5M.G.D.

EAST TOWN RESERVOIR
Capacity 1,200,000
Max. Water Elev. 1240.0

BOOSTER PUMPING STATION
(For 2 Elevated Storage Tanks)
1 - 700 GPM Elec. Pump
1 - Gas Pump (Standby)
Max. Capacity 1.0 M.G.D.

WEST TOWN PUMPING STATION
2 - 1,000 G.P.M. Elec. Pumps
1 - 1,000 G.P.M. Gas Pump (Standby)
Max. Capacity of Station 2,900,000

HIGH LEVEL STORAGE
Capacity 60,000 Gals.

ELEVATED STORAGE TANKS
1 - 100,000 Gal. Steel Tank
5 - 75,000 Gal. Steel Tank
Max. Water Elev. 1305.0

TOWNSHIP WATER PUMPING STATION
2 - 1,400 G.P.M. Elec. Pumps
2 - Gas Pumps (Standby)
Max. Capacity 4,000,000

GAMBLE VALLEY

WATER TREATMENT PLANT
Capacity 12,000,000
Max. Oper. Elev. 1152.0

WATER TREATMENT PLANT - Chemical Treatment
and physical treatment - Filtration
17" - Chamber & Sand Filters
Basic Capacity 12,000,000

Y-12 AREA
16" RAW WATER

CENTRAL TANK
Capacity 74,000 Gals.
Max. Oper. Elev. 1152.0

RIVER WATER INTAKE
6 Electric Driven Pumps
2 - 2800 GPM
4 - 2200 GPM
Max. Cap. 20,000 - More 1 Elev. Cap.
3 Pumps - 16 I.D.

WATER SUPPLY
OAK RIDGE, TENN

IN 3 SHEETS
SHEET NO 1

U.S. ENGR OFF. OAK RIDGE, TENN.
NOV. 1944

TYPE	DATE	REVISION	REV	CHK	APP	OR BY	TR BY	DATE

CG-6012-1

B-9 WATER SUPPLY SYSTEM, OAK RIDGE, 31 DECEMBER 1946

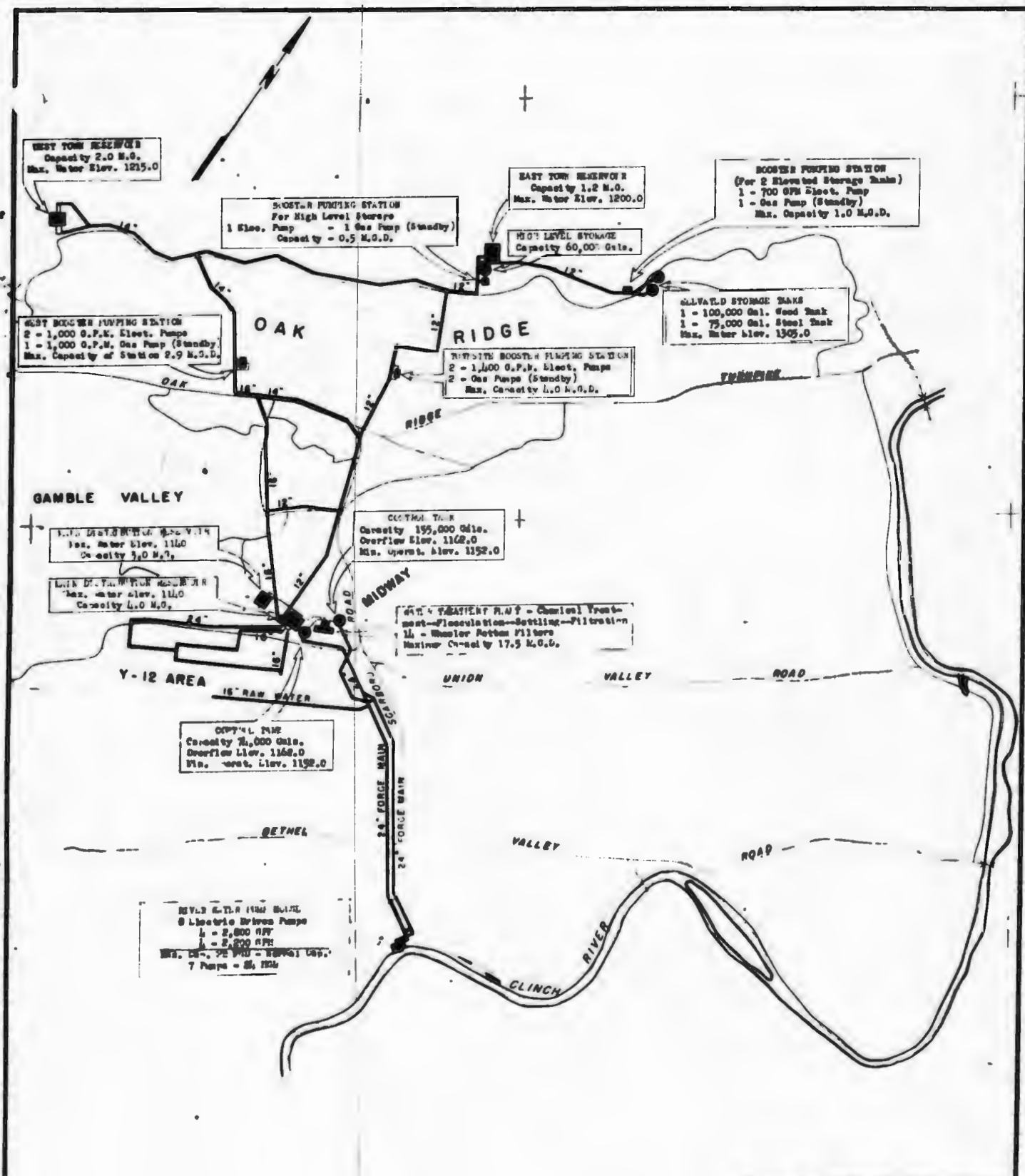

WEST TOWN RESERVOIR
Capacity 2.0 M.G.
Max. Water Elev. 1215.0

WEST-ER PUMPING STATION
For High Level Storage
1 Elec. Pump - 1 Gas Pump (Standby)
Capacity - 0.5 M.G.D.

EAST TOWN RESERVOIR
Capacity 1.2 M.G.
Max. Water Elev. 1200.0

BOOSTER PUMPING STATION
(For 2 Elevated Storage Tanks)
1 - 700 GPM Elect. Pump
1 - Gas Pump (Standby)
Max. Capacity 1.0 M.G.D.

WEST BOOSTER PUMPING STATION
2 - 1,000 G.P.M. Elect. Pumps
1 - 1,000 G.P.M. Gas Pump (Standby)
Max. Capacity of Station 2.9 M.G.D.

HIGH LEVEL STORAGE
Capacity 60,000 Gals.

CALVALD STORAGE TANKS
1 - 100,000 Gal. Wood Tank
1 - 75,000 Gal. Steel Tank
Max. Water Elev. 1305.0

TRIP-SITE BOOSTER PUMPING STATION
2 - 1,400 G.P.M. Elect. Pumps
2 - Gas Pumps (Standby)
Max. Capacity 4.0 M.G.D.

WEST BOOSTER PUMPING STATION
Max. Water Elev. 1160
Capacity 3.0 M.G.

CENTRAL TANK
Capacity 195,000 Gals.
Overflow Elev. 1162.0
Min. Operat. Elev. 1152.0

WEST BOOSTER PUMPING STATION
Max. Water Elev. 1140
Capacity 4.0 M.G.

WATER TREATMENT PLANT - Chemical Treatment - Flocculation - Settling - Filtration
14 - Wheel Bottom Filters
Maximum Capacity 17.5 M.G.D.

WEST TOWN RESERVOIR
Capacity 2,000 Gals.
Overflow Elev. 1162.0
Min. Operat. Elev. 1152.0

SEVERAL ELECTRIC DRIVEN PUMPS
4 - 2,000 GPM
4 - 2,000 GPM
7 Pumps - 21, 1926

WATER SUPPLY
OAK RIDGE, TENN.
IN 3 SHEETS SHEET NO 3
1" = 100' 2400'
U.S. ENGR OFF. OAK RIDGE, TENN.
EXISTING
31 DEC. 1940
CG-6012-3

TYPE	DATE	REVISION	BY	CHKD	APP'D	UR BY

B-10 ACCESS ROADS, CEM, NOVEMBER 1944

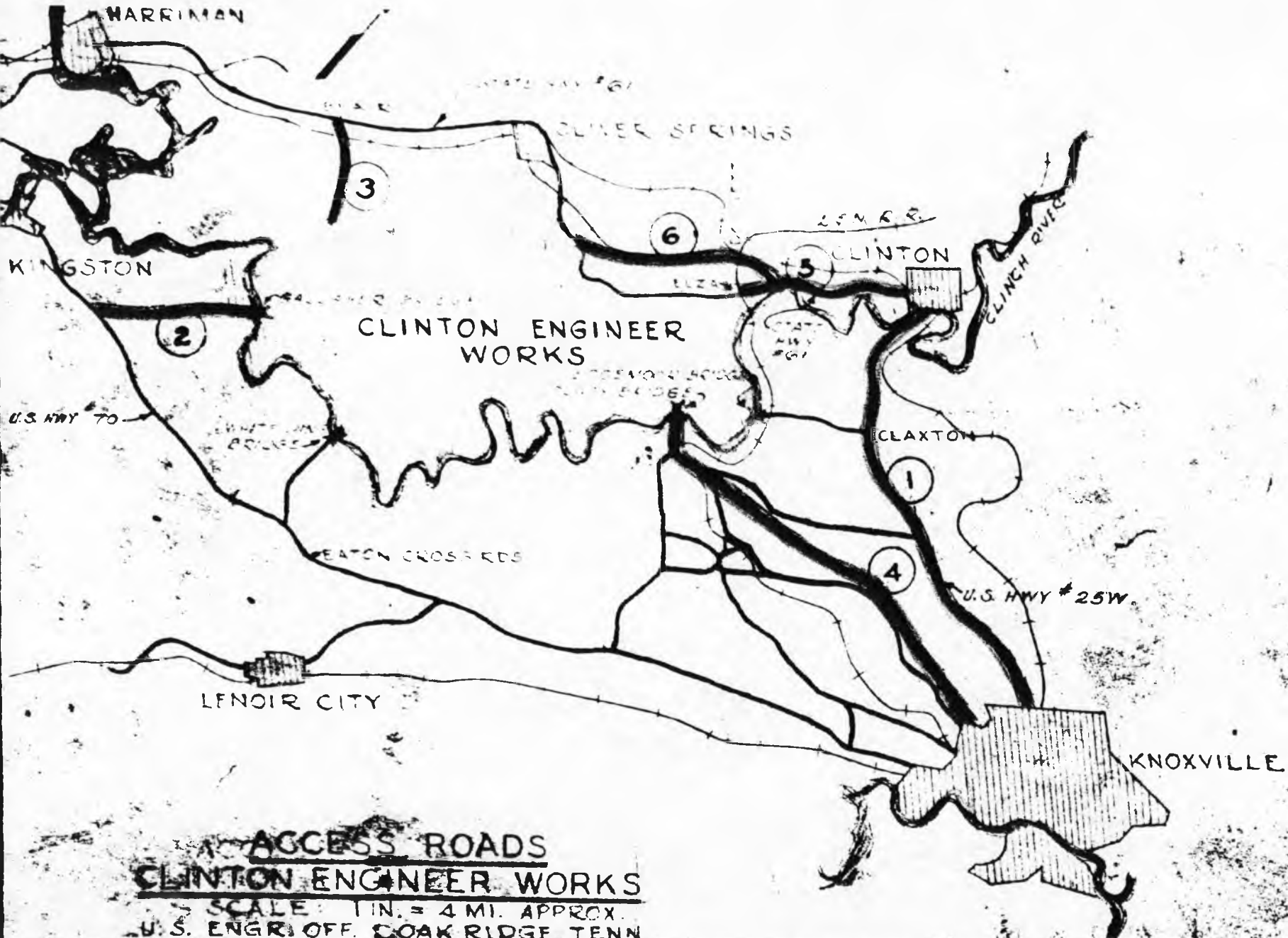

ACCESS ROADS
CLINTON ENGINEER WORKS
 SCALE: 1 IN. = 4 MI. APPROX.
 U.S. ENGR. OFF. COAK RIDGE, TENN.
 NOV. 1954

B-11 CENTRAL RAILROAD SYSTEM, CSX

E 55 000

E 60 000

E 65 000

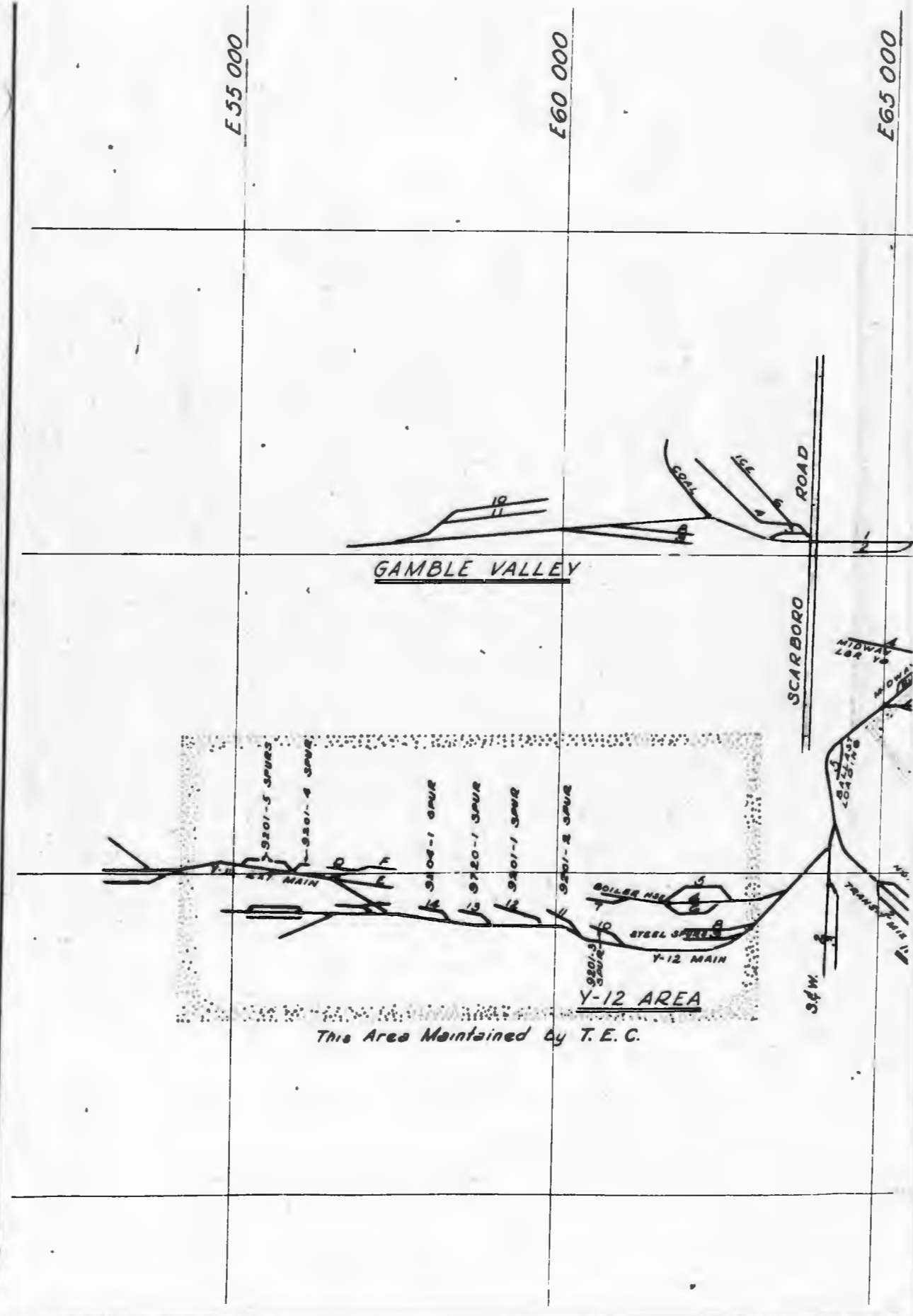

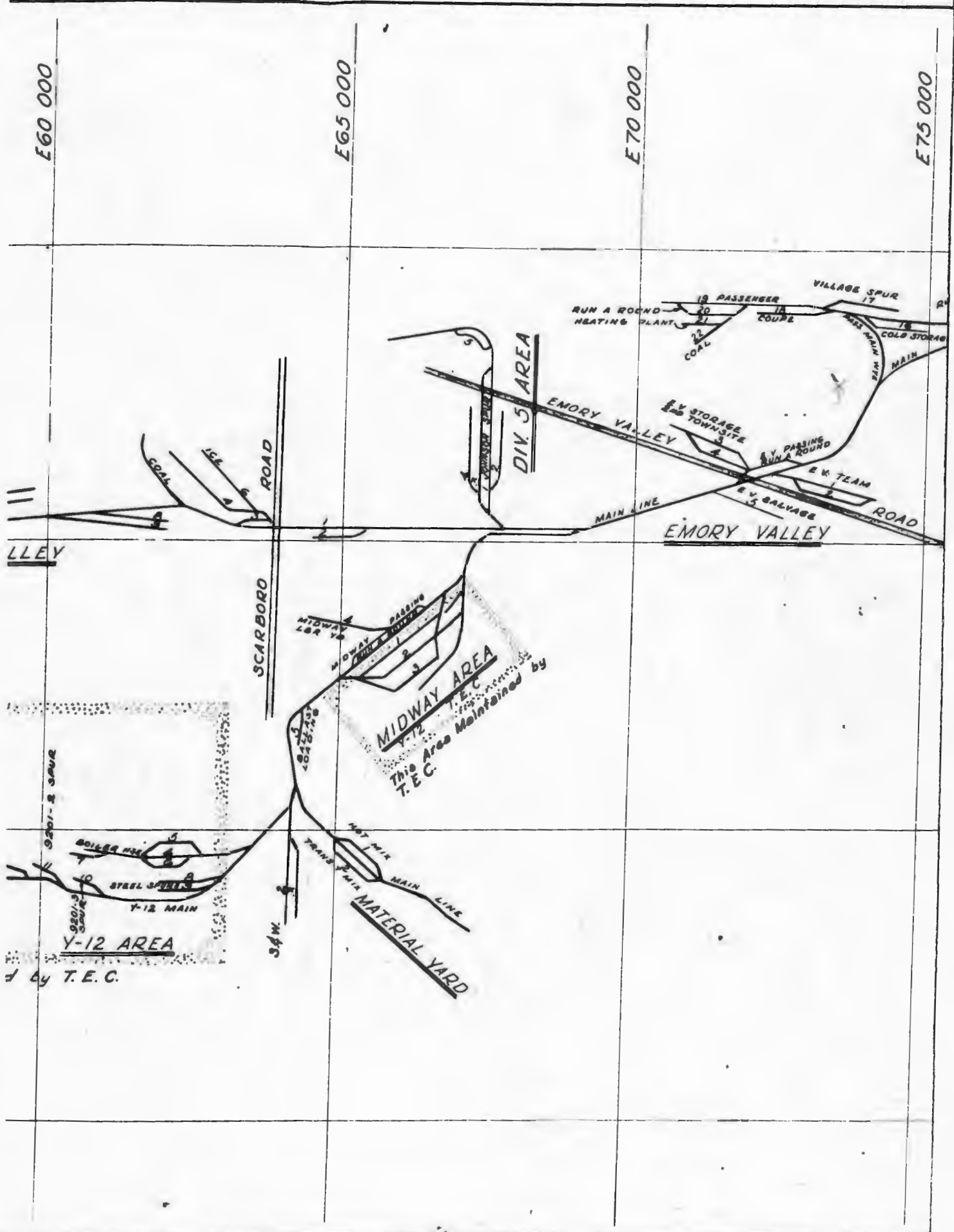

E60 000

E65 000

E70 000

E75 000

LLEY

SCARBORO ROAD

MIDWAY AREA
Y-12
T.E.C.
This Area Maintained by
T.E.C.

Y-12 AREA

d by T.E.C.

MATERIAL YARD

EMORY VALLEY

B-11-2

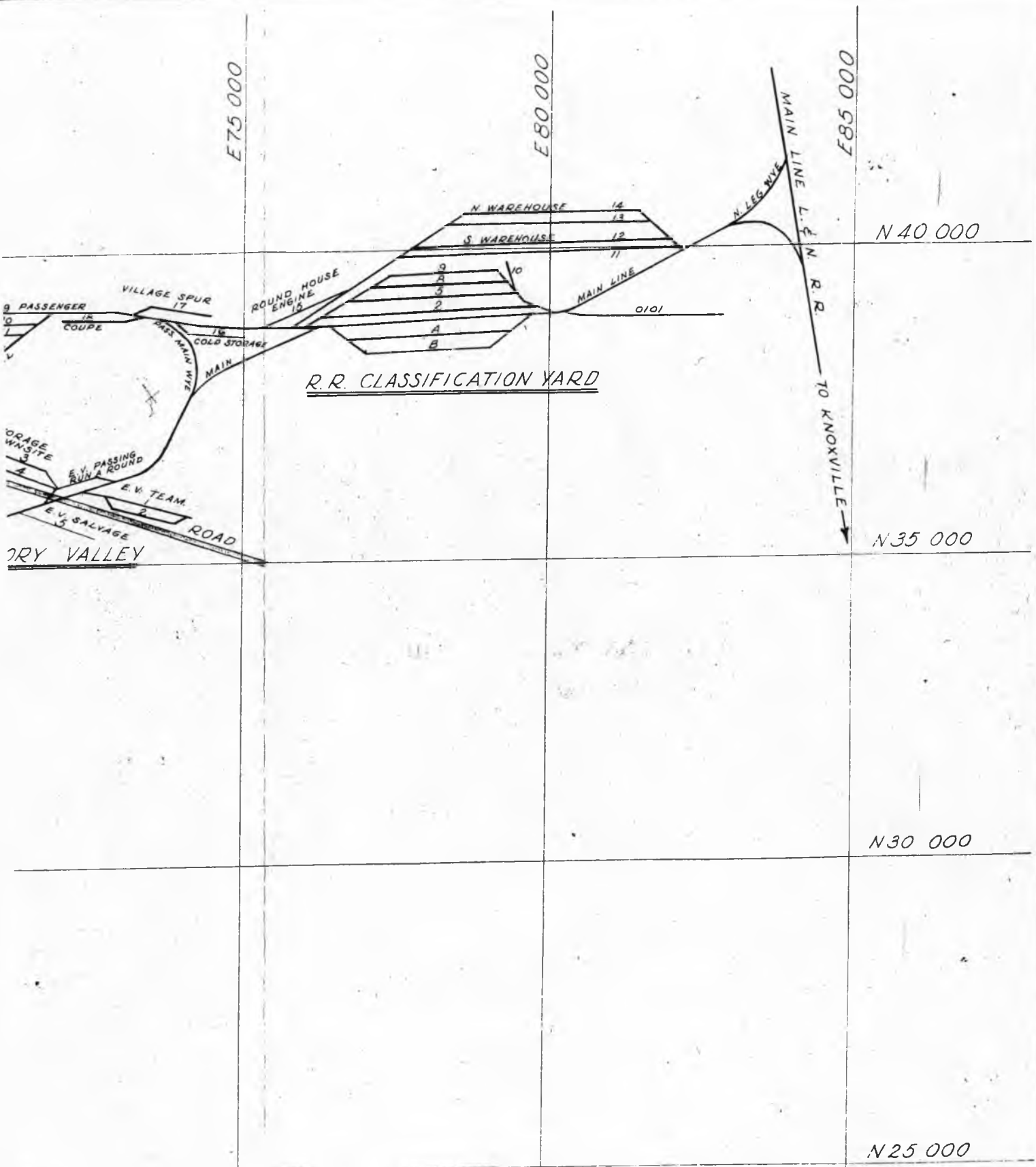

CLINTON ENGINEER WORKS
RAILROAD SYSTEM
L. & N. CONNECTION

B-12 BUS TRANSPORTATION MAP, OFF-AREA,

FEBRUARY 1944 TO JANUARY 1945

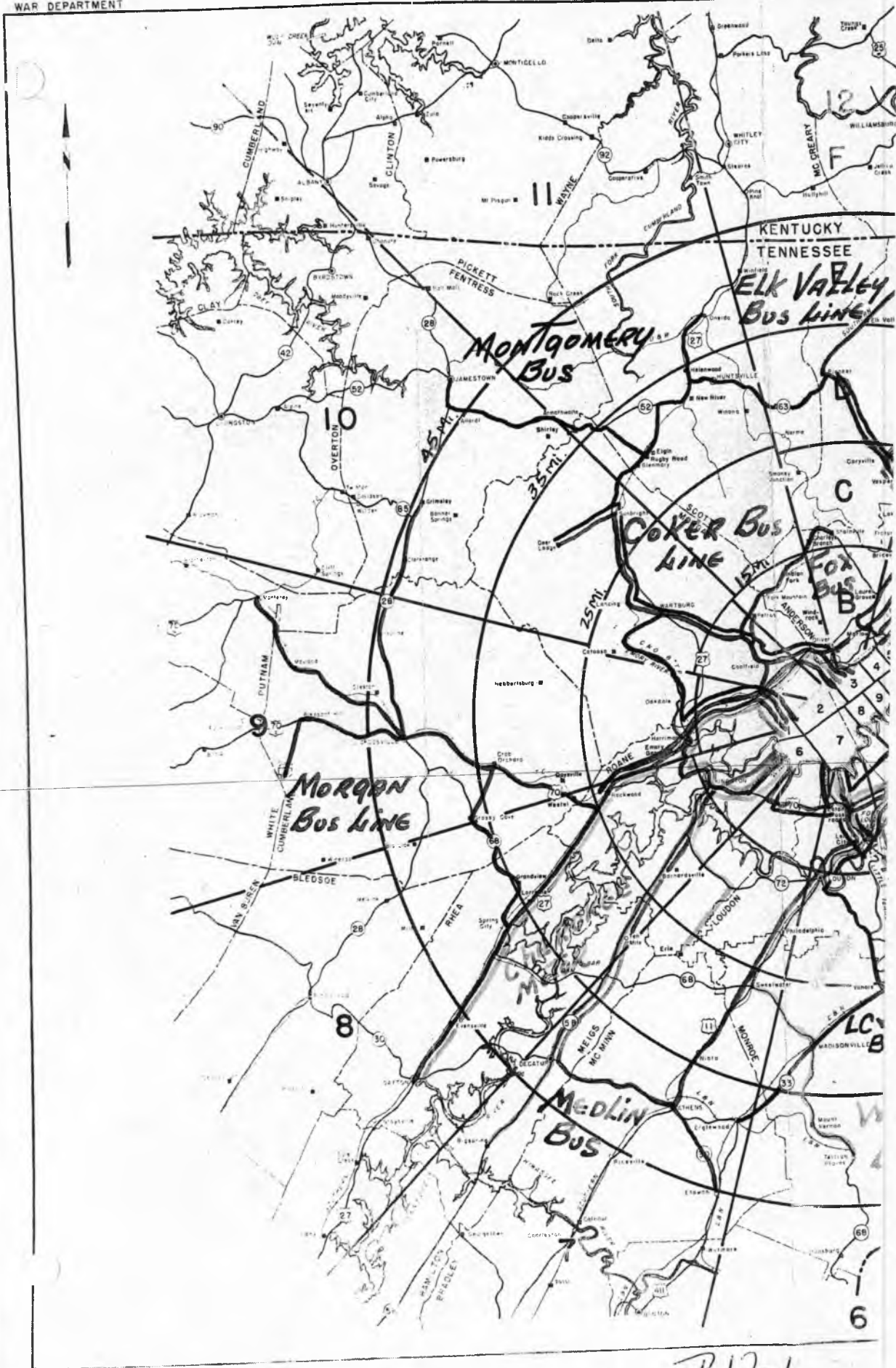

C.E.W. BUS AUTHORITY
FEBRUARY 1944 TO JANUARY 1945

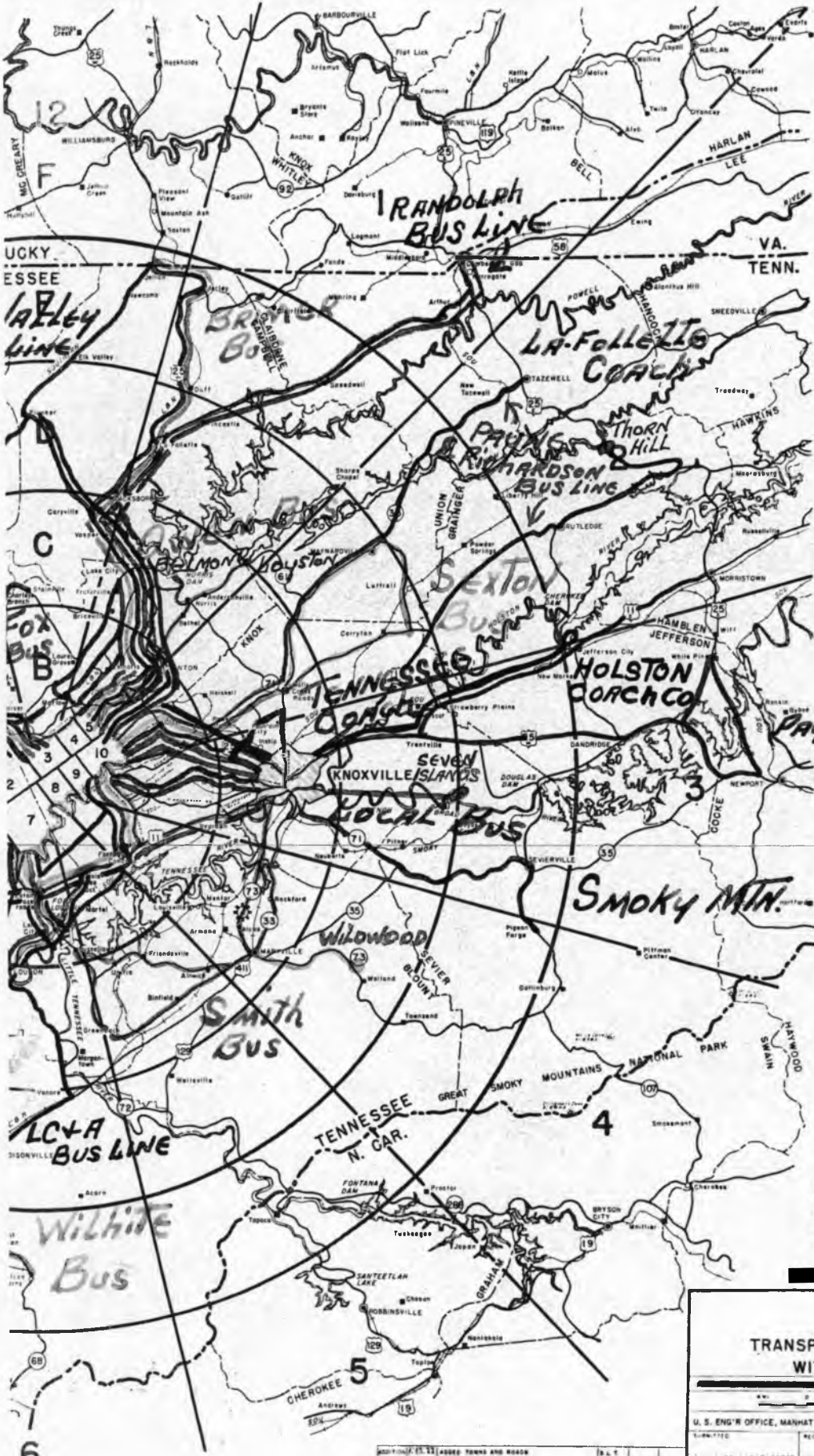

PAYNE & RICHARDSON
Bus Line

This document contains information affecting the national defense of the United States within the meaning of the Espionage Act, 50 USC 31 and 32, as amended, its transmission or the revelation of its contents in any manner to an unauthorized person is prohibited by law.

TRANSPORTATION MAP
WITH ZONES

U. S. ENG'G OFFICE, MANHATTAN DIST., KNOXVILLE, TENN.

B12-2

B-12a BUS TRANSPORTATION MAP, OFF-AREA,
AUGUST 1946
FEBRUARY 1945 TO ~~DECEMBER 1945~~

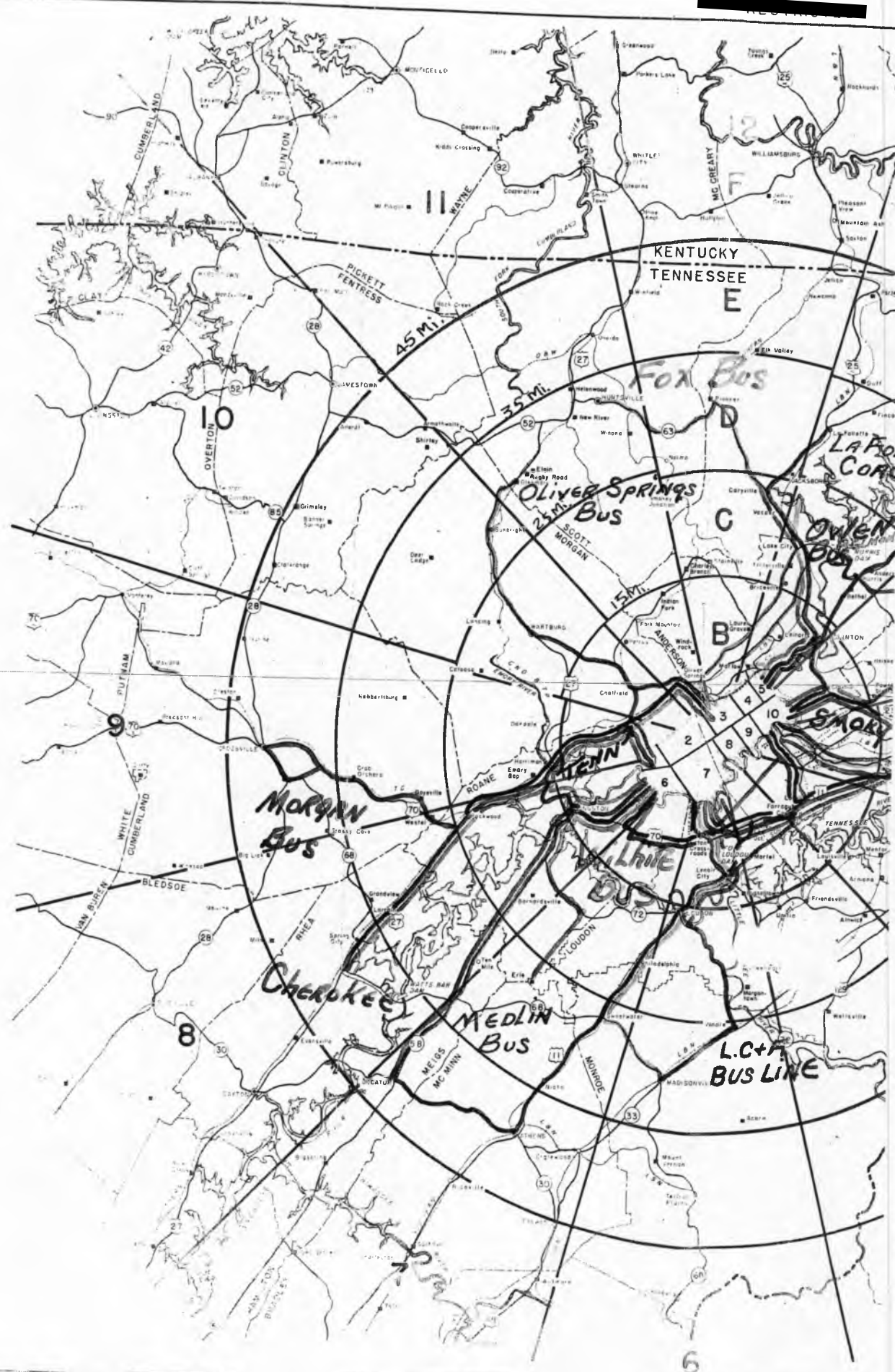

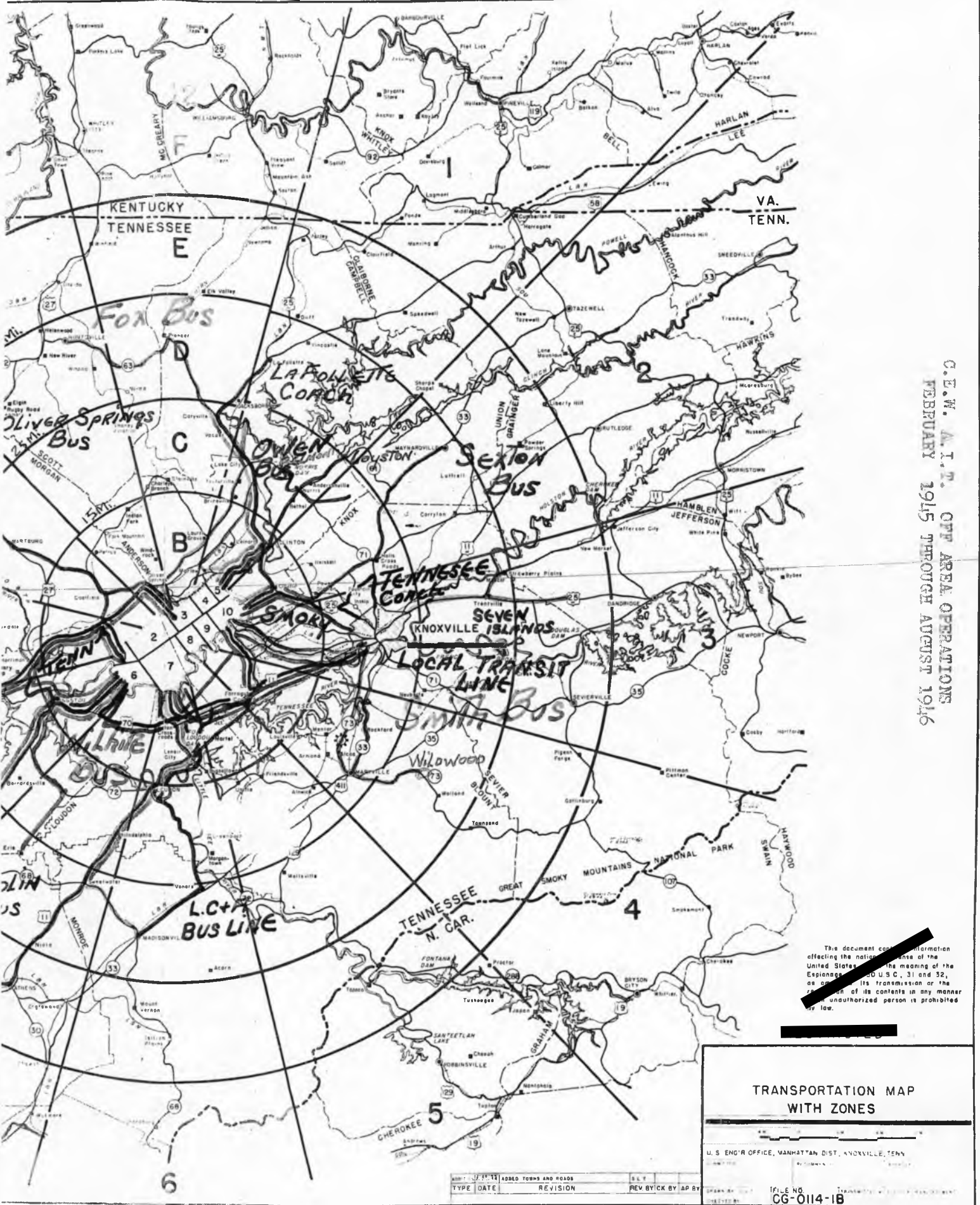

C.E.W. A.I.T. OFF AREA OPERATIONS
 FEBRUARY 1945 THROUGH AUGUST 1946

This document contains information
 affecting the national defense of the
 United States within the meaning of the
 Espionage Laws, U.S.C., 31 and 32,
 as amended; its transmission or the
 revelation of its contents in any manner
 unauthorized by law is prohibited
 by law.

**TRANSPORTATION MAP
WITH ZONES**

U.S. ENGR. OFFICE, MANHATTAN DIST., KNOXVILLE, TENN.
 SCALE: 1" = 10 MILES
 DATE: 1946
 FILE NO. CG-0114-1B

NO.	DATE	REVISION	REV BY	CHK BY

B-12a
2

B-13 ROAD SYSTEM, CSM, 29 MAY 1945



POPLAR CREEK GATE

①
P-26 AREA INCLUDING J.A. JONES CAMPS & BARRACKS AND WHEAT COLONY

GALLAHER GATE

WHITE WING GATE

SOANE COUNTY
ANDERSON COUNTY

LOUDON COUNTY
KNOX COUNTY

3 MILES

1.8 MILES

3.9 MILES

8.4 MILES

2.5 MILES

3.0 MILES

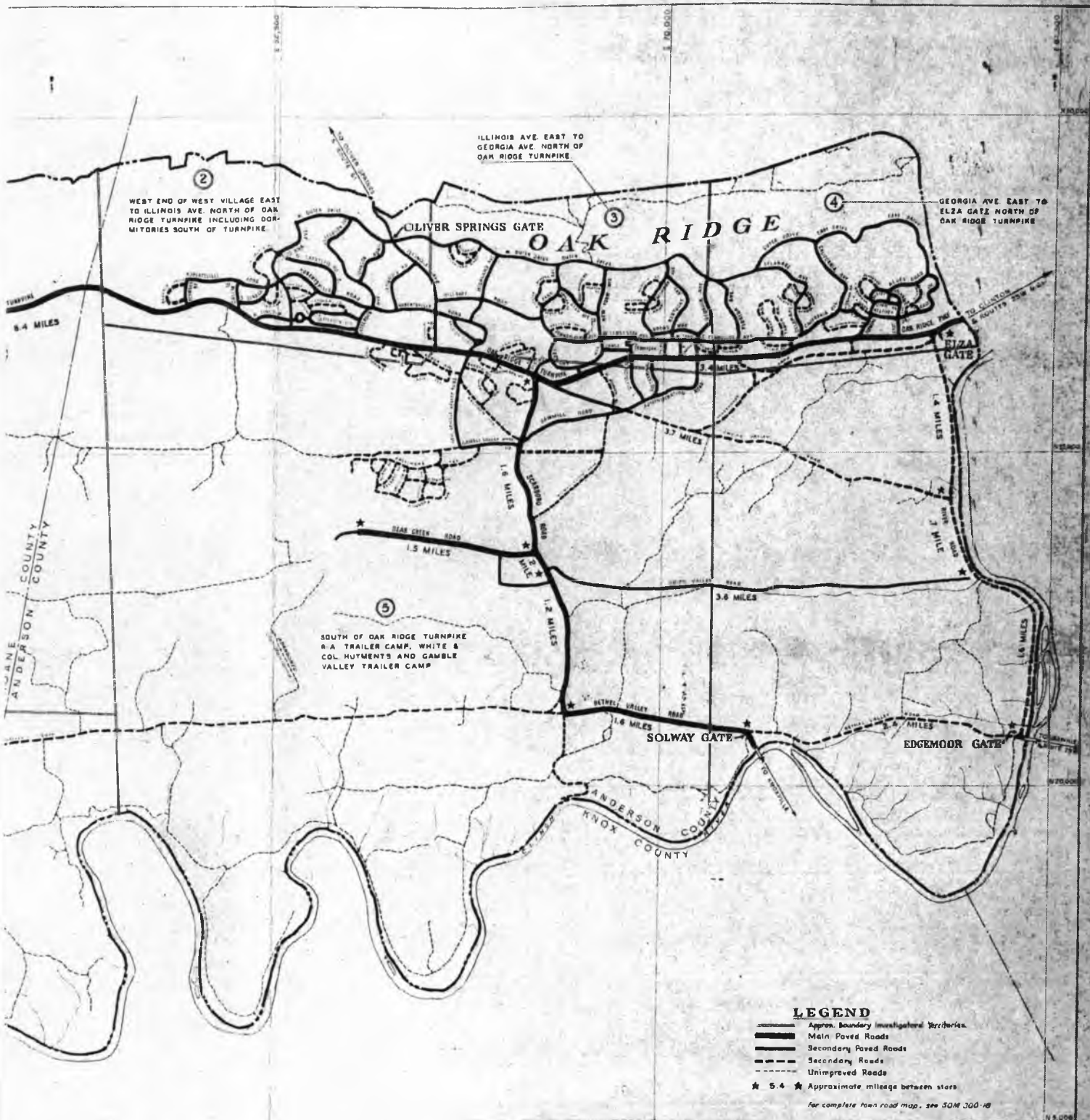

LEGEND

- Approx. Boundary Investigated Territories.
 - Main Paved Roads
 - Secondary Paved Roads
 - Secondary Roads
 - Unimproved Roads
 - ★ 5.4 ★ Approximate mileage between stores
- for complete road map, see SQM 300-18

ROANE-ANDERSON COMPANY			
OAK RIDGE — TENNESSEE			
CLINTON ENGINEER WORKS			
[Redacted]			
SCALE — [Scale Bar]		APPROVED FOR DISTRICT ENGINEER	
DATE 5-29-48	BY [Signature]	DATE [Blank]	BY [Blank]
DATE [Blank]	REVISION [Blank]	CHECKED [Blank]	APPROVED [Blank]
APPROVED BY [Blank]	DATE [Blank]	DRAWN M.S.H.	CHECKED [Blank]
		APPROVED [Blank]	DRAWING NUMBER [Blank]

B-13

B-13a ROAD SYSTEM, CEN, 1 APRIL 1946

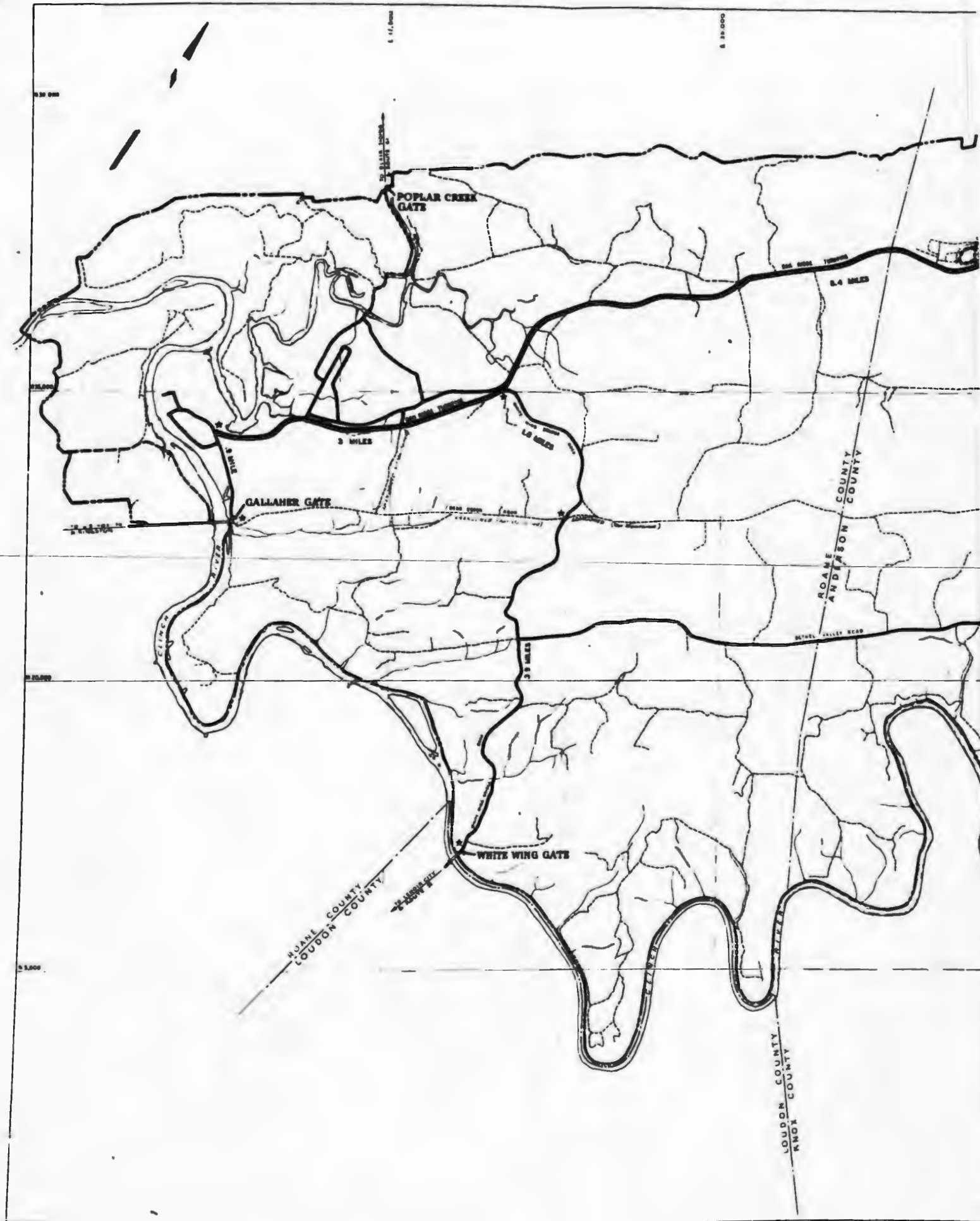

B13a-1

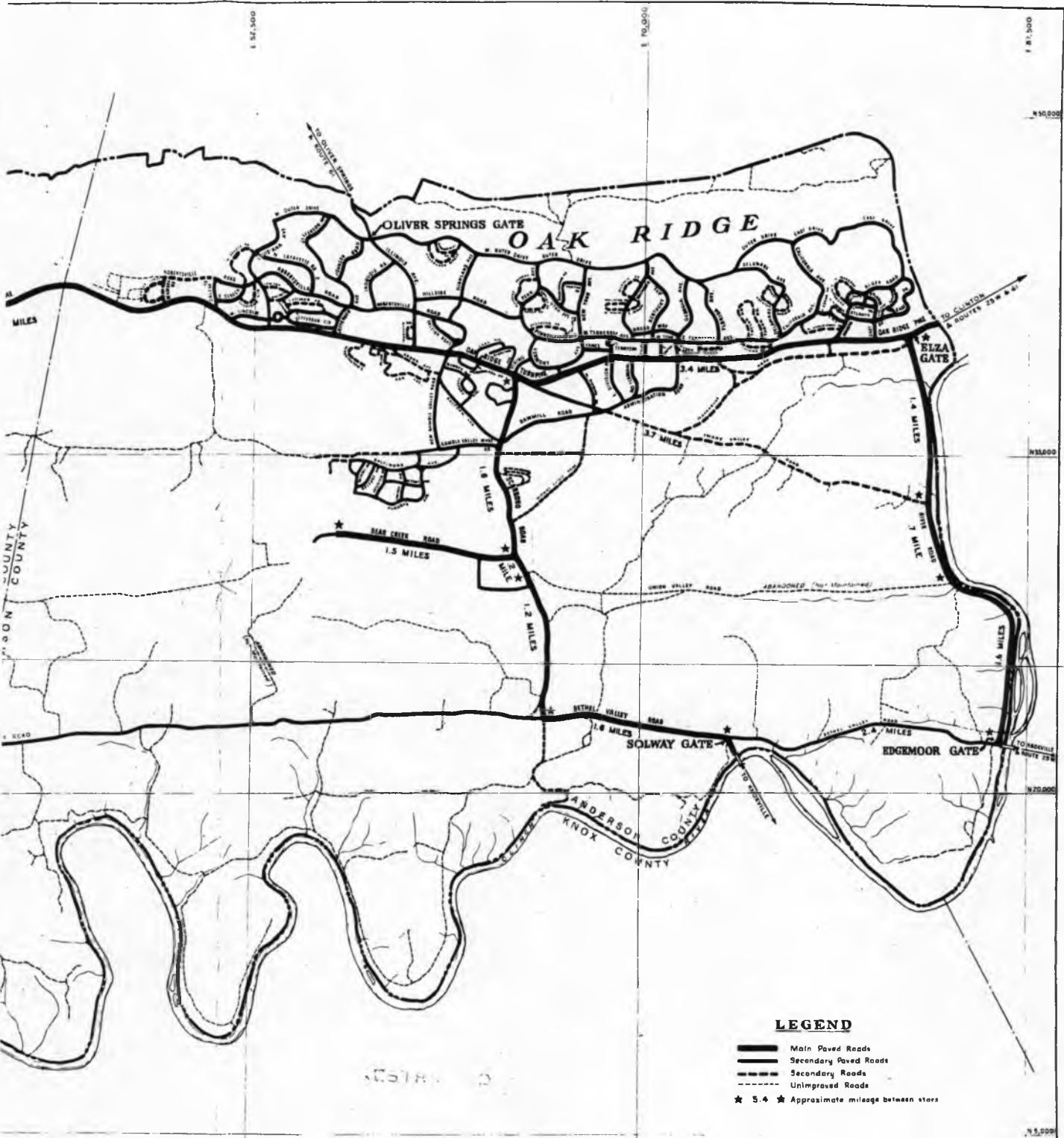

LEGEND

- Main Paved Roads
- - - Secondary Paved Roads
- - - Secondary Roads
- - - Unimproved Roads
- ★ 5.4 ★ Approximate mileage between stars

					ROANE-ANDERSON COMPANY OAK RIDGE - TENNESSEE	
					CLINTON ENGINEER WORKS ROAD MAP	
					SCALE	APPROVED FOR DISTRICT ENGINEER
					DATE	BY <i>C. D. [Signature]</i>
					DRAWN	CHECKED
					APPROVED	DRAWING NUMBER
					M. S. H.	ES 40

APPROVED BY _____ DATE _____

B-13a
2

B-13b ROAD SYSTEM, CEN, 31 DECEMBER 1946

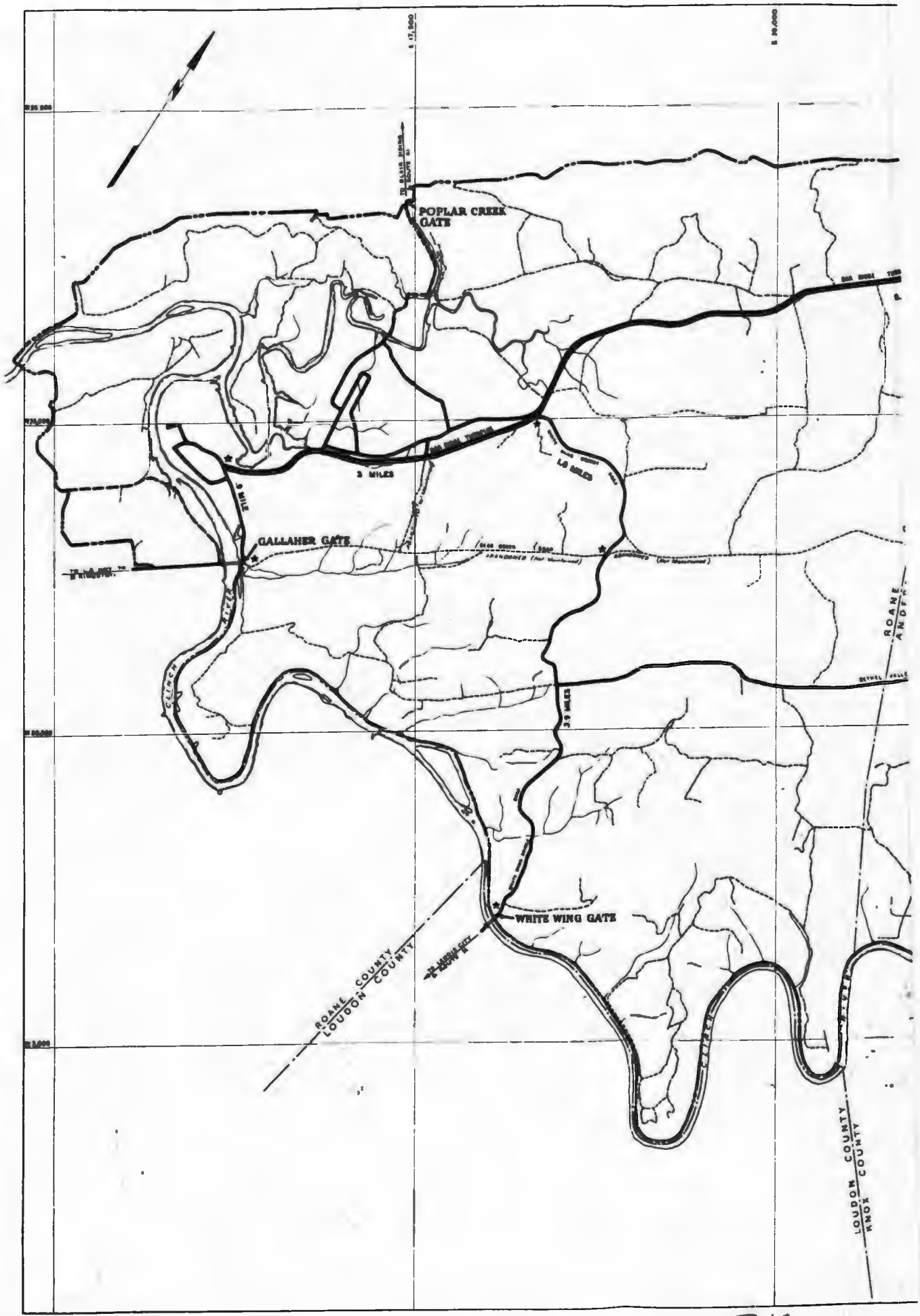

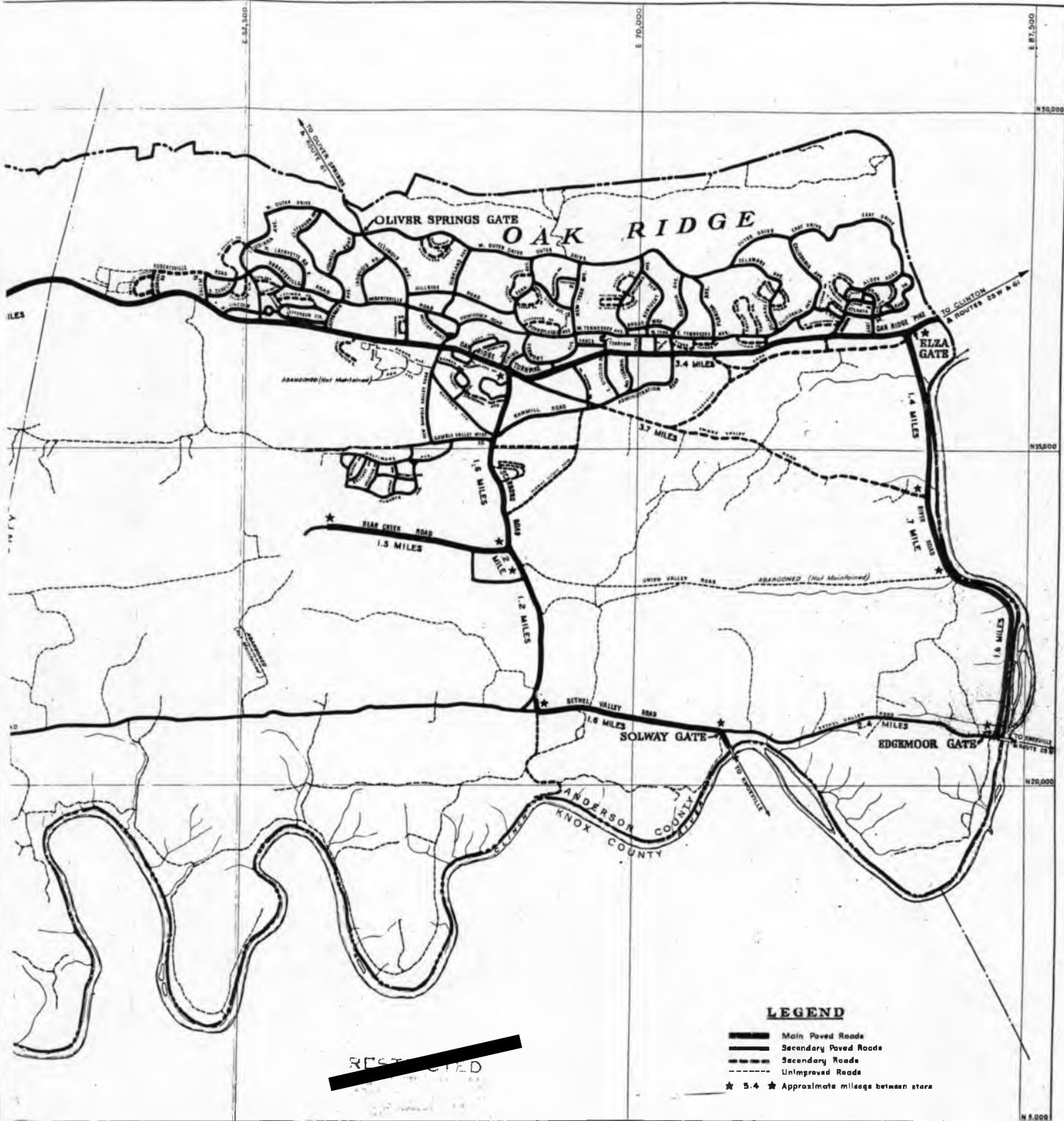

RESTRICTED

LEGEND

- Main Paved Road
- Secondary Paved Road
- Secondary Road
- - - - - Unimproved Road
- ★ 5.4 ★ Approximate mileages between stars

				ROANE-ANDERSON COMPANY	
				OAK RIDGE - TENNESSEE	
				CLINTON ENGINEER WORKS	
				ROAD MAP	
12-31-46	Added Providence Sta. Springs, An- cher Sta. Man Sta. Sta. Sta. abandoned.				
4-1-46	River Rd, Bethel Valley, Gumble Valley Trailer Camp roads surfaced, Union Valley and portion Bear Creek roads abandoned				
5-29-45	Mt Vernon Church Road and portion of Bear Creek Rd. abandoned	R.R.			
DATE	REVISION	DRAWN	CHECKED	APPROVED	APPROVED FOR DISTRICT ENGINEER
					BY <i>E. C. Wood</i>
				SCALE: 1" = 2400'	DATE: MAY 16, 1945
		DRAWN M.S.H.	CHECKED R.A.R.	APPROVED J.S. COOPER	DRAWING NUMBER ES 40

APPROVED BY _____ DATE _____
U.S. SAFETY DEPT.

RESTRICTED

B-136

R136-2

B-14 SEWERAGE SYSTEM, OAK RIDGE, 31 DECEMBER 1946

E 10,000

F 1:2,500

5841 HOUSING UNITS



POPLAR CREEK WATER SHED

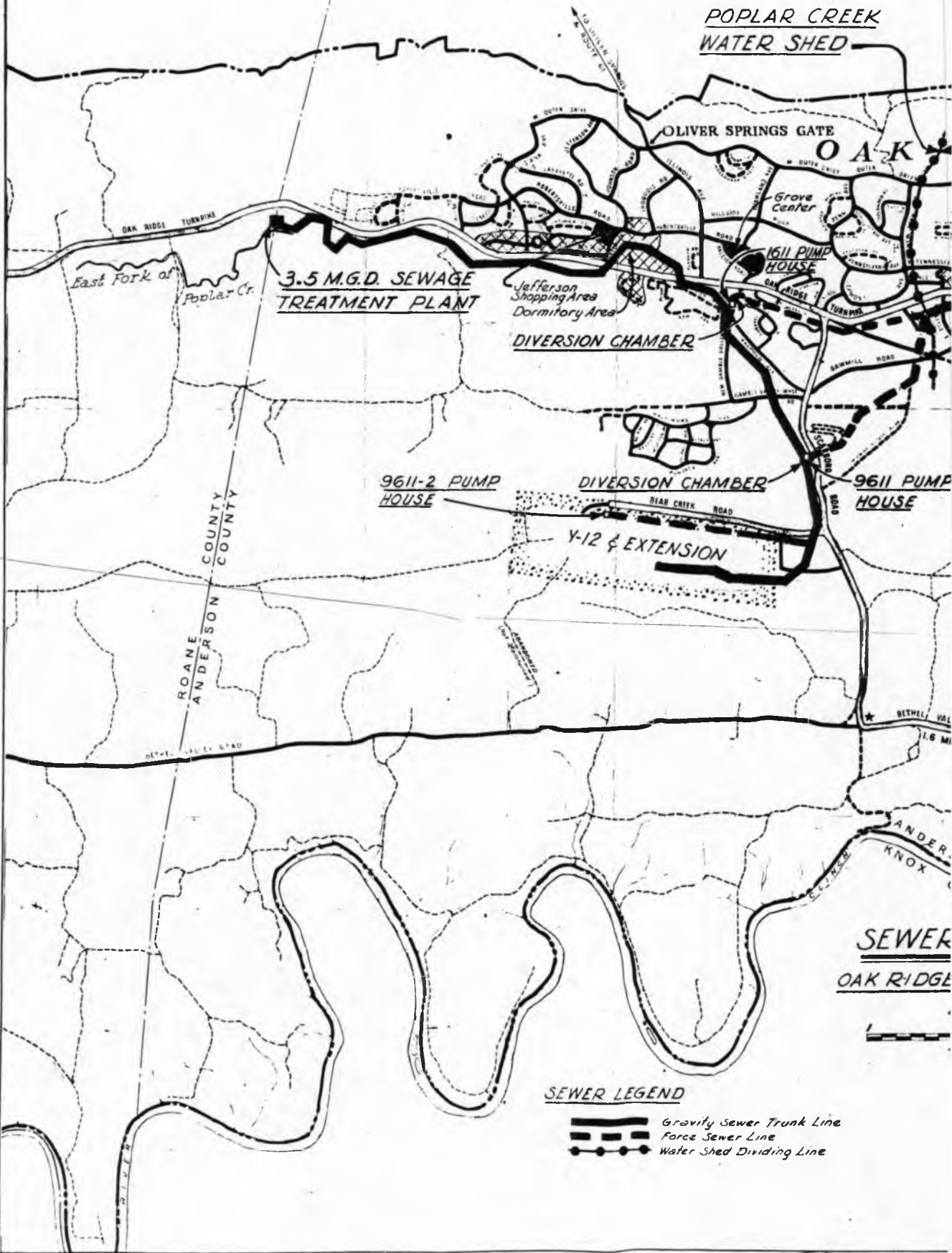

3.5 M.G.D. SEWAGE TREATMENT PLANT

DIVERSION CHAMBER

9611-2 PUMP HOUSE



DIVERSION CHAMBER

9611 PUMP HOUSE

Y-12 & EXTENSION

SEWER OAK RIDGE

SEWER LEGEND

-  Gravity Sewer Trunk Line
-  Force Sewer Line
-  Water Shed Dividing Line

5841 HOUSING UNITS

3310 HOUSING UNITS

POPLAR CREEK WATER SHED

CLINCH RIVER WATER SHED

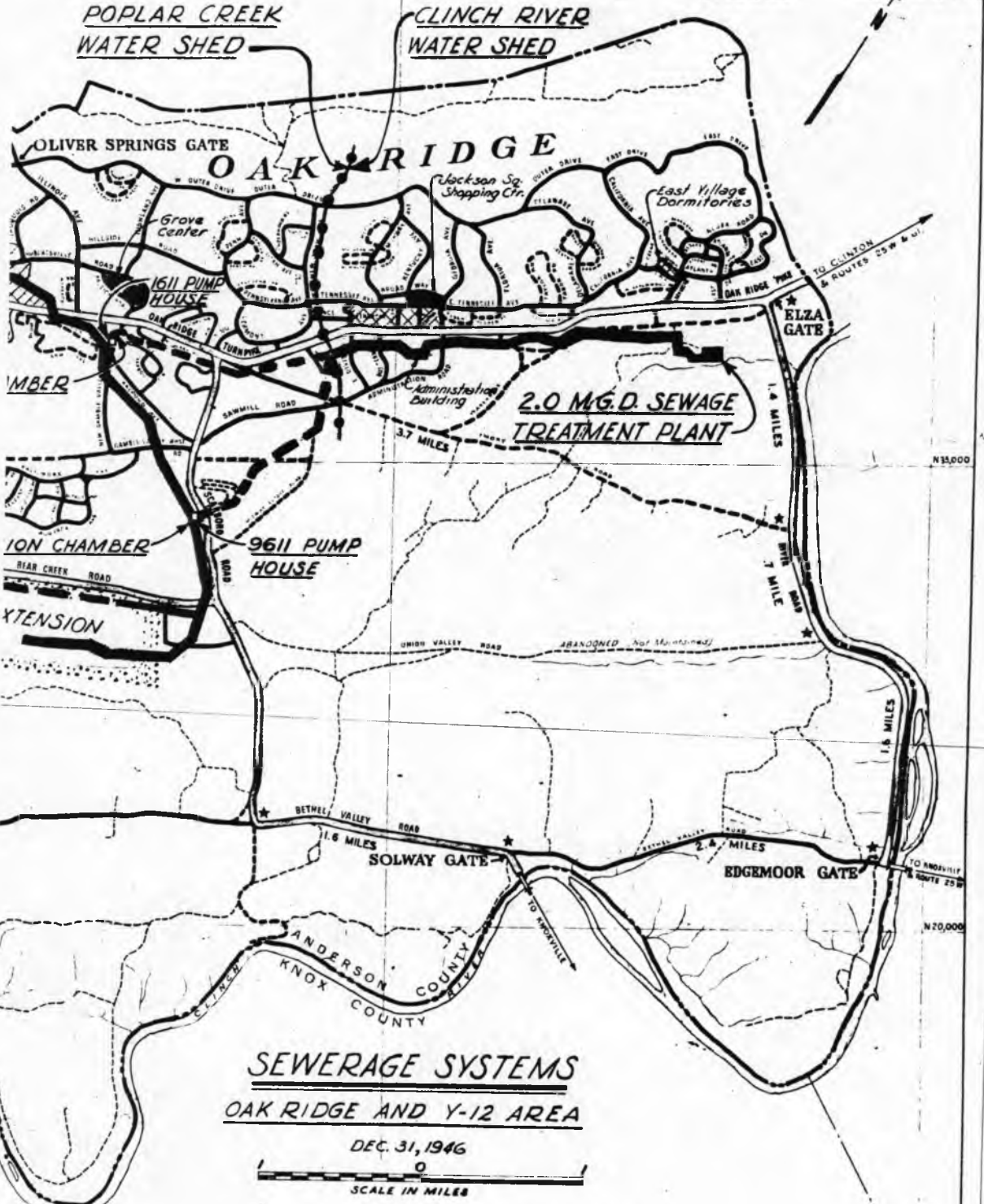

SEWERAGE SYSTEMS
OAK RIDGE AND Y-12 AREA

DEC. 31, 1946



- LEGEND**
- ▬ Gravity Sewer Trunk Line
 - ▬ Force Sewer Line
 - ◆ Water Shed Dividing Line

- ROAD LEGEND**
- ▬ Main Paved Roads
 - ▬ Secondary Paved Roads
 - ▬ Secondary Roads
 - ▬ Unimproved Roads
 - ★ 5.4 ★ Approximate mileage between stars

~~CONFIDENTIAL~~

MANHATTAN DISTRICT HISTORY

BOOK I - GENERAL

VOLUME 12 - CLINTON ENGINEER WORKS, CENTRAL FACILITIES

APPENDIX C - GRAPHS, CHARTS, & TABLES

~~CONFIDENTIAL~~

MANHATTAN DISTRICT HISTORY

BOOK I - GENERAL

VOLUME 12 - CLINTON ENGINEER WORKS, CENTRAL FACILITIES

APPENDIX C - GRAPHS, CHARTS, & TABLES

<u>NO.</u>	<u>TITLE</u>
1	Population Chart, Clinton Engineer Works
2	Employment Chart, CEW
3	Housing Cost Data
3a	Housing Contract Data
3b	Housing Availability & Occupancy (6 Sheets)
4	Trailer Installation Graph
5	Commercial Facilities, Contract Data (4 Sheets)
6	Schools and Medical Facilities, Contract Data
7	Electric Power Consumption and Costs, Clinton Engineer Works, October 1943 through December 1946
8	Schedule of Housing Rental Rates (2 Sheets)
8a	Sewerage System, Quantities and Unit Costs, 1944, 1945, and 1946
8b	Water Supply System, Quantities and Unit Costs, 1944, 1945, and 1946
9	Bus Operations, CEW, February 1944 through December 1946
10	Bus Operations, Off-Area, February 1944 through December 1946
10a	Off-Area Bus Subsidy Contractors, Communities Served, and Contract Termination Dates

Appendix C - Graphs, Charts, & Tables (cont'd).

<u>NO.</u>	<u>TITLE</u>
10b	Operational Costs, Bus System, AIT, February 1945 through December 1946
11	Administrative, Service, and Miscellaneous Buildings and Facilities
12	Cases Handled by Review Board, April 1945 through December 1946
13	Concession Report, December 1946 (10 Sheets)
13a	Equipment Rentals Report, December 1946 (3 Sheets)
14	Roane-Anderson Company Organizational Chart, 1944
15	Roane-Anderson Company Organizational Chart, 1945
16	Roane-Anderson Company Organizational Chart, 1 July 1946
17	Central Facilities Organizational Chart, March 1943
18	Central Facilities Organizational Chart, March 1944
19	Central Facilities Organizational Chart, March 1945
20	Facilities and Service Division Organizational Chart, 16 May 1946
21	Manhattan District Organizational Chart, 1 April 1943
22	Facilities and Service Division Organizational Chart, 5 November 1946
23	Communications Department Organizational Chart, 10 October 1946 (4 Sheets)
24	Department of Public Safety Organizational Chart, 11 October 1946 (5 Sheets)

6.1 POPULATION CHART, CLINTON ENGINEER WORKS

Population

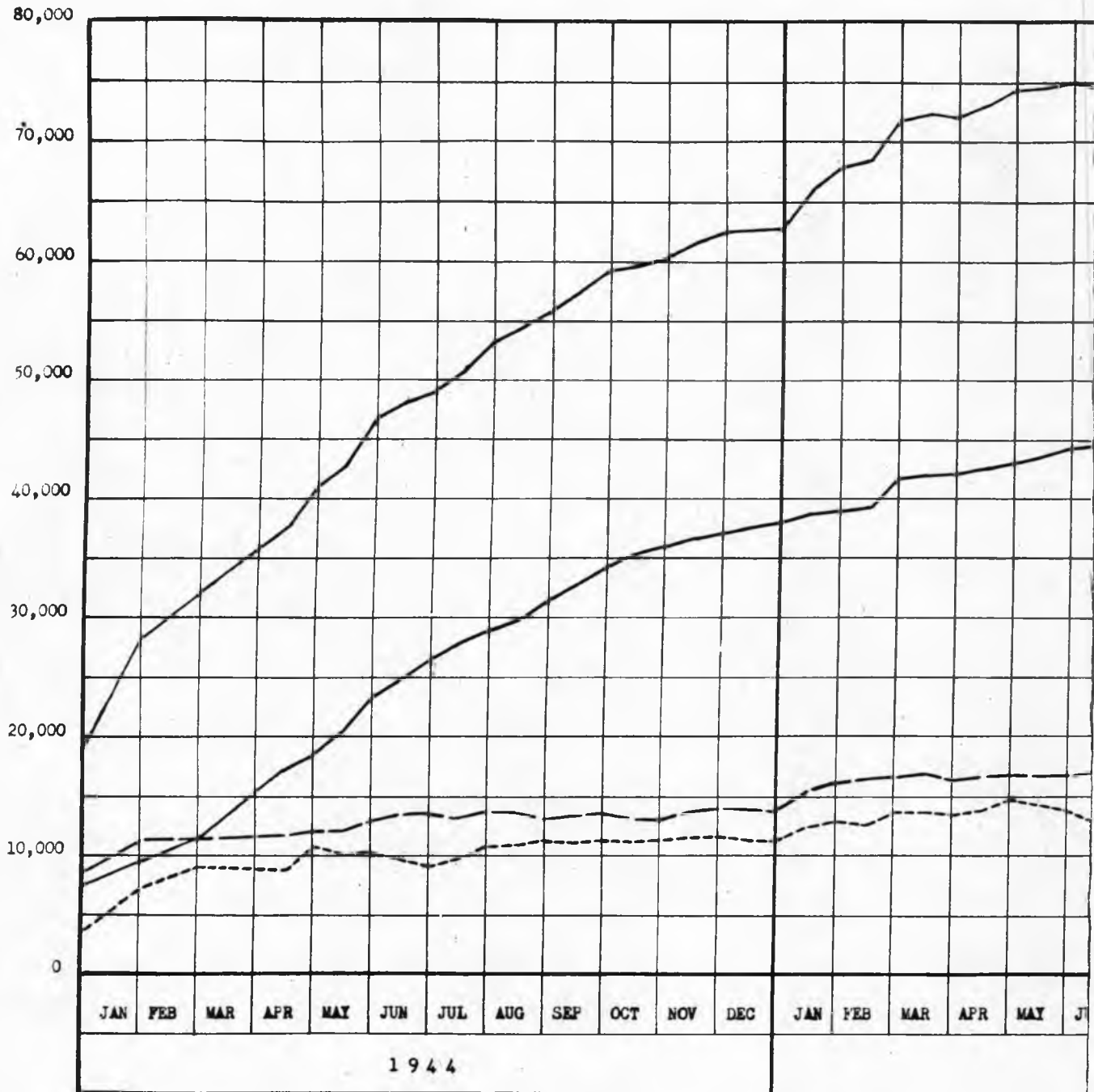

NOTES: (1) Curve 1 is the sum of Curves 2, 3, and 4.
 (2) Curve 2 includes population in permanent houses, cottages, apartments and dormitories located in Townsite, East Village, and West Village, EM Cantonment and farmhouses located throughout the entire CEW area.

NOTES: (3) Curve 3 covers pers trailers (excluding K-2)
 (4) Curve 4 includes pers Valley and Roane Anders

POPULATION
CLINTON ENGINEER WORKS

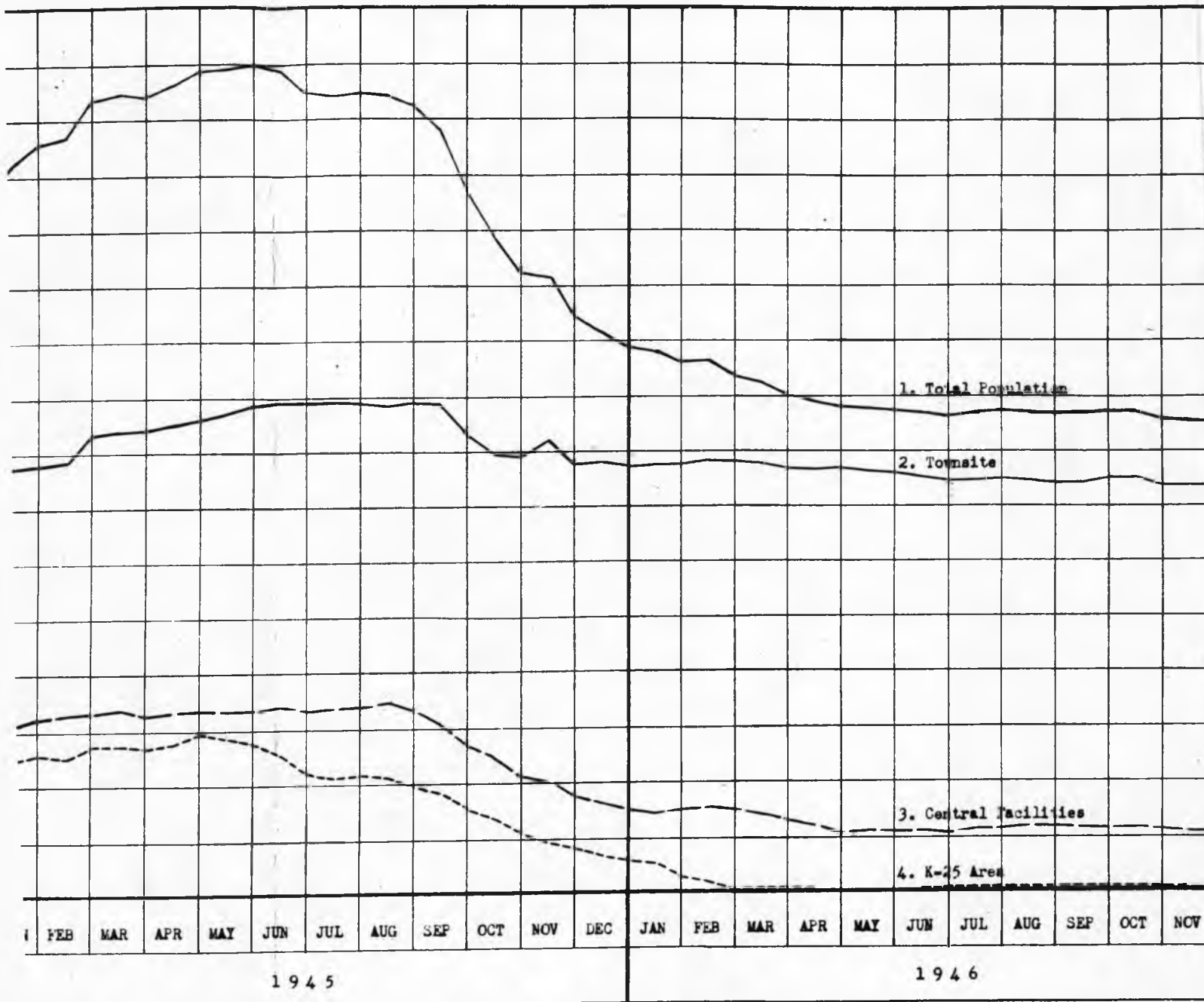

51 (3) Curve 3 covers persons housed in huts and trailers (excluding K-25).
 (4) Curve 4 includes persons living in Happy Valley and Roane Anderson wheat Colony.

0-1-2

Population

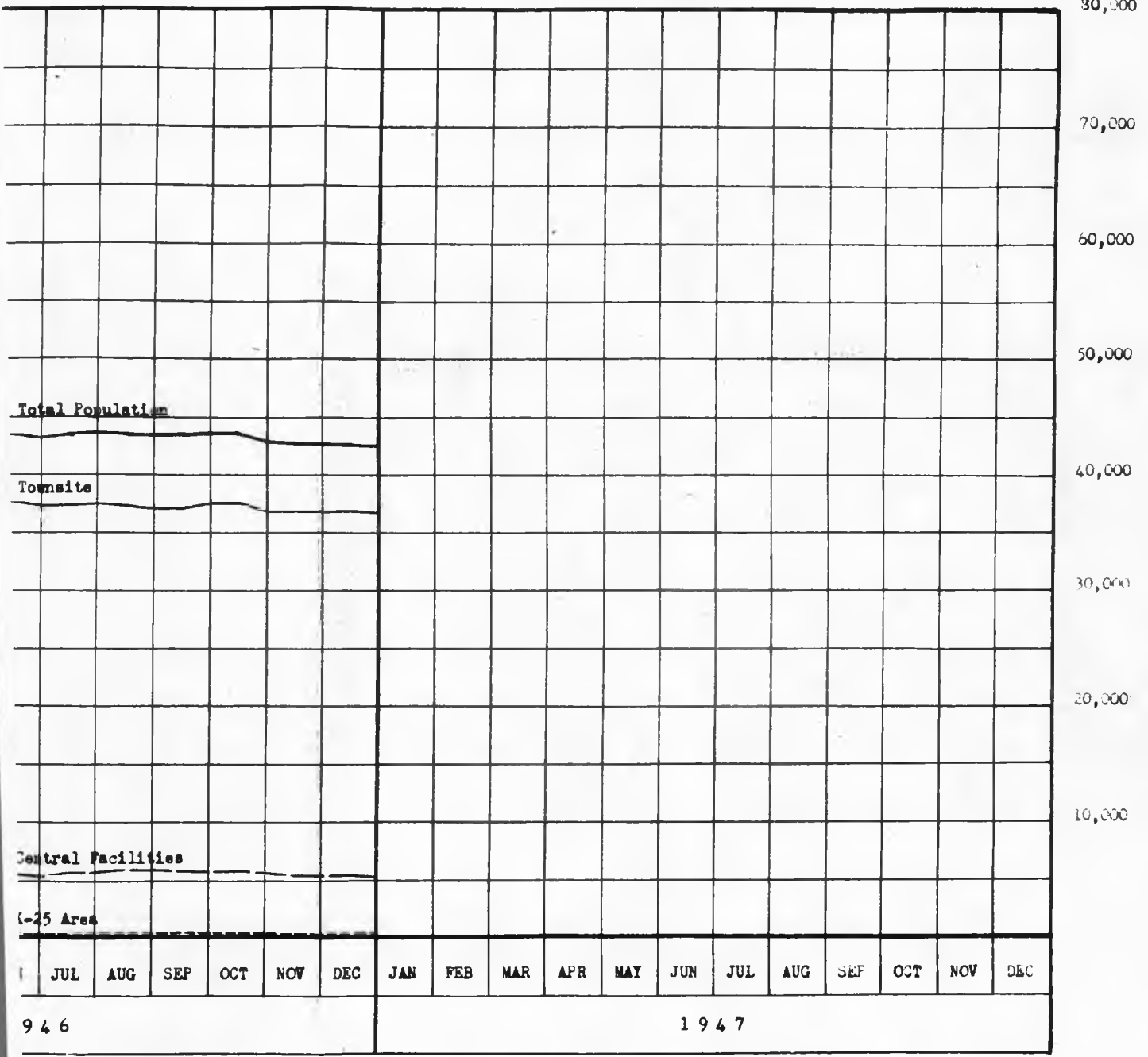

0-2 EMPLOYMENT CHART, CEW

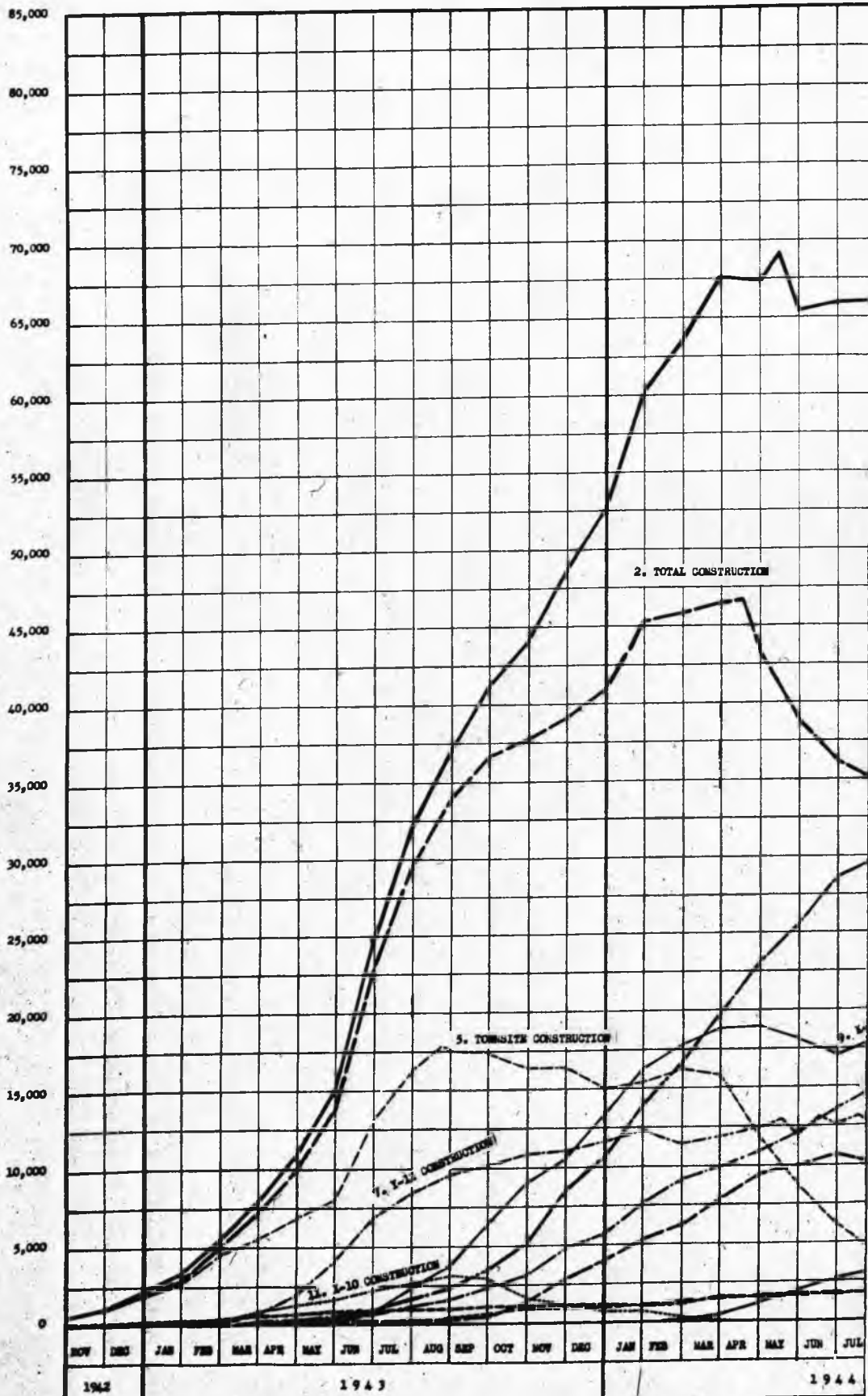

NOTES: (1) Operations Curves include Military Personnel assigned to Operating Contractors.
 (2) Curve 1 is the sum of Curves 2, 3, and that portion of Curve 4 not included in Operations Curves (see Note 1).

(3) Curve 2 is the sum of Curves 5, 7, 9, 11.
 (4) Curve 3 is the sum of Curves 6, 8, 10 and 13.

C2-1

EMPLOYMENT
CLINTON ENGINEERING WORKS

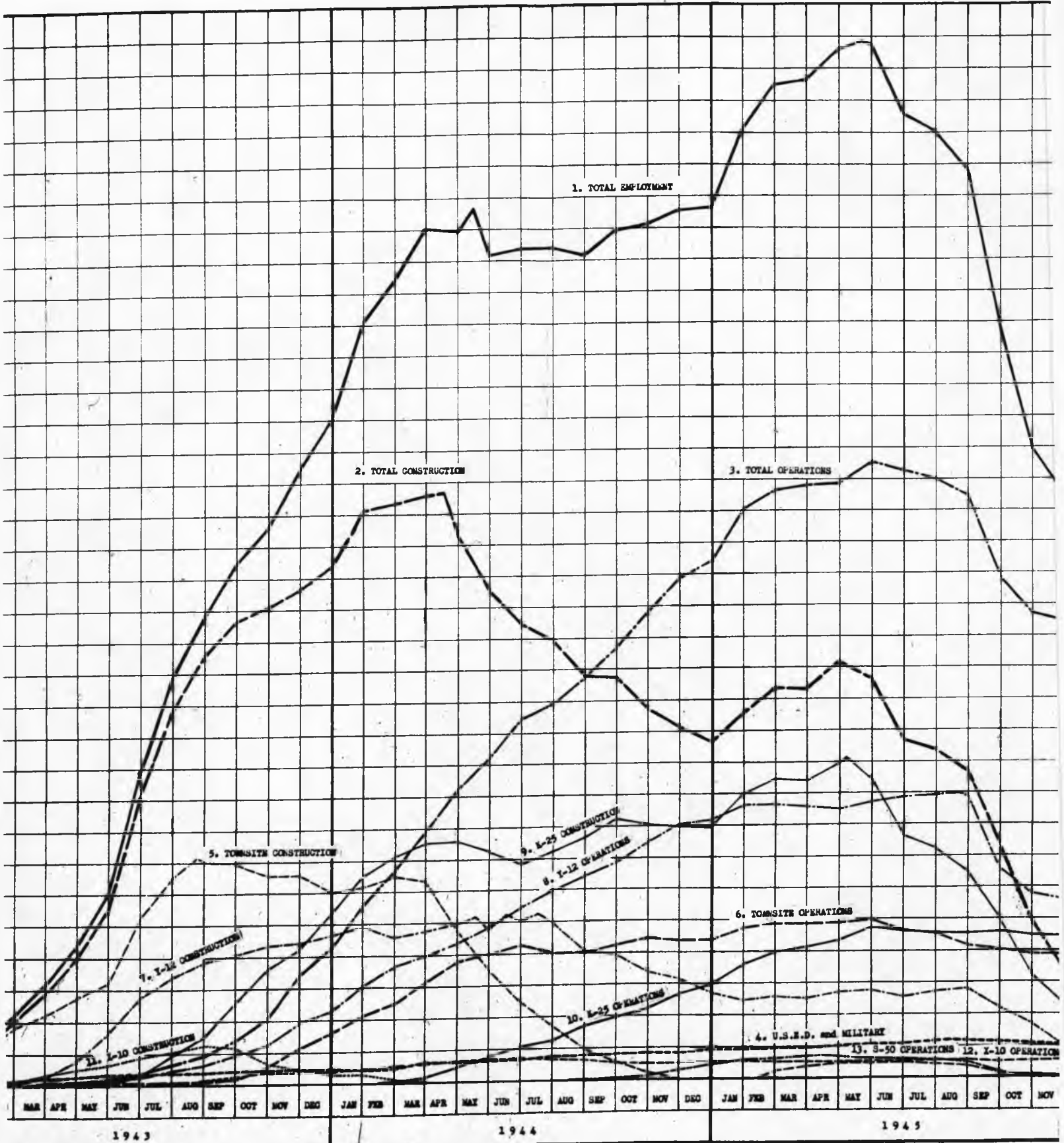

(1) Curves include Military Personnel to Operating Contractors.
(2) Curve 2 is the sum of Curves 5, 7, 9, and 11.
(3) Curve 3 is the sum of Curves 6, 8, 10, 12, and 13.
(4) Curve 4 not included in Operations (see Note 1).

(5) Curve 6 includes persons employed by concessionaires.
(6) Y-12 Curves include Y-12 Extension.

(7) Curve 7 includes persons employed by concessionaires.

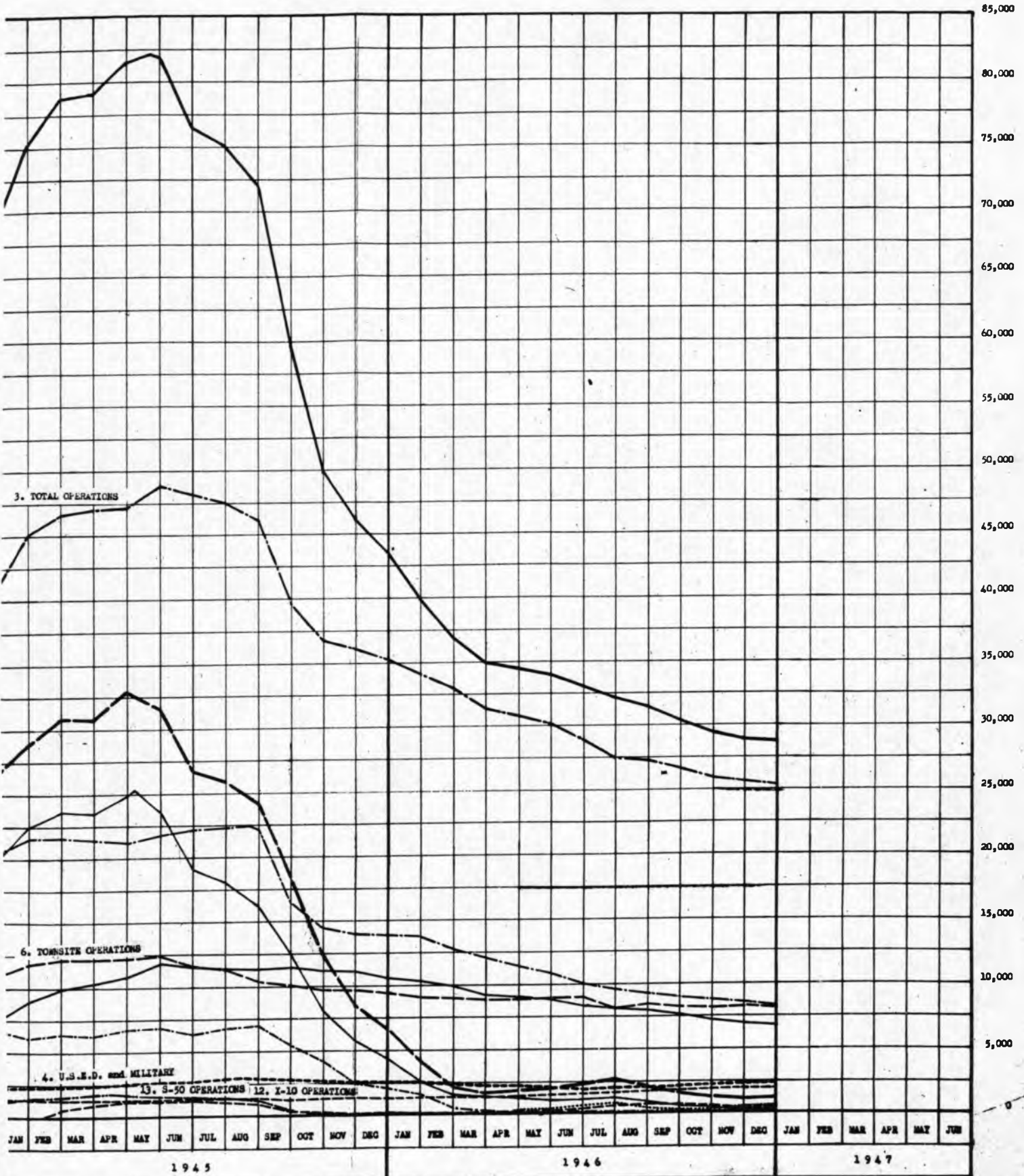

Curve 6 includes persons employed by concessionaires.
Y-12 Curves include Y-12 Extension.

(7) K-25 Curves include K-27/
(8) Estimated Requirements are shown in pencil.
CURRENT ESTIMATE IS AS OF:

1 JANUARY 1947

C-2
3

C-3 HOUSING COST DATA

0-3a HOUSING CONTRACT DATA

TYPE	NUMBER OF BUILDINGS	NUMBER OF DWELLING UNITS	DIRECT CONTRACT PAYMENTS
<u>HOUSES</u>			
<u>Cemesto</u>			
"A"	700	700	\$ 2,360,004.78
"B"	800	800	3,299,270.45
"C"	400	400	1,996,277.20
"D"	285	285	1,631,875.31
"D-D"	162	162	956,015.65
"E"	150	600	1,712,604.55
"F"	53	53	337,660.57
"G"	40	40	148,094.15
"H"	10	10	39,700.91
Total Cemesto	2,600	3,050	\$12,487,508.65
<u>Multi-Family</u>			
"K"	50	200	\$ 696,854.66
"L"	60	120	565,678.26
"N"	15	180	563,125.59
"T"	190	380	1,130,756.84
"U"	60	120	321,237.16
Total Multi-Family	375	1,000	\$ 3,277,652.51
<u>Pre-Fabricated</u>			
A-6	500	500	\$ 1,068,339.31
B-1	1,622	1,622	4,733,223.85
C-1	500	500	1,779,710.58
"V"	476	476	1,050,017.31
"S"	275	275	487,631.23
Total Pre-Fabricated	3,373	3,373	\$ 9,118,922.28
VC-1	375	750	\$ 791,938.69
TEU	477	970	\$ 2,004,651.58
TOTAL HOUSES	7,200	9,143	\$27,680,673.71
<u>OTHER HOUSING</u>			
apartments	3	113	\$ 515,593.76

Hutment Apartments	51	52		133,
"H" Dormitories	46		2,538,698.00	3,260,
"S" Dormitories	43		2,811,186.00	418,
Dormitory Conversion	5	122	236,586.23	34,
Trailer Camps	7 camps	3,904		1,114,
Hutments (Utility Bldgs.)	1,264 122	1,274		1,592,
Hutments (Johnson Area) (Utility Bldgs.)	107 5	117	17,900.00	1
Cantonment	74			404,0
Cantonment	52		106,332.69	22,6
TOTAL OTHER HOUSING			\$ 6,226,296.68	\$ 7,065,6
TOTAL ALL HOUSING			\$33,906,970.39	\$11,283,5
Furniture				
Contract Termination "W" & "S" houses			125,794.80	
GRAND TOTAL			\$34,032,765.19	\$11,283,5

- ① See App. A-193.
- ② Records, Cost Section, Administrative Division, Manhattan District.
- ③ Records, Audit Division, Roane-Anderson Company.
- ④ Manhattan District Contract Files and Records, Department of Public Works, Facilities & ...
- ⑤ See App. A-196.
- ⑥ Subject to revision.
- ⑦ See Section 19 for Fire Hall in Gamble Valley Trailer Camp.
- ⑧ Equipment and fixtures included in costs of buildings.

GENERAL FACILITIES

HOUSING COST DATA

THROUGH 31 DECEMBER 1946

SECTION COST ID/OR REGISTERED	TOTAL	CONSTRUCTION COST PER UNIT	EQUIPMENT & FIXTURES COST	
			CONTRACT PAYMENTS	GOVT. AND/OR STONE & WEBSITER INCURRED
512.95	\$ 2,722,622.73	\$ 3,889.46	\$ 65,946.00	\$ 206,088.16
51.28	3,794,131.73	4,742.66	111,981.00	266,388.45
508.19	2,268,785.47	5,671.96	56,219.00	160,546.95
118.05	1,906,993.36	6,691.20	74,775.15	142,497.74
203.05	1,116,018.70	6,889.00	43,268.58	77,252.93
706.50	1,945,311.05	3,242.19	41,352.00	163,776.83
85.45	391,246.02	7,382.00	16,502.93	25,799.90
334.26	160,428.41	4,010.71		11,291.49
28.16	43,129.07	4,312.91		2,709.82
57.89	\$14,348,666.54		\$ 410,044.66	\$ 1,056,352.27
57.74	\$ 801,912.40	\$ 4,009.56		\$ 57,372.23
231.05	722,909.31	6,024.24		58,484.69
86.98	652,512.57	3,625.07		46,348.31
24.97	1,172,071.81	3,084.40		83,742.54
76.22	334,213.38	2,785.11		26,647.77
66.96	\$ 3,683,619.47			\$ 272,595.54
91.16	\$ 1,330,730.47	\$ 2,661.46		\$ 145,760.03
74.10	5,653,797.95	3,485.70		389,346.37
30.23	2,116,440.81	4,232.88		126,832.90
95.54	1,128,712.25	2,371.25	\$ 34,237.50	83,346.05
70.86	521,802.09	1,897.46	34,237.50	37,812.50
51.89	\$10,751,484.17		\$ 68,475.00	\$ 783,097.85
56.52	\$ 840,595.21	\$ 1,120.79	\$ 56,250.00	
50.64	\$ 2,274,212.22	\$ 2,344.55		
33.90	\$31,898,577.61		\$ 534,769.66	\$ 2,112,045.66
1.62	\$ 601,415.38	\$ 5,322.26		

57.94	133,157.94	2,560.73
6.20	5,799,044.20	126,066.18
31.78	3,229,517.78	75,105.06
61.97	271,148.20	2,222.53
39.61	1,114,339.61***	
01.96	1,592,201.96	1,249.77
80.00	18,080.00	154.53
41.92	404,041.92	
60.00	128,972.69	
23.00	\$13,291,919.68	

26.90	\$45,190,497.29	\$ 534,769.66	\$ 2,112,045.66	\$ 2,646,815.32
			1,780,456.44	1,780,456.44
	125,794.80			

26.90	\$45,316,292.09	\$ 534,769.66	\$ 3,892,502.10	\$ 4,427,271.76
-------	-----------------	---------------	-----------------	-----------------

Service Division, Manhattan District.

C3-4

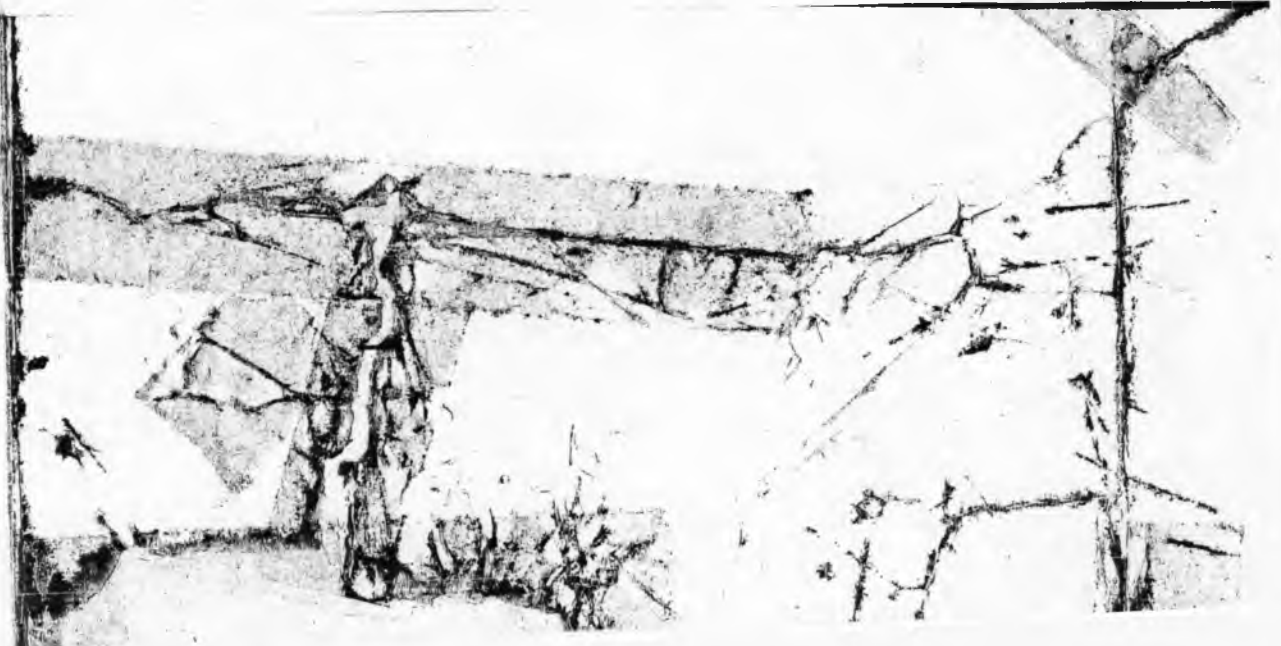

TOTAL	TOTAL DIRECT COST	INDIRECT COST	GRAND TOTAL	SOURCE OF INFORMATION
272,034.16	\$ 2,994,656.89	\$ 508,873.45	\$ 3,503,530.34	Ø
378,369.45	\$ 4,172,501.18	709,021.15	4,881,522.33	Ø
765.95	2,485,551.42	422,362.62	2,907,914.04	Ø
217,272.77	2,124,266.25	360,970.47	2,485,236.72	Ø
120,521.51	1,834,540.21	210,121.73	1,446,661.94	Ø
205,128.83	2,150,439.88	365,418.08	2,515,857.96	Ø
42,302.83	433,548.85	73,671.71	507,220.56	Ø
11,291.49	171,719.90	* 29,179.87	200,899.77	Ø
2,709.82	45,838.89	7,789.27	53,628.16	Ø
1,466,396.93	\$15,815,063.47	\$ 2,687,408.35	\$18,502,471.82	
57,372.23	\$ 859,284.63	\$ 146,015.77	\$ 1,005,300.40	Ø
58,484.69	781,394.00	132,780.04	914,174.04	Ø
46,348.31	698,860.38	118,755.43	817,616.31	Ø
83,742.54	1,255,814.35	213,396.93	* 1,469,211.28	Ø
26,647.77	360,861.15	61,320.10	422,181.25	Ø
272,595.54	\$ 3,956,215.01	\$ 672,268.27	\$ 4,628,483.28	
145,760.03	\$ 1,476,490.50	\$ 250,895.79	\$ 1,727,386.29	Ø
389,346.37	6,043,144.32	1,026,894.18	7,070,038.50	Ø
126,832.90	2,243,273.71	381,193.23	2,624,466.94	Ø
117,583.55	1,246,296.40	139,417.37	1,385,713.77	Ø and *
72,050.00	593,852.09	44,912.47	638,764.56	*
851,572.85	\$11,603,057.02	\$ 1,843,313.04	\$13,446,370.06	
56,250.00	\$ 896,845.21	\$ 57,737.71	\$ 954,582.92	*
	\$ 2,274,212.22	\$ 386,450.35	\$ 2,660,662.57	Ø
646,815.32	\$34,545,392.93	\$ 5,647,177.72	\$40,192,570.55	
	\$ 601,415.38	\$ 102,196.79	\$ 703,612.17	Ø

Hutment Apartments	51	52	
"H" Dormitories	46	-	2,538,698.00
"S" Dormitories	43	-	2,811,186.00
Dormitory Conversion	5	122	236,586.23
Trailer Camps	7 camps	3,904	
Hutments (Utility Bldgs.)	1,264 122	1,274	
Hutments (Johnson Area) (Utility Bldgs.)	107 5	117	17,900.00
Sanitation	74		
Sanitation	52		106,332.69
TOTAL OTHER HOUSING			\$ 6,226,296.68
TOTAL ALL HOUSING			\$33,906,970.39
Furniture			
Contract Termination "V" & "g" Houses			125,794.80
TOTAL TOTAL			\$34,032,765.19

† See App. A-193.
 * Records, Cost Section, Administrative Division, Manhattan District.
 # Records, Audit Division, Roane-Anderson Company.
 †† Manhattan District Contract Files and Records, Department of Public Works, Facilities.
 ††† See App. A-196.
 †††† Subject to revision.
 ††††† See Section 19 for Fire Hall in Gamble Valley Trailer Camp.
 †††††† Equipment and fixtures included in costs of buildings.

CONTRACT NUMBER	CONTRACTOR	TYPE	NUMBER OF BUILDINGS
W-7415-eng-1	O'Driscoll & Grove, Inc.	"A"	300
		"B"	200
		"C"	200
		"D"	100
		"E"	50
	Total this contract		850
W-7415-eng-6	Clinton Home Builders	"A"	200
		"B"	300
		"C"	100
		"D-D"	162
		"E"	50
	Total this contract		850
W-7418-eng-7	John A. Johnson Contr. Corp.	"A"	200
		"B"	300
		"C"	100
		"D"	185
		"E"	50
	Total this contract		850
W-7415-eng-10	O'Driscoll & Grove, Inc.	"G"	40
		"H"	10
	Total this contract		50
W-7421-eng-4	Coupe Construction Company	"K"	50
		"L"	60
		"M"	15
	Total this contract		125
W-7415-eng-48	Foster & Creighton Company	"T"	190
		"U"	60
	Total this contract		250
W-7401-eng-72	Schult Trailers, Inc.	A-6	150
W-7401-eng-138	Schult Trailers, Inc.	A-6	350
		B-1	200
	Total this contract		550
W-7401-eng-71	National Homes, Inc.	B-1	100
W-7401-eng-128	National Homes, Inc.	B-1	248
W-7401-eng-143	National Homes, Inc.	B-1	34
W-7401-eng-208	National Homes, Inc.	B-1	340
W-7401-eng-144	Gundison Housing Corp.	B-1	200
W-7401-eng-145	Alma Trailers, Inc.	B-1	500
W-7401-eng-139	E. L. Bruce Co.	C-1	500
W-7418-eng-71	John A. Johnson Contr. Corp.	"V"	201
W-14-108-eng-55	John A. Johnson Contr. Corp.	"V"	275
W-14-108-eng-57	John A. Johnson Contr. Corp.	"S"	275

W-7418-eng-72	John A. Johnson Contr. Corp.	TDU	110
W-7415-eng-8	Foster & Creighton Co.	Apartments	1
W-7415-eng-12	Foster & Creighton Co.	Apartments	2
W-7415-eng-7	Foster & Creighton Co.	"H" Dormitories	4
W-7418-eng-9	Foster & Creighton Co. A. Farnell Blair	"H" Dormitories	3
W-7418-eng-10	A. Farnell Blair	"H" Dormitories	24
W-7418-eng-65	A. Farnell Blair	"H" Dormitories	5
W-7415-eng-51	Clinton Home Builders	"S" Dormitories	23
W-14-108-eng-52	John A. Johnson Contr. Corp.	"S" Dormitories	14
W-14-108-eng-64	John A. Johnson Contr. Corp.	"S" Dormitories	6
W-7418-eng-100	John A. Johnson Contr. Corp.	Hutments	107**
W-28-094-eng-46	John A. Johnson Contr. Corp.	"H" Dormitory Conversion	4
W-31-109-eng-53	John A. Johnson Contr. Corp.	"S" Dormitory Conversion	1
W-7401-eng-115	Reese-Anderson Co.*	Canteen	52
W-7401-eng-13	Stons & Webster Engr. Corp.*	Hutment Apartments "H" Dormitories Hutments Trailer Camps Canteen	51 10 1,244*** 7 74
Total this contract			1,406
W-14-108-eng-71	John A. Johnson Contr. Corp.***	"H" & "S"	

GRAND TOTAL HOUSING CONTRACT PAYMENTS

*Work done as part of general contracts of Stons & Webster
 **Hutment utility buildings were also constructed.
 ***122 hutment utility buildings were also constructed.
 ****Contract termination costs.
 *****Where possible, equipment costs have been separated from

EQUIPMENT COSTS	CONSTRUCTION COSTS	DATE COMPLETED	DATE STARTED	NUMBER OF UNITS
28,262.57	951,265.89			200
27,995.25	836,667.95			200
28,109.90	1,022,619.36			200
28,236.89	577,051.95			100
19,784.00	608,231.87			200
124,388.21	3,993,937.02	28 December 1943	5 April 1943	1,000
18,841.71	688,416.11			200
41,992.88	1,222,140.35			300
11,054.75	473,380.57			100
49,848.88	956,015.65			162
11,000.00	1,000,000.00			200

GENERAL FACILITIES
 HOUSING CONTRACT DATA
 THROUGH 31 DECEMBER 1946

CENTRAL FACILITIES
HOUSING CONTRACT DATA
THROUGH 31 DECEMBER 1946

NUMBER OF UNITS	DATE STARTED	DATE COMPLETED	BUILDING COSTS
300			\$ 951,365.89
200			836,667.95
200			1,022,619.36
100			577,051.95
200			606,231.87
1,000	5 April 1943	28 December 1943	\$ 3,993,937.02
200			\$ 688,416.11
300			1,222,140.35
100			473,380.57
162			956,015.65
200			563,981.53
38			242,227.46
1,000	14 June 1943	29 February 1944	\$ 4,146,161.67
200			\$ 726,227.78
300			1,240,462.15
100			500,277.35
185			1,054,823.36
200			542,391.15
15			95,433.11
1,000	26 August 1943	11 May 1944	\$ 4,159,614.90
40			\$ 148,094.15
10			39,700.91
50	27 July 1943	27 November 1943	\$ 187,795.06
200			\$ 696,854.66
120			565,678.26
180			563,125.59
500	30 November 1943	31 July 1944	\$ 1,825,658.51
380			\$ 1,130,756.84
120			321,237.16
500	11 January 1944	12 June 1944	\$ 1,451,994.00
150	21 September 1943	31 January 1944	\$ 335,611.76
350			\$ 732,727.55
200			584,212.00
550	19 November 1943	30 January 1944	\$ 1,316,939.55
100	21 September 1943	4 February 1944	\$ 281,267.70
248	9 November 1943	1 May 1944	\$ 698,787.11
34	22 November 1943	31 May 1944	\$ 90,268.61
340	15 May 1944	26 July 1944	\$ 954,556.96
200	22 November 1943	7 June 1944	\$ 558,408.10
500	22 November 1943	19 May 1944	\$ 1,565,723.37
500	19 November 1943	19 May 1944	\$ 1,779,710.58
201	6 March 1944	1 May 1944	\$ 476,305.12
275	12 February 1945	10 November 1945	\$ 573,712.19
275	12 March 1945	9 November 1945	\$ 487,631.23
250	7 July 1945	14 November 1945	\$ 281,065.80
500	5 February 1945	12 June 1945	\$ 510,872.89
266	21 January 1944	26 April 1944	\$ 599,186.43

C3a-3

17 November 1943	1 May 1944	\$ 476,305.12
6 March 1944	10 November 1945	\$ 573,712.19
12 February 1945	9 November 1945	\$ 487,631.23
12 March 1945	14 November 1945	\$ 281,065.80
7 July 1945	12 June 1945	\$ 510,872.89
5 February 1945	26 April 1944	\$ 599,186.43
21 January 1944	26 April 1944	\$ 960,592.00
21 January 1944	31 May 1944	\$ 444,873.15
25 February 1944	8 January 1944	\$ 220,554.10
3 July 1943	8 January 1944	\$ 295,039.66
3 July 1943	23 October 1943	\$ 429,134.00
24 June 1943	27 December 1943	\$ 159,169.00
29 September 1943	30 March 1944	\$ 1,579,145.00
25 October 1943	14 April 1944	\$ 371,250.00
10 November 1943	25 May 1944	\$ 1,611,186.00
19 February 1944	17 October 1945	\$ 834,192.00
13 January 1945	6 November 1945	\$ 365,808.00
28 July 1945		\$ 17,900.00
		\$ 168,885.87
1 April 1946		\$ 67,700.36
3 June 1946		\$ 106,332.69
		\$ 125,794.80
		<u>\$34,032,765.19</u>

erson Company.

g costs.

C 3a-4

EQUIPMENT COSTS	TOTAL CONTRACT PAYMENTS *****	STONE & WEBSTER COSTS
\$ 28,262.57	\$ 979,628.46	
27,995.25	864,663.20	
28,109.50	1,050,728.00	
26,236.89	603,288.84	
13,784.00	620,015.87	
<hr/>		
\$ 124,388.21	\$ 4,118,325.23	
\$ 18,841.71	\$ 707,257.82	
41,992.88	1,264,133.23	
14,054.75	487,435.32	
43,264.58	999,284.23	
13,784.00	577,765.53	
11,832.29	254,059.75	
<hr/>		
\$ 143,774.21	\$ 4,289,935.88	
\$ 18,841.72	\$ 745,069.50	
41,992.87	1,282,455.02	
14,054.75	514,332.10	
48,538.26	1,103,361.62	
13,784.00	556,175.15	
4,670.64	100,103.75	
<hr/>		
\$ 141,882.24	\$ 4,301,497.14	
=	\$ 148,094.15	
	39,700.91	
<hr/>		
	\$ 187,795.06	
	\$ 696,854.66	
	565,678.26	
	563,125.59	
	<hr/>	
	\$ 1,825,658.51	
	\$ 1,130,756.84	
	321,237.16	
	<hr/>	
	\$ 1,451,994.00	
	\$ 335,611.76	
	\$ 732,727.55	
	584,212.00	
	<hr/>	
	\$ 1,316,939.55	
	\$ 281,267.70	
	\$ 698,787.11	
	\$ 90,268.61	
	\$ 954,556.96	
	\$ 558,408.10	
	\$ 1,565,723.37	
	\$ 1,779,710.58	
	\$ 476,305.12	
\$ 34,237.50	\$ 607,949.69	
\$ 34,237.50	\$ 521,868.73	
\$ 18,750.00	\$ 299,815.80	
\$ 37,500.00	\$ 548,372.89	
	\$ 599,186.43	

86

\$ 220,554.10
 \$ 295,039.66
 \$ 429,134.00
 \$ 159,169.00
 \$ 1,579,145.00
 \$ 371,250.00
 \$ 1,611,186.00
 \$ 834,192.00
 \$ 365,808.00
 \$ 17,900.00
 \$ 168,885.87
 \$ 67,700.36
 \$ 106,332.69

\$ 155,785.09
 \$3,260,346.20
 1,862,760.27
 1,303,676.14
 472,673.09
 \$7,055,260.79

\$ 125,794.80

\$ 534,769.66 \$34,569,534.85 \$7,055,260.79

C-3-a-6

\$ 688,116.11
 1,222,140.35
 473,380.57
 956,015.65

162
 100
 300

C-3b HOUSING AVAILABILITY & OCCUPANCY (6 Sheets)

<u>TYPE</u>	<u>NUMBER CONSTRUCTED</u>	<u>AVAILABLE FOR OCCUPANCY 31 DECEMBER 1946</u>
<u>HUTMENTS</u>		
White	699	
White Family		100*
Supervisory	101	
Colored		
Single	450	164
Single Family	4	102
Double Family	10	
Johnson Area	<u>107</u>	
TOTAL	1,371	<u>366</u>

*Other hutments converted to use as white family quarters.

**Excess of available and occupied over number constructed due to conversion of un

AVAILABLE FOR OCCUPANCY
31 DECEMBER 1946

OCCUPIED
31 DECEMBER 1946

100*

71*

164

164

102

102

—
366

—
337

y quarters.

constructed due to conversion of units from purpose for which constructed.

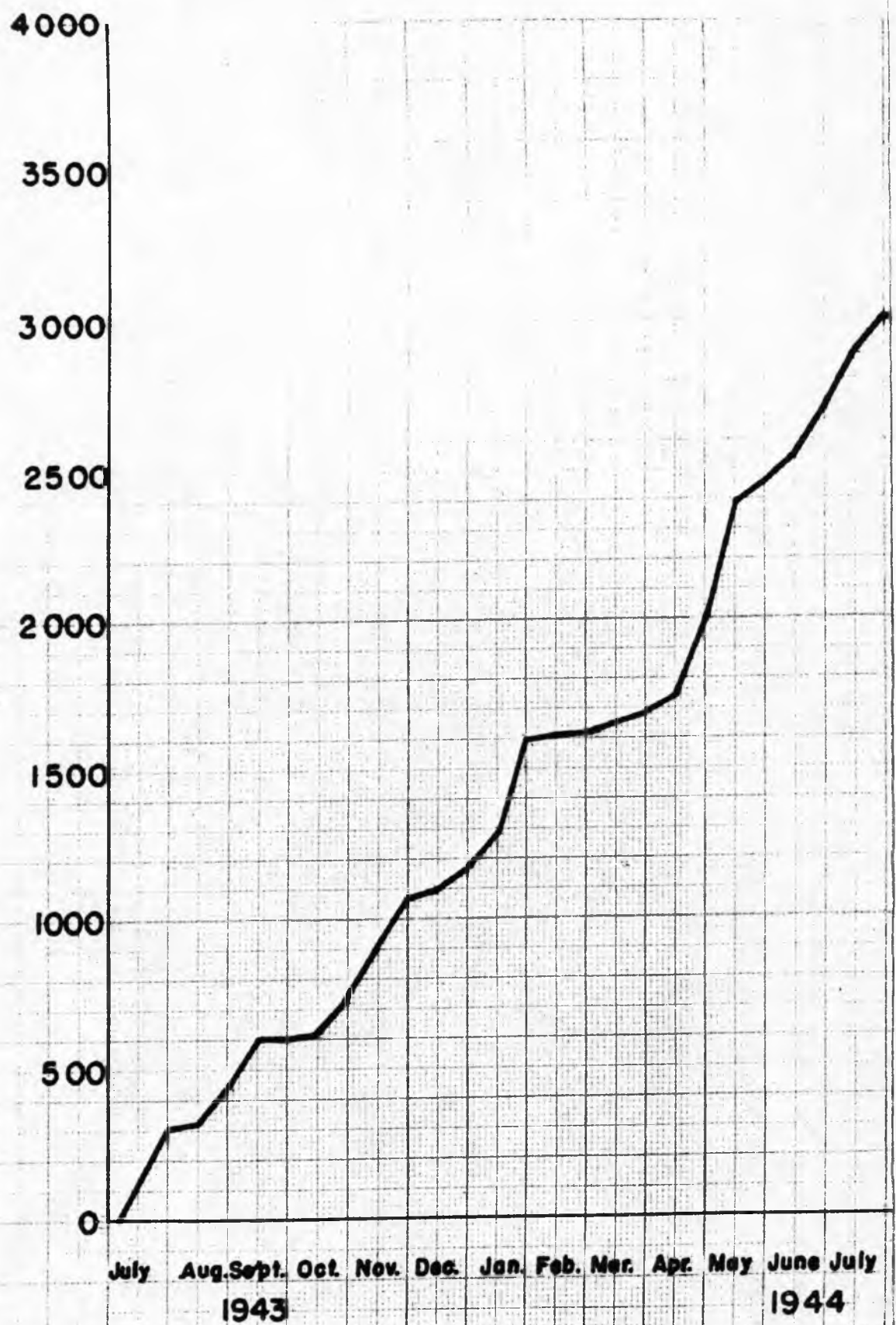

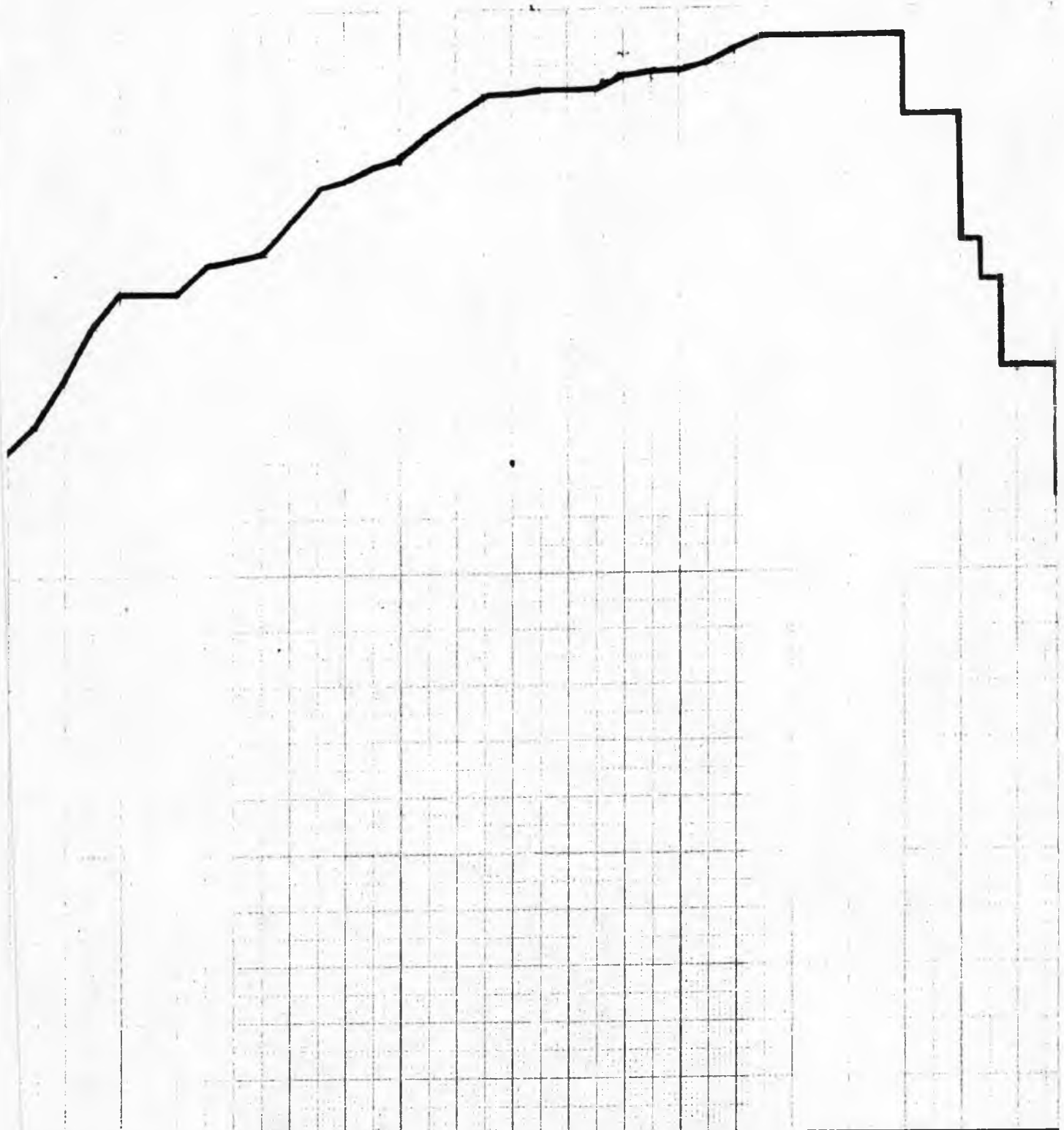

June July Aug. Sept. Oct. Nov. Dec. Jan. Feb. Mar. Apr. May June July Aug. Sept. Oct. Nov. Dec.
 1944 1945

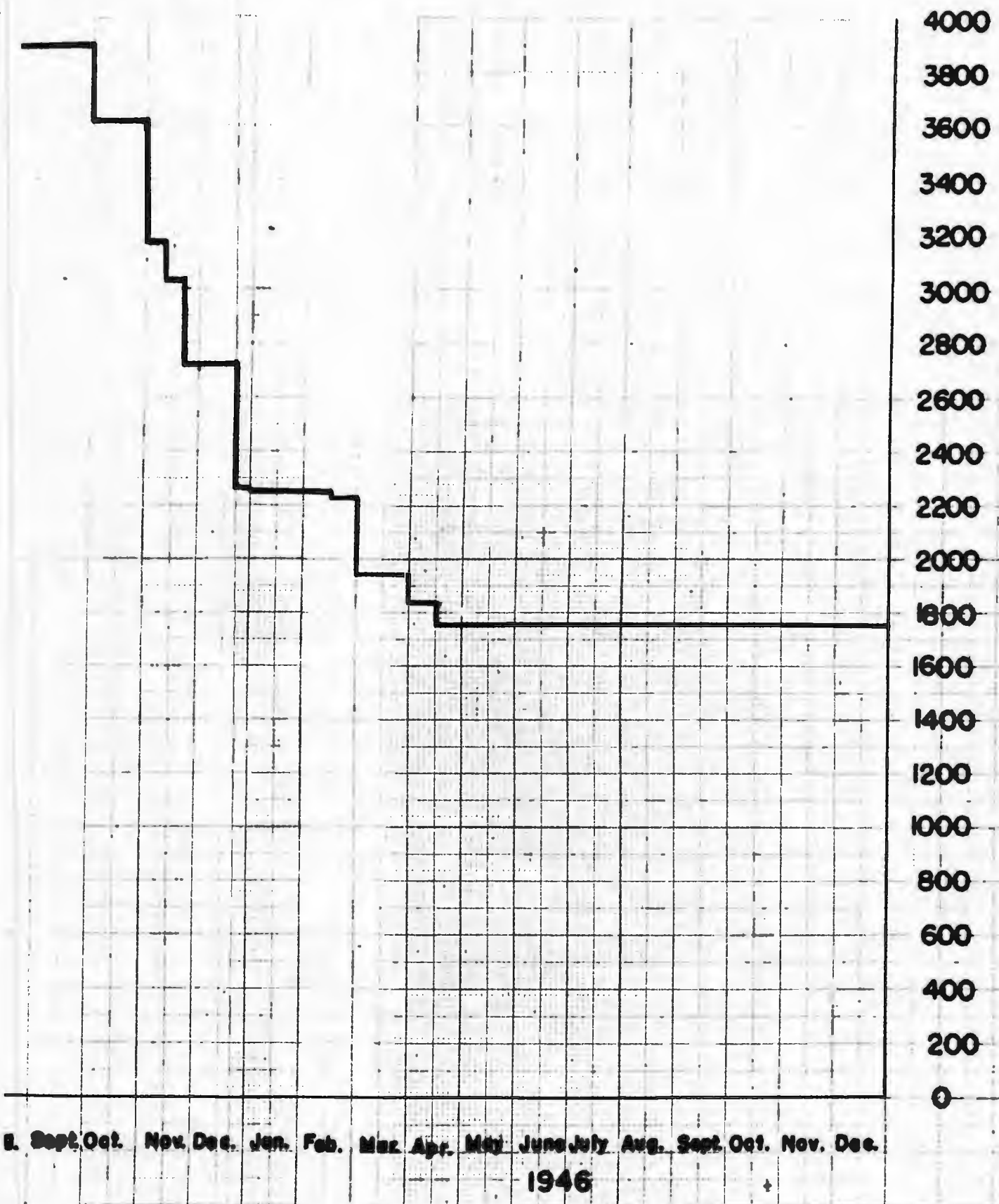

TRAILERS

TYPE (Cont'd.)

<u>VICTORY COTTAGES</u>	<u>UNITS CONSTRUCTED (Cont'd.)</u>	<u>AVAILABLE FOR OCCUPANCY, 28 DECEMBER 1946 (Cont'd.)</u>	<u>OCCUPIED 28 DECEMBER 1946 (Cont</u>
White		523	469
Colored	—	<u>220</u>	<u>220</u>
Subtotal	750	743	689
TOTAL HOUSE UNITS	<u>9,143</u>	<u>9,124</u>	<u>9,017</u>

BUTMENT APARTMENTS

52

52

52

APARTMENTS

Types 1A & 1B

One bedroom

46

46

46

Two bedrooms

2

2

2

Type 2

65

65

65

Converted Dormitory Types

"S"

42

42

42

"H"

TYPE (Cont'd.)

BUILDINGS
CONSTRUCTED (Cont'd.)

DORMITORIES (Cont'd.)

Warehouses

Closed

TOTAL

TYPE

PEAK NUMBER

TRAILERS

Government-Owned

3,950 (Approx.)

Privately-Owned

269

TOTAL

4,219

TYPE

PEAK NUMBER
AVAILABLE

FARM HOUSES

165 (Approx.)

BUILDING USE
31 DECEMBER 1946 (Cont'd.)

3

43

89

AVAILABLE FOR OCCUPANCY
31 DECEMBER 1946

OCCUPIED
31 DECEMBER 1946

1,777

1,396

41

41

1,818

1,437

AVAILABLE FOR OCCUPANCY
31 DECEMBER 1946

OCCUPIED
31 DECEMBER 1946

109 (Approx.)

102 (Approx.)

TYPE (Cont'd.)

<u>APARTMENTS (Cont'd.)</u>	<u>UNITS CONSTRUCTED (Cont'd.)</u>
One bedroom, large living room	12
One bedroom, small living room	24
Two bedrooms, large living room	24
Two bedrooms, small living room	4
One bedroom, large living room, porch	<u>16</u>
TOTAL	235

TYPE

BUILDINGS
CONSTRUCTED

DORMITORIES

89

Bachelor Men's Quarters

Bachelor Women's Quarters

Married Couples Quarters

Apartments, Converted Buildings

Military Barracks

Hotels

Office Buildings

AVAILABLE FOR
OCCUPANCY. 28 DECEMBER 1946 (Cont'd.)

OCCUPIED
28 DECEMBER 1946 (C

12	11
24	24
24	23
4	4
<u>16</u>	<u>16</u>
235	233

BUILDING USE
31 DECEMBER 1946

13
19
14
5
2
14
1
- 4 -

CENTRAL FACILITIES
HOUSING AVAILABILITY AND OCCUPANCY AT END OF 1946

<u>TYPE</u>	<u>UNITS CONSTRUCTED</u>	<u>AVAILABLE FOR OCCUPANCY, 28 DECEMBER 1946</u>	<u>OCCUPIED 28 DECEMBER 1946</u>
CFMESTL			
"A"	700	700	699
"B"	800	800	798
"C"	400	400	400
"D"	285	285	283
"D-D"	162	162	162
"E" (One bedroom)	300	298	298
"E" (Two bedrooms)	300	298	294
"F"	53	53	52
"G"	40	40	40
"H"	<u>10</u>	<u>10</u>	<u>10</u>
Subtotal	3,050	3,046	3,036
MULTI-FAMILY			
"K" (Two bedrooms)	100	100	100
"K" (One bedroom)	100	100	100
"L" (Three bedrooms)	60	60	60
"L" (Two bedrooms)	60	60	60

TYPE (Cont'd.)

<u>MULTI-FAMILY</u> (Cont'd.)	<u>UNITS CONSTRUCTED</u> (Cont'd.)
"R"	180
"T" (Three bedrooms)	190
"T" (Two bedrooms)	190
"U"	<u>120</u>
Subtotal	1,000
 <u>PREFABRICATED</u>	
A-6	500
B-1	1,622
C-1	500
"V"	476
"S"	<u>275</u>
Subtotal	<u>3,373</u>
 <u>DEMOUNTABLE</u>	
One bedroom	140
Two bedrooms	680
Three bedrooms	<u>150</u>
Subtotal	970

AVAILABLE FOR
OCCUPANCY, 28 DECEMBER 1946 (Cont'd.)

OCCUPIED
28 DECEMBER 1946 (Cont

180	180
190	187
190	188
<u>120</u>	<u>116</u>
1,000	991
500	497
1,621	1,616
499	497
471	461
<u>274</u>	<u>270</u>
3,365	3,341
140	140
680	670
<u>150</u>	<u>150</u>
970	960

Q-5 COMMERCIAL FACILITIES, CONTRACT DATA (4 Sheets)

CENTRAL FACILITIES

CONTRACT DATA, COMMERCIAL FACILITIES

Through 31 December 1946

<u>BLDG.</u> <u>NO.</u>	<u>DESCRIPTION</u>	<u>CONTRACTOR</u>	<u>CONTRACT NO.</u>	<u>DATE</u> <u>BEGUN</u>	<u>DA</u> <u>COMP</u>
1804-T	Guest House	Stone & Webster	W-7401-eng-13		
1805-T-1	Cafeteria No. 1	Stone & Webster	W-7401-eng-13	3-20-43#	9-25
1805-T-2	Cafeteria No. 2	O'Driscoll & Grove, Inc.	W-7415-eng-17	11-17-43	4-3-
1306	Boiler House	Stone & Webster	W-7401-eng-13		
1805-T-3	Cafeteria No. 3	O'Driscoll & Grove, Inc.	W-7421-eng-37	2-10-44	6-5-
1805-T-4	Cafeteria No. 4	J. A. Johnson Contracting Co.	W-7418-eng-156	5-9-44	8-6-
1816-T	Mess Hall East Village	Foster & Creighton	W-7415-eng-7	7-4-43	10-5
1817-T-1	Laundry No. 1	Stone & Webster	W-7401-eng-13	3-19-43	9-15
1817-T-2	Laundry No. 2	O'Driscoll & Grove, Inc.	W-7421-eng-5	11-24-43	4-5-
1818-T-1	Garage & Filling Station	Stone & Webster	W-7401-eng-13	6-9-43	10-5
1818-T-2	(Garage & Filling Station)	A. Farnell Blair	W-7418-eng-104)	2-1-44)	3-29
1818-T-3	(Garage & Filling Station)	A. Farnell Blair	W-7418-eng-104)	2-1-44)	3-29
1820-T	Auto Repair Shop	J. A. Johnson Contracting Co.	W-7418-eng-102	4-1-44	6-17
1826-T	(Neighborhood Store No. 1)	Foster & Creighton	W-7415-eng-16)	9-13-43)	11-2
1827-T	(Neighborhood Store No. 2)	Foster & Creighton	W-7415-eng-16)	10-6-43)	12-3
1828-T	(Neighborhood Store No. 3)	Foster & Creighton	W-7415-eng-16)	9-13-43)	11-2
1829-T	Neighborhood Store No. 4	O'Driscoll & Grove, Inc.	W-7415-eng-47	1-8-44	3-31
1830	Dry Cleaning Plant	Stone & Webster	W-7401-eng-13	4-11-44	6-17
1831-T	Town Center Bldg. No. 1	Foster & Creighton	W-7415-eng-2	5-11-43	9-2-
1832-T	Town Center Bldg. No. 2	Foster & Creighton	W-7415-eng-2	5-14-43	9-2-
1833-T	Town Center Bldg. No. 3	Foster & Creighton	W-7415-eng-2	5-16-43	9-2-
1836-T	Town Center Bldg. No. 4	A. Farnell Blair	W-7418-eng-39	11-5-43	3-12
1837-T	Town Center Bldg. No. 5	A. Farnell Blair	W-7418-eng-39	11-8-43	3-21
1838-T	Town Center Bldg. No. 6	A. Farnell Blair	W-7418-eng-39	11-29-43	4-1-
1870-T	Neighborhood Store No. 8	O'Driscoll & Grove, Inc.	W-7421-eng-38	2-10-44	5-12

Month, day, year; contract dates only.

CONTRACT DATA, COMMERCIAL FACILITIES

Through 31 December 1946

	<u>CONTRACTOR</u>	<u>CONTRACT NO.</u>	<u>DATE BEGUN</u>	<u>DATE COMPLETED</u>	<u>ACTUAL COST*</u>
	Stone & Webster	W-7401-eng-13			\$ 205,415.51
	Stone & Webster	W-7401-eng-13	3-20-43#	9-25-43	432,908.44
	O'Driscoll & Grove, Inc.	W-7415-eng-17	11-17-43	4-3-44	326,787.38
	Stone & Webster	W-7401-eng-13			37,477.65
	O'Driscoll & Grove, Inc.	W-7421-eng-37	2-10-44	6-5-44	189,559.59
	J. A. Johnson Contracting Co.	W-7418-eng-156	5-9-44	8-6-44	176,415.49
Village	Foster & Creighton	W-7415-eng-7	7-4-43	10-5-43	60,853.89
	Stone & Webster	W-7401-eng-13	3-19-43	9-15-43	326,097.97
	O'Driscoll & Grove, Inc.	W-7421-eng-5	11-21-43	4-5-44	286,454.74
ig Station	Stone & Webster	W-7401-eng-13	6-9-43	10-5-43	34,944.26
ig Station)	A. Farnell Blair	W-7418-eng-104)	2-1-44)	3-29-44)	44,099.68
ig Station)	A. Farnell Blair	W-7418-eng-104)	2-1-44)	3-29-44)	
ip	J. A. Johnson Contracting Co.	W-7418-eng-102	4-1-44	6-17-44	66,462.88
ore No. 1)	Foster & Creighton	W-7415-eng-16)	9-13-43)	11-28-43)	
ore No. 2)	Foster & Creighton	W-7415-eng-16)	10-6-43)	12-31-43)	226,869.46
ore No. 3)	Foster & Creighton	W-7415-eng-16)	9-13-43)	11-23-43)	
ore No. 4	O'Driscoll & Grove, Inc.	W-7415-eng-47	1-8-44	3-31-44	71,281.98
ant	Stone & Webster	W-7401-eng-13	4-11-44	6-17-44	26,033.42
ig. No. 1	Foster & Creighton	W-7415-eng-2	5-11-43	9-2-43	205,768.13
ig. No. 2	Foster & Creighton	W-7415-eng-2	5-11-43	9-2-43	126,319.94
ig. No. 3	Foster & Creighton	W-7415-eng-2	5-16-43	9-2-43	68,429.05
ig. No. 4	A. Farnell Blair	W-7418-eng-39	11-5-43	3-13-44	218,954.36
ig. No. 5	A. Farnell Blair	W-7418-eng-39	11-8-43	3-25-44	159,976.97
ig. No. 6	A. Farnell Blair	W-7418-eng-39	11-29-43	4-1-44	123,912.98
ore No. 8	O'Driscoll & Grove, Inc.	W-7421-eng-38	2-10-44	5-12-44	106,641.38

ear; contract dates only.

COMMERCIAL FACILITIES (Cont'd)

<u>BLDG.</u> <u>NO.</u>	<u>DESCRIPTION</u>	<u>CONTRACTOR</u>	<u>CONTRACT NO.</u>	<u>DATE</u> <u>BEGUN</u>	<u>DI</u> <u>COM</u>
1871-T	Retail Store Group A	J. A. Johnson Contracting Co.	W-7418-eng-105	4-20-44	7-21
1932-T	Bank - Middletown	Stone & Webster	W-7401-eng-13	11-30-43	6-11
1933-T-1	Barber Shops - Middletown and Town Center	Stone & Webster	W-7401-eng-13	11-30-43	6-11
1971-T-1	Store No. 1 - Middletown	Stone & Webster	W-7401-eng-13	8-23-43	6-11
1971-T-2	Store No. 2 - Middletown	Stone & Webster	W-7401-eng-13	10-12-43	6-11
1971-T-3	Store No. 3 - Middletown	Stone & Webster	W-7401-eng-13	12-15-43	6-11
1941-T-2	Chicken Farm	Stone & Webster	W-7401-eng-13		
RA-1873	Middletown Theatre	Stone & Webster	W-7401-eng-13	8-14-43	11-1

SUBTOTAL (ACTUAL COSTS)

<u>PROJECT</u> <u>NO.</u>	<u>DESCRIPTION</u>	<u>CONTRACTOR</u>	<u>CONTRACT NO.</u>	<u>DATE</u> <u>BEGUN</u>	<u>DI</u> <u>COMPI</u>
	Trailer Camp No. 3 Grocery Store	Stone & Webster	W-7401-eng-13	8-27-43	11-1
	Trailer Camp No. 6 Grocery Store	Stone & Webster	W-7401-eng-13	11-12-43	5-29
1, 2, 3, 4	Gamble Valley Service Sta. Gamble Valley Neighborhood Stores	Stone & Webster	W-7401-eng-13	4-25-44	5-30
11C & 12	2 Service Stations &	J. A. Johnson Contracting Co.	W-7401-eng-115	8-7-44	12-2
11B & 13	2 Garages	Sullivan, Long & Hagerty	W-22-075-eng-113	8-2-45	11-1
5	Store Bldg. at Grove Center	J. A. Johnson Contracting Co.	W-14-108-eng-69	7-1-45	11-2
1 & 3	2 Grocery Stores and 2 Drug Stores	Dykes & Gerhardt	W-22-075-eng-114	8-2-45	12-6
4	Store Bldg. at Gamble Valley	Dykes & Gerhardt	W-22-075-eng-86	4-25-45	9-21
2, 15, & 20	Store, Office & Library	Dykes & Gerhardt	W-22-075-eng-104	5-29-45	10-9
26 to 29	4 Hostess Houses Negro Hutment Area Beauty Shop	J. A. Johnson Contracting Co.	W-14-108-eng-65	5-24-45	12-1
		Roane-Anderson Company	W-7401-eng-115	8-16-45	9-21

	<u>CONTRACTOR</u>	<u>CONTRACT NO.</u>	<u>DATE BEGUN</u>
	J. A. Johnson Contracting Co.	W-7418-eng-105	4-20-44
	Stone & Webster	W-7401-eng-13	11-30-43
	Stone & Webster	W-7401-eng-13	11-30-43
1	Stone & Webster	W-7401-eng-13	8-23-43
1	Stone & Webster	W-7401-eng-13	10-12-43
1	Stone & Webster	W-7401-eng-13	12-15-43
	Stone & Webster	W-7401-eng-13	
	Stone & Webster	W-7401-eng-13	8-14-43

SUBTOTAL (ACTUAL COSTS)

	<u>CONTRACTOR</u>	<u>CONTRACT NO.</u>	<u>DATE BEGUN</u>
	Stone & Webster	W-7401-eng-13	8-27-43
	Stone & Webster	W-7401-eng-13	11-12-43
sa.	Stone & Webster	W-7401-eng-13	4-25-44
ood	J. A. Johnson Contracting Co.	W-7401-eng-115	8-7-44
	Sullivan, Long & Hagerty	W-22-075-eng-113	8-2-45
ster	J. A. Johnson Contracting Co.	W-14-108-eng-69	7-1-45
	Dykes & Gerhardt	W-22-075-eng-114	8-2-45
alley	Dykes & Gerhardt	W-22-075-eng-86	4-25-45
	Dykes & Gerhardt	W-22-075-eng-104	5-29-45
	J. A. Johnson Contracting Co.	W-14-108-eng-65	5-24-45
	Roane-Anderson Company	W-7401-eng-115	8-16-45

<u>DATE COMPLETED</u>	<u>ACTUAL COST*</u>
7-24-44	‡ 301,051.14
6-15-44	8,492.83
6-15-44	7,461.25
6-15-44	73,292.38
6-15-44	29,119.59
6-15-44	38,744.98
	17,793.15
11-15-43	<u>109,965.46</u>
	‡ 4,107,615.93

<u>DATE COMPLETED</u>	<u>APPROXIMATE COST**</u>
11-13-43	‡ 12,000.00
5-29-44	17,000.00
5-30-44	2,700.00
12-23-44	29,924.50
11-14-45	97,570.35
11-27-45	54,591.51
12-6-45	92,911.26
9-21-45	22,394.08
10-9-45	55,306.22
12-4-45	77,801.50
9-21-45	2,421.00

COMMERCIAL FACILITIES (Cont'd)

<u>PROJECT NO.</u>	<u>DESCRIPTION</u>	<u>CONTRACTOR</u>	<u>CONTRACT NO.</u>	<u>DATE BEGUN</u>	<u>DATE COMPLE</u>
	Store Bldg. at Farmers Market	Roane-Anderson Company	W-7401-eng-115	7-10-45	9-21
	Middletown Hardware & Appliance Store (Constructed from Hutment Units)	Roane-Anderson Company	W-7401-eng-115	7-19-45	8-7
	Uniform Service Co. (Constructed from Hutment Units)	Roane-Anderson Company	W-7401-eng-115	7-19-45	8-11
	Drive-In Canteen Highway 61 & Robertsville Rd. (Existing Camp Office altered by Gov't. Agent to Drive-In Canteen)	Roane-Anderson Company	W-7401-eng-115	8-2-45	10-1
	Middletown Woodworking & Furniture Repair Shop (Constructed from Hutment Units)	Roane-Anderson Company	W-7401-eng-115	7-17-45	10-1
	Ice Plant Raccoon Ave. & Sable Road	Roane-Anderson Company	W-7401-eng-115	4-9-45	6-21
	Service Station Highway 61 & Illinois Ave. (Moving Bldg, Grading & Outside work, Concessionaire pay other expense)	Roane-Anderson Company	W-7401-eng-115	4-14-45	7-21
	Concession Area at Oak Ridge Pike & Illinois Ave. (Constructed from Hutment Units)	Roane-Anderson Company	W-7401-eng-115	9-4-44	11-2
	Concession Area at Farmers Market - Highway 61 & West Division Road.	Roane-Anderson Company	W-7401-eng-115	9-16-44	2-20
	(Produce Co. in Farmers Market - Highway 61 & W. Division Road	Roane-Anderson Company	W-7401-eng-115	11-11-44	11-2
	(Produce Co. in Farmers Market - Highway 61 & W. Division Road	Roane-Anderson Company	W-7401-eng-115	1-11-45	1-21
	(Farmers Retail Market West Division Road	Roane-Anderson Company	W-7401-eng-115	4-2-45	5-22

COMMERCIAL FACILITIES (Cont'd)

	<u>CONTRACTOR</u>	<u>CONTRACT NO.</u>
Market	Roane-Anderson Company	W-7401-eng-115
Appliance on Hutment		
Instructed	Roane-Anderson Company	W-7401-eng-115
by 61 & sting Camp t. Agent	Roane-Anderson Company	W-7401-eng-115
& Furniture ted from	Roane-Anderson Company	W-7401-eng-115
	Roane-Anderson Company	W-7401-eng-115
oad	Roane-Anderson Company	W-7401-eng-115
1 Ave. & Outside pay other		
Ridge Pike structed	Roane-Anderson Company	W-7401-eng-115
ers Market -	Roane-Anderson Company	W-7401-eng-115
ision Road.	Roane-Anderson Company	W-7401-eng-115
Market -		
ision Road	Roane-Anderson Company	W-7401-eng-115
Market -		
ision Road	Roane-Anderson Company	W-7401-eng-115
	Roane-Anderson Company	W-7401-eng-115

<u>DATE BEGUN</u>	<u>DATE COMPLETED</u>	<u>APPROXIMATE COST**</u>
7-10-45	9-21-45	Included in Farmers' Market. See *** below.
7-19-45	8-7-45	\$ 12,423.00
7-19-45	8-14-45	2,981.00
8-2-45	10-30-45	
7-17-45	10-10-45	3,708.88
4-9-45	6-25-45	278,564.00
4-14-45	7-21-45	4,698.00
9-4-44	11-2-44	11,518.00
9-16-44	2-20-45	32,165.00***
11-11-44	11-25-44)	Included in
1-11-45	1-25-45)	cost of Farm-
4-2-45	5-23-45)	ers' Market
		See ***

COMMERCIAL FACILITIES (cont'd)

<u>PROJECT NO.</u>	<u>DESCRIPTION</u>	<u>CONTRACTOR</u>	<u>CONTRACT NO.</u>	<u>DATE BEGUN</u>	<u>DATE COMPLETE</u>
	Taxi Cab Stand				
	Tennessee Ave. & Towne Road	Roane-Anderson Company	W-7401-eng-115	6-22-44	7-3-44
	Auto Repair Shop and	Roane-Anderson Company	W-7401-eng-115	4-30-45	6-3-45
	Shoe Repair Shop, Gamble Valley			6-8-45	8-7-45
	Jackson Square Arcade	Fletcher-Moore Company	W-14-153-eng-48	1946	1946
	Music Shop, Jackson Square	Fletcher-Moore Company	W-28-094-eng-43	1946	1946
	Mayflower Grill, Town Center****			1946	1946
	Y-12 Service Station			1946	1946
	Galesburg Hall Office Building	Roane-Anderson Company		1946	1946
				SUBTOTAL (APPROXIMATE COSTS)	
				TOTAL (ACTUAL AND APPROXIMATE)	

- * See App. A-193 for reference to source of cost data.
- ** See Apps. A-183, A-196, A-225, A-306, and A-314 for reference to source of cost data.
- *** Approximate total cost of construction of entire Farmers' Market Area.
- **** Construction costs incurred by concessionaire not shown.

COMMERCIAL FACILITIES (cont'd)

	<u>CONTRACTOR</u>	<u>CONTRACT NO.</u>	<u>DATE BEGUN</u>
Road	Roane-Anderson Company	W-7401-eng-115	6-22-44
	Roane-Anderson Company	W-7401-eng-115	4-30-45
Valley			6-8-45
	Fletcher-Moore Company	W-44-153-eng-48	1946
	Fletcher-Moore Company	W-28-094-eng-43	1946
er****			1946
			1946
ding	Roane-Anderson Company		1946
SUBTOTAL (APPROXIMATE COSTS)			
TOTAL (ACTUAL AND APPROXIMATE)			

reference to source of cost data.

196, A-225, A-306, and A-314 for reference to source of cost data.

cost of construction of entire Farmers' Market Area.

incurred by concessionaire not shown.

DATE
COMPLETED

APPROXIMATE
COST**

7-3-44	\$ 2,100.00
6-3-45)	
8-7-45)	3,154.21
1946	21,750.00
1946	3,764.66
1946	2,500.00
1946	7,530.00
1946	8,940.49

\$ 860,417.66

\$ 4,968,039.³59

0-6 SCHOOLS AND MEDICAL FACILITIES, CONTRACT DATA

SCHOOL FACILITIES

<u>BLDG. NO.</u>	<u>SCHOOL NO.</u>	<u>DESCRIPTION</u>	<u>CONTRACTOR</u>
1812-T		Athletic Field, High School	Stone & Webster Engr. Cor
1834-T		(High School	Foster & Creighton Compan
1834-T-1A		(High School Addition	John A. Johnson Contracti
1835-T-1	2	(Pine Valley School	Rock City Constr. Company
1835-T-2	1	(Elm Grove School	Rock City Constr. Company
1835-T-3	3	(Cedar Hill School	Rock City Constr. Company
1835-T-4	4	Glenwood School	O'Driscoll & Grove, Inc.
1877-T-1	5	Highland View School	John A. Johnson Contracti
1880-T		Robertsville School Alteration	Stone & Webster Engr. Cor
1880-T-1A		(Robertsville School, Additions	John A. Johnson Contracti
		(A, B, C, & D	Stone & Webster Engr. Cor
	6	Linden School	John A. Johnson Contracti
1880-T-1A		Robertsville School Gym	Sullivan, Long & Hagerly
1880-T-1A		(Robertsville School Addition	John A. Johnson Contracti
None		(Fairview School	John A. Johnson Contracti
None		(Gamble Valley School	John A. Johnson Contracti
None		Scarboro School	Acquired with reservation
		(Nursery (Tennyson)	Dykes & Gerhardt
		(Nursery (Grove)	Dykes & Gerhardt
		(Nursery (Gamble Valley) (Closed)	Dykes & Gerhardt
None		(Fairview School Alterations	John A. Johnson Contracti
None		(Gamble Valley School Alterations	John A. Johnson Contracti
		Wheat School	J. A. Jones Construction

MEDICAL FACILITIES

<u>BLDG. NO.</u>	<u>DESCRIPTION</u>	<u>CONTRACTOR</u>
1706	Medical Service Building***	Stone & Webster Engr. Co
1810-T	(Hospital	Rock City Constr. Compan
1810-T-1	(Hospital Addition No. 1	J. E. Anderson & Son
1810-T-1A	(Hospital Addition No. 2	O'Driscoll & Grove, Inc.
1810-T-1B	Hospital Addition No. 3	Roane-Anderson Company
1808-T	Outpatient Wings***	O'Driscoll & Grove, Inc.
1811-T	Nurses' Home	Foster & Creighton Compan
1823-T-1	Nurses' Dormitory	Clinton Home Builders
1809-T	Dental Clinic	John A. Johnson Contract
1839-T	Storage Bldg., Inflam. Gases	Stone & Webster Engr. Co
1910	Field Hospital****	Stone & Webster Engr. Co
1810-T-1A	Alterations, Psychiatric Ward	Roane-Anderson Company
1809-T	Alterations, Dental Clinic	Roane-Anderson Company
1810-T	Addition to Kitchen	Roane-Anderson Company
1810-T	Emergency & Receiving Entrance	Clinton Construction Co.
	Veterinary Building	
1809-T	Practitioners' Offices, Dental Clinic	Roane-Anderson Company
	Colored Dentist's Office	Roane-Anderson Company

Gamble Valley Dispensary (Closed)
K-25 Area Dispensary (Closed)

*Order: Month, day, year. Contract dates only.
 **For sources of cost data, see Apps. A-193, A-196, A-306, and
 ***Subsequently converted to use as District Communications Bul
 ****Name subsequently changed to Medical Arts Building.
 *****Subsequently converted to use as Public Health Center.

CONTRACT DATA, SCHOOL AND MEDICAL FACILITIES

THROUGH 31 DECEMBER 1946

SCHOOL FACILITIES

NO.	DESCRIPTION	CONTRACTOR	CONTRACT NO.	DATE* STARTED	DATE COMPLETED
	Athletic Field, High School	Stone & Webster Engr. Corp.	W-7401-eng-13	8-20-43	11-4
	(High School)	Foster & Creighton Company	W-7415-eng-9	7-13-43	11-1
	(High School Addition)	John A. Johnson Contracting Corp.	W-7418-eng-161	7-10-44	9-10
2	(Pine Valley School)	Rock City Constr. Company	W-7415-eng-11	8-3-43	11-1
1	(Elm Grove School)	Rock City Constr. Company	W-7415-eng-11	10-11-43	12-1
3	(Cedar Hill School)	Rock City Constr. Company	W-7415-eng-11	8-3-43	11-6
4	Glenwood School	O'Driscoll & Grove, Inc.	W-7415-eng-52	3-23-43	7-9
5	Highland View School	John A. Johnson Contracting Corp.	W-7418-eng-158	5-29-44	8-2
	Robertsville School Alteration	Stone & Webster Engr. Corp.	W-7401-eng-13	8-11-43	1-14
	(Robertsville School, Additions	John A. Johnson Contracting Corp. and	W-7418-eng-162)	8-1-44	11-1
	(A, B, C, & D	Stone & Webster Engr. Corp.	W-7401-eng-13)		
6	Linden School	John A. Johnson Contracting Corp.	W-14-108-eng-65	5-17-45	12-4
	Robertsville School Gym	Sullivan, Long & Hagerty	W-22-075-eng-127	8-27-45	12-4
	(Robertsville School Addition	John A. Johnson Contracting Corp.	W-14-108-eng-69	6-26-45	11-2
	(Fairview School	John A. Johnson Contracting Corp.	W-14-108-eng-69	6-26-45	11-2
	(Gamble Valley School	John A. Johnson Contracting Corp.	W-14-108-eng-69	6-26-45	11-2
	Scarboro School	Acquired with reservation; built by Anderson County, 1939, with Federal Funds.			
	(Nursery (Tennyson)	Dykes & Gerhardt	W-22-075-eng-114	7-28-45	12-4
	(Nursery (Grove)	Dykes & Gerhardt	W-22-075-eng-114	7-28-45	12-4
	(Nursery (Gamble Valley) (Closed)	Dykes & Gerhardt	W-22-075-eng-114	7-28-45	12-4
	(Fairview School Alterations	John A. Johnson Contracting Corp.	W-17-028-eng-132	1946	1946
	(Gamble Valley School Alterations	John A. Johnson Contracting Corp.	W-17-028-eng-132	1946	1946

Actual Cost Sub-Total

Wheat School

J. A. Jones Construction Co.

1944 (Estimated Cost)

ACTUAL AND ESTIMATED TOTAL, SCHOOL FACI

MEDICAL FACILITIES

DESCRIPTION	CONTRACTOR	CONTRACT NO.	DATE* STARTED	DATE COMPLETED
Medical Service Building***	Stone & Webster Engr. Corp.	W-7401-eng-13	3-3-43	6-8
(Hospital	Rock City Constr. Company	W-7415-eng-5	6-17-43	11-1
(Hospital Addition No. 1	J. E. Anderson & Son	W-7401-eng-167	3-16-44	10-1
(Hospital Addition No. 2	O'Driscoll & Grove, Inc.	W-7421-eng-31	4-29-44	8-1
Hospital Addition No. 3	Roane-Anderson Company	W-7401-eng-115	3-1-45	Not
Outpatient Wing****	O'Driscoll & Grove, Inc.	W-7421-eng-39	4-29-44	7-1
Nurses' Home	Foster & Creighton Company	W-7415-eng-7	7-6-43	10-1
Nurses' Dormitory	Clinton Home Builders	W-7415-eng-51	4-1-43	6-2
Dental Clinic	John A. Johnson Contracting Corp.	W-7418-eng-159	5-29-44	7-2
Storage Bldg., Inflan. Gases	Stone & Webster Engr. Corp.	W-7401-eng-13	3-27-44	5-1
Field Hospitals*****	Stone & Webster Engr. Corp.	W-7401-eng-13	7-15-43	8-2
Alterations, Psychiatric Ward	Roane-Anderson Company	W-7401-eng-115	5-10-45	7-1
Alterations, Dental Clinic	Roane-Anderson Company	W-7401-eng-115	3-24-45	5-1
Addition to Kitchen	Roane-Anderson Company	W-7401-eng-115	3-22-45	5-3
Emergency & Receiving Entrance	Clinton Construction Co.	W-22-075-eng-112	7-23-45	11-1
Veterinary Building				
Practitioners' Offices, Dental Clinic	Roane-Anderson Company	W-7401-eng-115	1946	1946
Colored Dentist's Office	Roane-Anderson Company	W-7401-eng-115	1946	1946

Actual Cost Sub-Total

Gamble Valley Dispensary (Closed)
K-25 Area Dispensary (Closed)

Estimated
Estimated

Estimated Cost Sub-Total

ACTUAL AND ESTIMATED TOTAL, MEDICAL FACI

*Order: Month, day, year. Contract dates only.

**For sources of cost data, see Apps. A-193, A-196, A-306, and contracts shown.

***Subsequently converted to use as District Communications Building.

****Name subsequently changed to Medical Arts Building.

*****Subsequently converted to use as Public Health Center.

CONTRACT DATA, SCHOOL AND MEDICAL FACILITIES

THROUGH 31 DECEMBER 1946

	CONTRACT NO.	DATE* STARTED	DATE* COMPLETED	COST**
gr. Corp.	W-7401-eng-13	8-20-43	11-20-43	\$ 35,520.05
Company	W-7415-eng-9	7-13-43	11-18-43)	
Contracting Corp.	W-7418-eng-161	7-10-44	9-10-44)	747,503.66
Company	W-7415-eng-11	8-3-43	11-15-43)	
Company	W-7415-eng-11	10-11-43	12-3-43)	1,014,094.75
Company	W-7415-eng-11	8-3-43	11-8-43)	
, Inc.	W-7415-eng-52	3-23-43	7-9-43	283,898.16
Contracting Corp.	W-7418-eng-158	5-29-44	8-27-44	217,791.49
gr. Corp.	W-7401-eng-13	8-11-43	1-19-44	19,106.23
Contracting Corp. and	W-7418-eng-162)			
gr. Corp.	W-7401-eng-13)	8-1-44	11-10-44	580,879.13
Contracting Corp.	W-14-108-eng-65	5-17-45	12-4-45	255,674.84
agerty	W-22-075-eng-127	10-11-45	12-28-45	91,225.07
Contracting Corp.	W-14-108-eng-69	6-26-45	11-27-45)	
Contracting Corp.	W-14-108-eng-69	6-26-45	11-22-45)	277,238.88
Contracting Corp.	W-14-108-eng-69	6-26-45	11-22-45)	
ervation; built by Anderson County, 1939, with Federal Funds.				
	W-22-075-eng-114	7-28-45	12-6-45)	
	W-22-075-eng-114	7-28-45	12-6-45)	96,735.54
	W-22-075-eng-114	7-28-45	12-6-45)	
Contracting Corp.	W-17-028-eng-132	1946	1946)	44,679.00
Contracting Corp.	W-17-028-eng-132	1946	1946)	
	Actual Cost Sub-Total			\$ 3,664,346.80
uction Co.	1944 (Estimated Cost)			200,000.00
	ACTUAL AND ESTIMATED TOTAL, SCHOOL FACILITIES			\$ 3,864,346.80

	CONTRACT NO.	DATE* STARTED	DATE* COMPLETED	COST**
gr. Corp.	W-7401-eng-13	3-3-43	6-8-43	\$ 168,771.33
Company	W-7415-eng-5	6-17-43	11-9-43)	
on	W-7401-eng-167	3-16-44	10-20-44)	993,634.01
, Inc.	W-7421-eng-31	4-29-44	8-19-44)	
pany	W-7401-eng-115	3-1-45	Not available	80,680.39
, Inc.	W-7421-eng-39	4-29-44	7-16-44)	185,769.11
Company	W-7415-eng-7	7-6-43	10-16-43	69,431.58
ers	W-7415-eng-51	4-1-43	6-21-44)	102,974.64
Contracting Corp.	W-7418-eng-159	5-29-44	7-26-44)	96,053.18
gr. Corp.	W-7401-eng-13	3-27-44	5-1-44)	1,358.61
gr. Corp.	W-7401-eng-13	7-15-43	8-29-43)	50,617.00
pany	W-7401-eng-115	5-10-45	7-14-45)	15,362.69
pany	W-7401-eng-115	3-24-45	5-17-45)	4,272.48
pany	W-7401-eng-115	3-22-45	5-30-45)	17,784.16
m Co.	W-22-075-eng-112	7-23-45	11-1-45)	20,332.90
				5,051.91
pany	W-7401-eng-115	1946	1946	11,147.69
pany	W-7401-eng-115	1946	1946	1,398.33
	Actual Cost Sub-Total			\$ 1,824,640.01
	Estimated			\$ 2,500.00
	Estimated			2,500.00
	Estimated Cost Sub-Total			\$ 5,000.00
	ACTUAL AND ESTIMATED TOTAL, MEDICAL FACILITIES			\$ 1,829,640.01

and contracts shown.
Building.

0-7 ELECTRIC POWER CONSUMPTION AND COSTS, CEW

ELECTRIC POWER CONSUMPTION AND COSTS

CLINTON ENGINEER WORKS

OCTOBER 1943 THROUGH DECEMBER 1946

<u>Period</u> <u>Ending</u>	<u>KWH</u> <u>Consumed</u>	<u>KW</u> <u>Demand</u>	<u>Total</u> <u>Costs</u>
1 November 1943	3,912,040	11,400	\$ 18,834.08
1 December 1943	9,105,000	18,300	34,171.50
1 January 1944	8,365,000	18,300	33,061.50
1 February 1944	10,725,000	23,100	41,785.50
1 March 1944	17,105,000	31,200	60,103.50
1 April 1944	27,665,000	48,600	94,735.50
1 May 1944	33,970,000	64,500	121,365.00
1 June 1944	41,478,000	73,800	142,671.00
1 July 1944	39,870,000	98,200	166,611.00
1 August 1944	46,140,000	104,200	182,496.00
1 September 1944	52,610,000	125,900	215,637.00
1 October 1944	63,280,000	144,450	251,676.00
1 November 1944	77,700,000	187,760	320,080.80
1 December 1944	90,370,000	222,050	376,119.00
1 January 1945	107,010,000	236,900	417,117.00
1 February 1945	123,668,000	242,633	448,295.64
1 March 1945	117,442,000	253,047	450,203.76
1 April 1945	150,950,000	290,487	540,900.96
1 May 1945	166,170,000	263,626	534,721.08
1 June 1945	179,160,000	269,866	560,945.28
1 July 1945	184,350,000	283,840	583,822.20
1 August 1945	198,870,000	291,800	614,199.00
1 September 1945	200,000,000	298,627	623,267.16
1 October 1945	117,920,000	292,867	493,926.36
1 November 1945	60,290,000	116,227	216,710.16
1 December 1945	48,020,000	122,347	204,914.76
1 January 1946	63,620,000	145,100	252,888.00
1 February 1946	96,587,000	197,540	358,973.70
1 March 1946	113,130,000	220,040	408,088.20
1 April 1946	150,550,000	258,440	505,690.20
1 May 1946	162,400,000	266,127	531,767.16
1 June 1946	171,995,000	261,463	541,122.54
1 July 1946	181,253,000	293,867	590,005.86
1 August 1946	180,771,000	293,200	588,562.50
1 September 1946	167,232,000	259,600	531,966.00
1 October 1946	155,725,000	227,200	479,713.50
1 November 1946	178,100,000	267,600	556,908.00
1 December 1946	154,547,000	259,200	512,506.50
1 January 1947	153,739,000	230,400	480,190.50

SECRET

C-8 SCHEDULE OF HOUSING RENTAL RATES (2 Sheets)

CENTRAL FACILITIES

SCHEDULE OF HOUSING RENTAL RATES, 31 DECEMBER 1946

<u>TYPE</u>	<u>RENT</u>	<u>TYPE</u>	<u>RENT</u>	<u>TYPE</u>
<u>CONCRETE UNITS*</u>	<u>PER MONTH</u>	<u>MULTI-FAMILY UNITS*</u>	<u>PER MONTH</u>	<u>PREFABRICATED UNITS*</u>
"A"	\$38.00	"K" (Two bedrooms)	\$37.00	A-6
"B"	48.50	"K" (One bedroom)	31.50	B-1
"C"	56.00	"L" (Three bedrooms)	43.00	C-1
"D"	68.50	"L" (Two bedrooms)	36.00	"V"
"D-D"	72.00	"N"	30.00 (\$42.00)	"S"
"E" (One bedroom)	33.00 (\$45.00)	"T" (Three bedrooms)	37.00	
"F" (Two bedrooms)	40.00 (\$55.00)	"T" (Two bedrooms)	32.00	<u>DORMITORY APARTMENTS**</u>
"G"	73.00	"U"	32.00	"H"
"G"	32.00			One bedroom, small living room
"H"	40.00	<u>DEMOUNTABLE UNITS*</u>	<u>PER MONTH</u>	One bedroom, large living room
		One bedroom	\$23.00	One bedroom, large living room, and porch
<u>APARTMENTS**</u>	<u>PER MONTH</u>	Two bedrooms	30.00	Two bedrooms, small living room
Types 1A and 1B		Three bedrooms	34.00	Two bedrooms, large living room
One bedroom	\$50.00			
Two bedrooms	75.00	<u>VICTORY COTTAGES***</u>	15.00 (\$17.50)	"S" (Converted)
Type 2	40.00			"S" (Original)

CENTRAL FACILITIES

SCHEDULE OF HOUSING RENTAL RATES, 31 DECEMBER 1946

<u>RENT</u>	<u>TYPE</u>	<u>RENT</u>	<u>TYPE</u>	<u>RENT</u>
<u>PER MONTH</u>	<u>MULTI-FAMILY UNITS*</u>	<u>PER MONTH</u>	<u>PREFABRICATED UNITS*</u>	<u>PER MONTH</u>
\$38.00	"K" (Two bedrooms)	\$37.00	A-6	\$25.75 (\$28.75)
48.50	"K" (One bedroom)	31.50	B-1	34.25 (\$37.75)
56.00	"L" (Three bedrooms)	43.00	C-1	40.00
68.50	"L" (Two bedrooms)	36.00	"V"	32.25
72.00	"M"	30.00 (\$42.00)	"S"	25.75
ocm) 33.00 (\$45.00)	"T" (Three bedrooms)	37.00		
ocms) 40.00 (\$55.00)	"T" (Two bedrooms)	32.00	<u>DORMITORY APARTMENTS**</u>	<u>PER MONTH</u>
73.00	"U"	32.00	"H"	
32.00			One bedroom, small living room	\$45.00
40.00	<u>DEMOUNTABLE UNITS*</u>	<u>PER MONTH</u>	One bedroom, large living room	50.00
	One bedroom	\$23.00	One bedroom, large living room, and porch	52.50
<u>PER MONTH</u>	Two bedrooms	30.00	Two bedrooms, small living room	55.00
	Three bedrooms	34.00	Two bedrooms, large living room	60.00
\$50.00			"S" (Converted)	40.00
75.00	<u>VICTORY COTTAGES***</u>	15.00 (\$17.50)	"S" (Original)	30.00
40.00				

SCHEDULE OF HOUSING RENTAL RATES (Cont'd)

<u>TYPE</u>	<u>RENT</u>	<u>TYPE</u>	<u>RENT</u>	<u>TYPE</u>
<u>DORMITORY ROOMS**</u>	<u>PER MONTH</u>	<u>TRAILERS****</u>	<u>PER MONTH</u>	<u>HUTMENTS***</u>
Single	\$15.00	Single	\$15.00	Family
Double	10.00	Double	20.00	Single
Double (Single occupancy)	25.00	Private trailer lot	10.00	Double
				Individuals
<u>FARM H USES</u>	\$12.00 to \$50.00	<u>HUTMENT APARTMENTS</u>	\$25.00****	

*Fuel and utilities included in rent. Rental with furniture is shown in parentheses; other Cessna, Multi-P, Prefabricated, and Demountable units are not furnished.

**Fuel, utilities, and furniture included in rent.

***Utilities and furniture, but not fuel, included in rent.

****Utilities and built-in furniture, but not fuel, included in rent.

*****Utilities and fuel, but not furniture, included in rent.

SCHEDULE OF HOUSING RENTAL RATES (Cont'd)

<u>RENT</u>	<u>TYPE</u>	<u>RENT</u>	<u>TYPE</u>	<u>RENT</u>
<u>PER MONTH</u>	<u>TRAILERS***</u>	<u>PER MONTH</u>	<u>FLATMENTS***</u>	<u>PER WEEK</u>
\$15.00	Single	\$15.00	Family	
10.00	Double	20.00	Single	\$3.00
25.00	Private trailer lot	10.00	Double	4.00
			Individuals	1.40
\$12.00 to \$50.00	<u>FLATMENT APARTMENTS</u>	\$25.00****		

Utilities included in rent. Rental with furniture is shown in parentheses; other Casemato, Multi-Family, and Demountable units are not furnished.

Utilities, and furniture included in rent.

Utilities and furniture, but not fuel, included in rent.

Utilities and built-in furniture, but not fuel, included in rent.

Utilities and fuel, but not furniture, included in rent.

**C-8a SEWERAGE SYSTEM, QUANTITIES AND UNIT COSTS,
1944, 1945, AND 1946**

CENTRAL FACILITIES

SEWAGE TREATMENT, QUANTITIES AND UNIT COSTS, 1944, 1945, AND 1946

<u>MONTH</u>	<u>TREATMENT PLANT NO. 1</u>		<u>TREATMENT PLANT NO. 2*</u>	
	<u>Average MGD Handled</u>	<u>Unit Cost Per MG</u>	<u>Average MGD Handled</u>	<u>Unit Cost Per MG</u>
<u>1944</u>				
January	1.400	\$66.07		
February	2.100	72.05		
March	1.932	71.80		
April	2.103	72.48		
May	3.260	67.08		
June	2.606	69.94	2.658	\$49.79
July	2.035	70.98	3.278	46.07
August	2.174	53.49	3.430	37.58
September	1.800	80.45	3.844	32.78
October	1.561	75.70	4.134	30.88
November	1.600	75.51	4.150	29.36
December	1.607	68.95	4.049	26.95
<u>1945</u>				
January	1.751	56.50	4.463	20.03
February	1.862	58.89	4.669	21.14
March	1.575	69.05	4.558	26.53
April	1.625	70.14	4.168	23.57
May	1.483	60.39	4.992	19.83
June	1.572	68.65	5.003	18.88
July	1.524	71.16	4.512	22.60
August	1.685	66.92	4.776	22.37
September	1.557	71.71	4.526	27.29
October	1.551	64.29	4.438	28.07
November	1.644	60.49	4.606	23.36
December	1.824	48.87	5.189	19.11
<u>1946</u>				
January	2.079	64.61	5.169	19.33
February	1.852	54.06	5.244	18.50
March	1.724	60.64	4.767	20.08
April	1.461	66.00	4.206	28.51
May	1.573	71.10	4.673	21.16
June	1.488	65.86	4.240	23.29
July	1.554	46.99	4.208	22.53
August	1.508	49.96	4.016	24.41
September	1.563	45.37	4.083	24.89
October	1.564	47.68	4.011	23.09
November	1.635	48.35	4.311	20.51
December	1.755	52.63	3.894	18.33

*Plant No. 2 began operations 30 May 1944.

Source: Monthly Reports of Facilities Activities, Roane-Arderson Company.

**C-8b WATER SUPPLY SYSTEM, QUANTITIES AND UNIT COSTS,
1944, 1945, AND 1946**

CENTRAL FACILITIES

WATER SUPPLY SYSTEM, QUANTITIES AND UNIT COSTS 1944, 1945, AND 1946

<u>MONTH</u>	<u>AVERAGE MGD PUMPED</u>	<u>AVERAGE MGD TREATED</u>	<u>UNIT COST OF PUMPING PER MG</u>	<u>UNIT COST OF FILTER- ING PER MG</u>
<u>1944</u>				
January	4.531	3.691	\$24.96	\$36.26
February	4.919	4.261	44.91	50.50
March	4.970	4.765	39.03	41.64
April	6.269	5.711	33.09	38.26
May	8.966	7.593	20.77	30.91
June	9.585	7.863	19.19	28.32
July	9.751	7.527	19.53	26.63
August	8.961	7.595	23.82	20.72
September	8.868	7.725	19.88	23.42
October	9.800	8.351	16.66	20.90
November	11.553	8.903	12.63	22.04
December	11.502	9.754	12.93	17.91
<u>1945</u>				
January	10.863	9.742	14.28	17.82
February	13.433	12.315	13.87	14.81
March	13.554	12.064	11.61	14.12
April	15.044	13.339	9.54	12.45
May	16.045	14.353	9.51	14.49
June	16.241	14.654	9.86	14.96
July	17.416	15.333	11.20	13.79
August	18.143	16.141	9.80	14.14
September	14.007	12.346	11.32	18.36
October	11.201	10.461	15.94	17.23
November	10.878	10.249	18.28	21.07
December	10.730	10.421	14.82	17.84
<u>1946</u>				
January	10.016	9.777	20.00	20.72
February	9.635	9.349	17.11	18.43
March	9.191	8.974	19.37	22.99
April	9.413	9.006	17.71	17.55
May	9.397	8.934	18.83	17.90
June	9.744	9.282	16.77	18.95
July	10.329	9.848	7.91	16.83
August	9.686	9.003	8.37	17.63
September	9.258	8.734	9.95	15.20
October	8.898	8.338	12.67	18.53
November	8.990	8.347	16.74	21.00
December	8.091	8.265	10.28	22.55

Source: Monthly Reports of Facilities Activities, Reane-Anderson Company.

C-9 BUS OPERATIONS, CEM, FEBRUARY 1944 THROUGH DECEMBER
1946

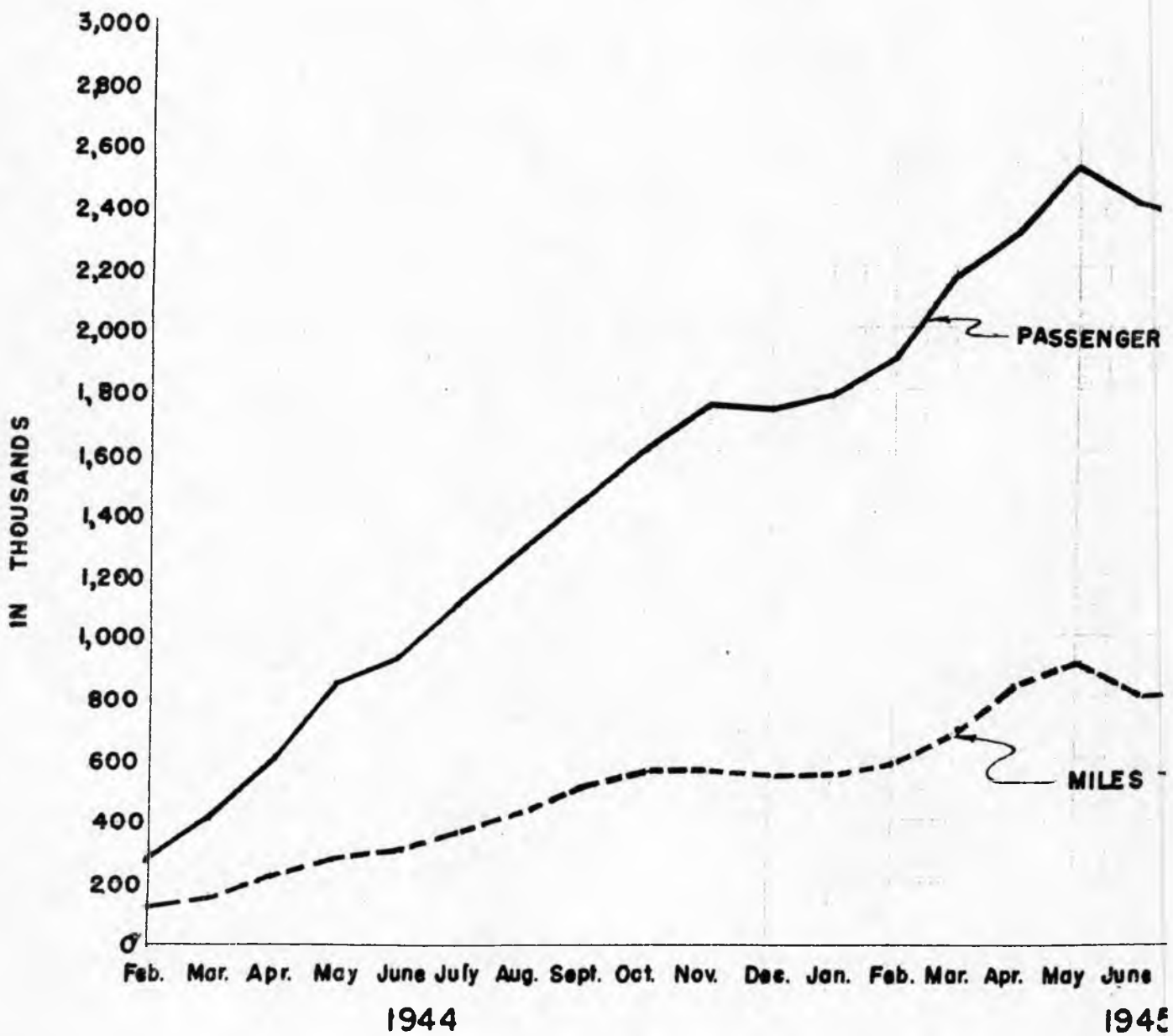

C9-1

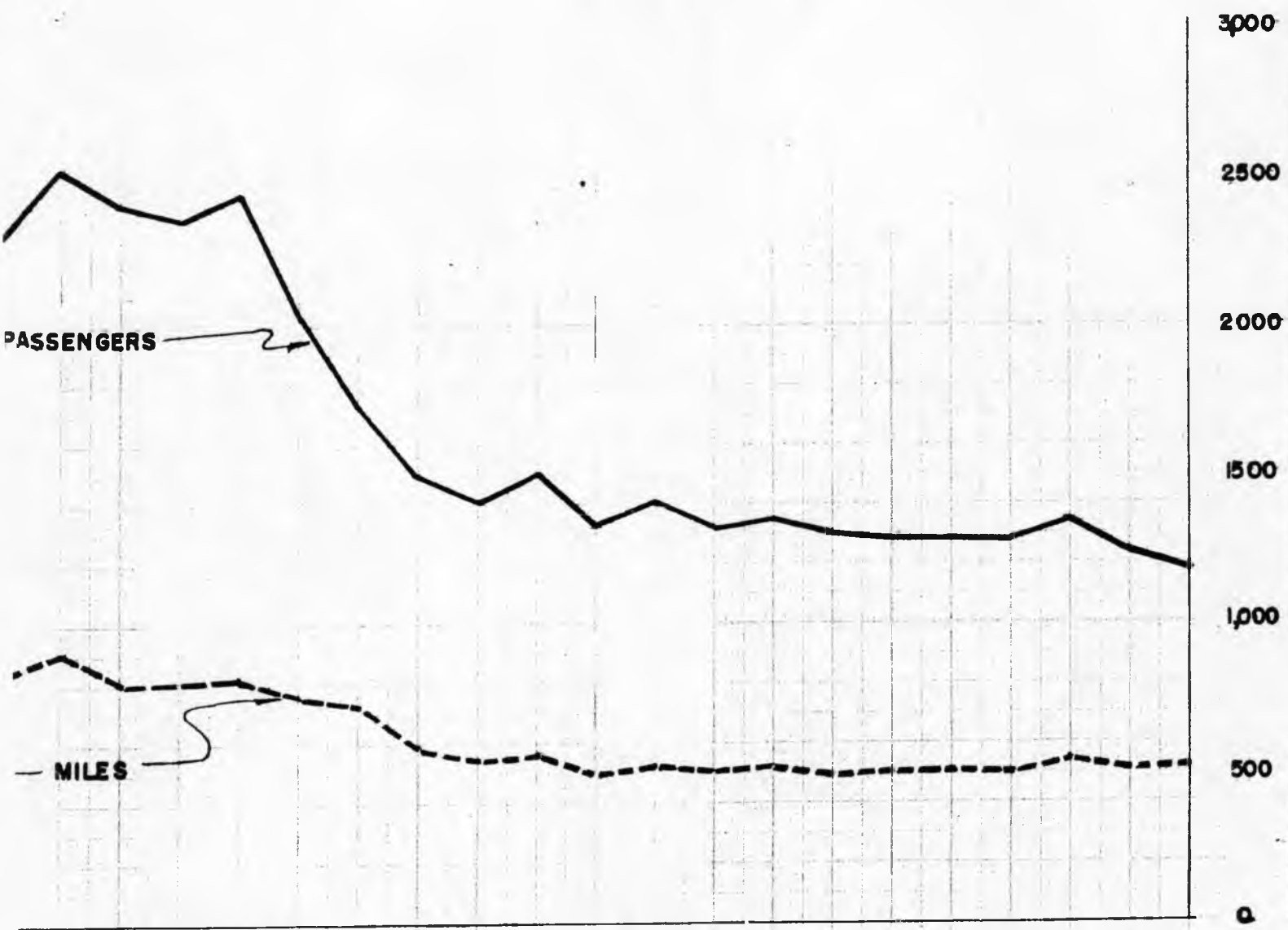

May June July Aug Sept. Oct. Nov. Dec. Jan. Feb, Mar. Apr. May June July Aug. Sept. Oct. Nov Dec.
 1945 1946

**BUS TRANSPORTATION
 AREA OPERATIONS**

AREA BUS OPERATIONS

February 1944 through December 1946

	<u>MONTH</u>	<u>NO. OF BUSES</u>	<u>MILES</u>	<u>PASSENGERS</u>
	1944			
	FEBRUARY	67	128,323	289,465
	MARCH	122	163,254	424,468
	APRIL	163	229,335	604,055
3000	MAY	162	281,838	853,955
	JUNE	193	304,930	934,507
	JULY	206	374,024	1,114,150
	AUGUST	218	429,806	1,277,685
	SEPTEMBER	247	513,135	1,455,111
2500	OCTOBER	274	564,892	1,612,344
	NOVEMBER	261	566,374	1,749,813
	DECEMBER	267	554,526	1,739,338
	1945			
	JANUARY	315	553,172	1,780,720
	FEBRUARY	263	584,789	1,906,273
2000	MARCH	337	676,976	2,174,772
	APRIL	350	843,234	2,298,263
	MAY	331	908,359	2,531,281
	JUNE	392	812,395	2,401,070
	JULY	404	815,121	2,359,415
1500	AUGUST	420	828,418	2,434,568
	SEPTEMBER	375	758,704	2,035,783
	OCTOBER	357	731,312	1,734,552
	NOVEMBER	280	597,178	1,502,166
	DECEMBER	270	550,872	1,413,297
	1946			
1,000	JANUARY	257	566,754	1,500,953
	FEBRUARY	245	500,931	1,323,772
	MARCH	210	530,868	1,421,346
	APRIL	211	507,387	1,315,645
	MAY	210	526,900	1,353,335
500	JUNE	194	490,603	1,273,132
	JULY	194	514,226	1,288,379
	AUGUST	194	517,628	1,281,098
	SEPTEMBER	210	507,040	1,279,586
	OCTOBER	210	546,502	1,356,890
	NOVEMBER	209	510,645	1,234,483
0	DECEMBER	209	520,483	1,175,228

IN THOUSANDS

Dec.

STATION
IONS

C-10 BUS OPERATIONS, OFF-AREA, FEBRUARY 1944 THROUGH

DECEMBER 1946

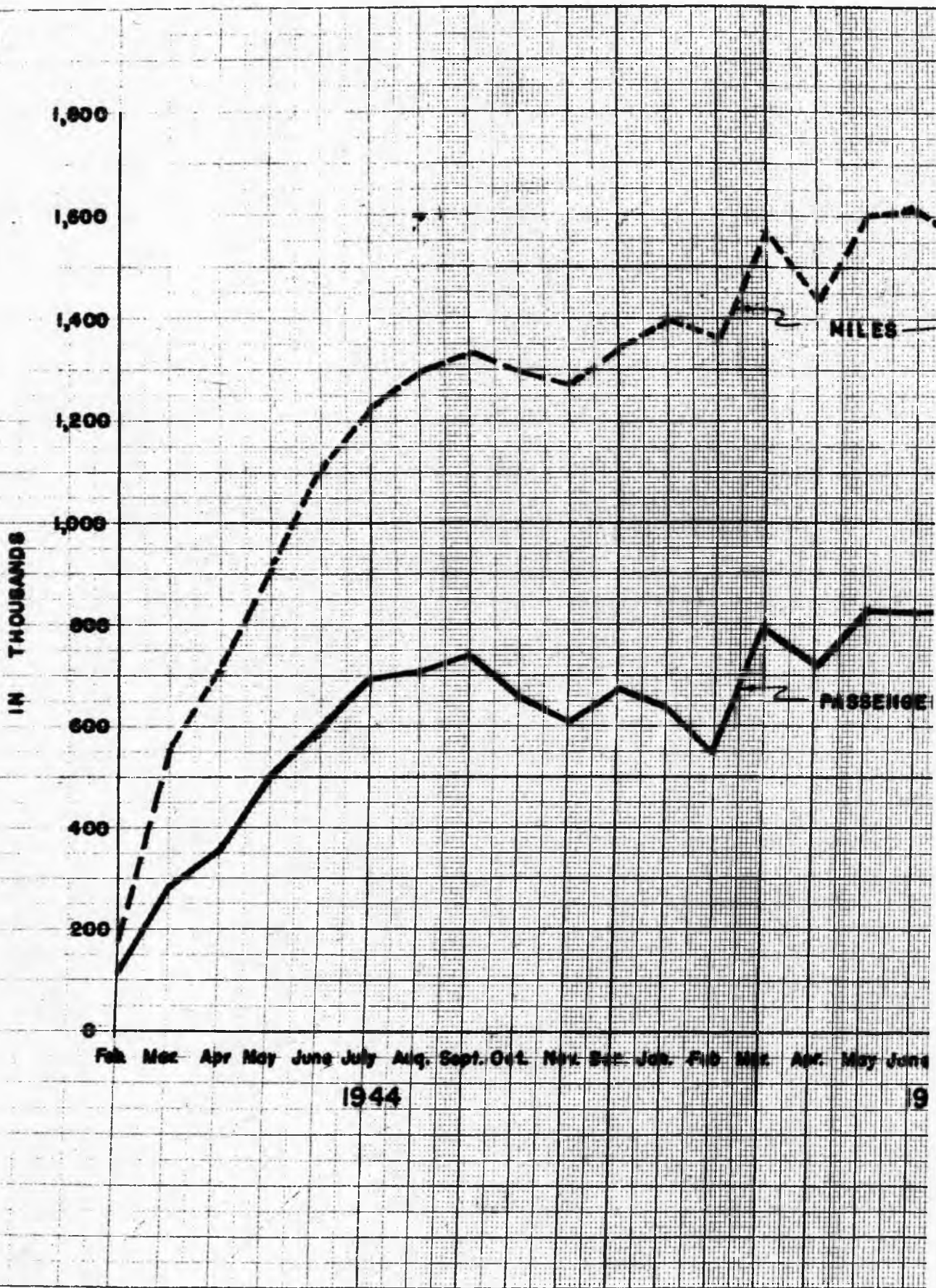

C10-1

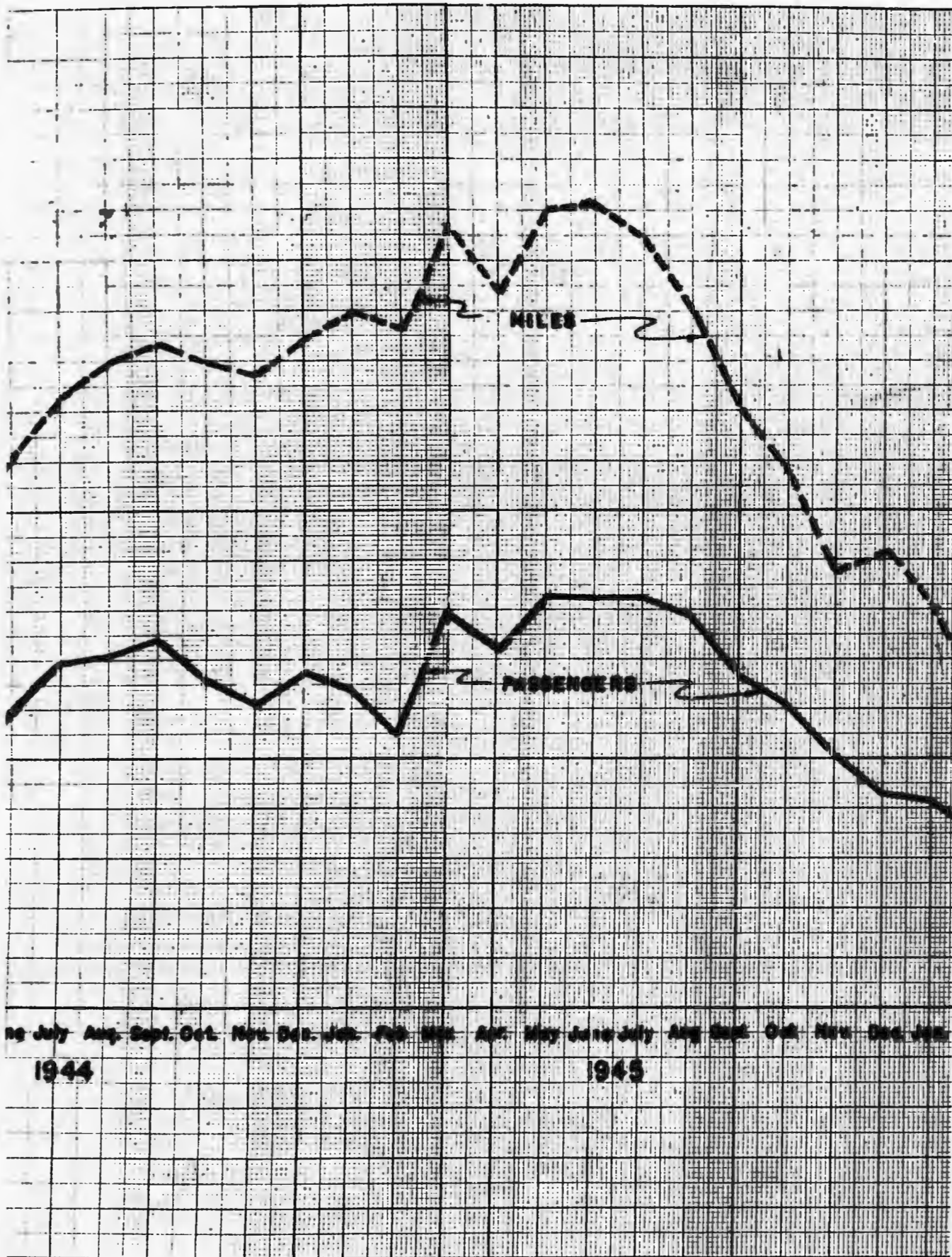

C10-7

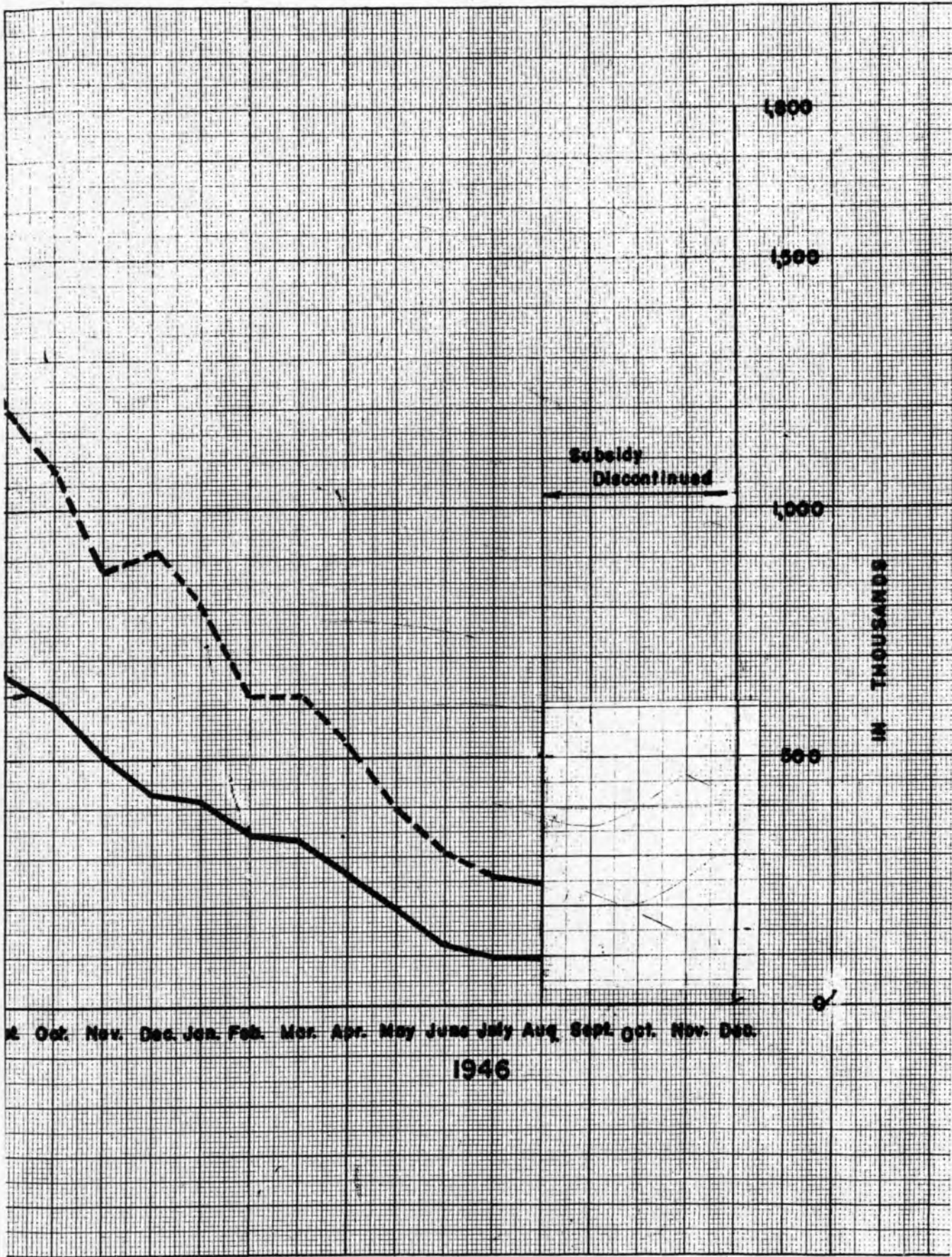

C10-2a

OFF AREA BUS OPERATIONS

<u>MONTH</u>	<u>BUSES</u>		<u>TOTAL</u>	<u>MILES</u>	<u>PASSENGERS</u>
	** P/O	* O/O			
<u>1944</u>					
FEBRUARY	80	54	134	184,036	114,935
MARCH	98	115	213	556,686	289,232
APRIL	98	150	248	710,464	355,064
MAY	104	173	277	907,028	503,406
JUNE	105	198	303	1,108,330	590,872
JULY	132	219	351	1,229,551	697,288
AUGUST	131	221	352	1,296,828	710,854
SEPTEMBER	133	223	356	1,328,292	736,887
OCTOBER	133	224	357	1,295,364	653,255
NOVEMBER	133	224	357	1,272,622	608,175
DECEMBER	133	224	357	1,342,016	675,940
<u>1945</u>					
JANUARY	133	230	363	1,395,257	637,269
FEBRUARY	139	242	381	1,360,589	547,354
MARCH	141	236	377	1,567,829	795,426
APRIL	129	212	341	1,438,873	727,200
MAY	148	232	380	1,599,303	829,985
JUNE	160	266	426	1,601,885	827,782
JULY	168	269	437	1,535,956	828,574
AUGUST	188	328	516	1,395,733	789,551
SEPTEMBER	157	253	410	1,195,789	664,278
OCTOBER	164	220	384	1,078,216	601,606
NOVEMBER	148	218	366	881,024	502,090
DECEMBER	146	215	361	814,319	427,789
<u>1946</u>					
JANUARY	139	208	347	802,383.9	417,706
FEBRUARY	108	183	291	623,814.7	344,794
MARCH	97	170	267	629,128.8	336,988
APRIL	84	140	224	524,027.2	269,566
MAY	66	110	176	391,236.9	195,869
JUNE	60	111	171	305,645.3	125,985
JULY	100	91	191	255,684.0	99,294
AUGUST	102	98	200	241,424.6	95,476

** Privately owned

* Government owned

BUS TRANSPORTATION
OFF AREA OPERATIONS
SUBSIDY CONTRACTS

**G-10a OFF-AREA EIS SUBSIDY CONTRACTORS, COMMUNITIES SERVED,
AND CONTRACT TERMINATION DATES**

CENTRAL FACILITIES

OFF-AREA BUS SUBSIDY CONTRACTORS, COMMUNITIES SERVED,

<u>Contractors</u>	<u>Communities Served (1)</u>
Brimer Bus Line	Jellico and Lake City
Cherokee Motor Coach Company	Big Spring, Dayton, Decatur, Harriman, Knoxville, R
Coker Bus Line (2)	Deer Lodge, Oliver Springs, Stainsville, Sunbright,
Elk Valley Bus Line	Elk Valley and Jellico
Fox Bus Line (3)	Briceville, Huntsville, Lake City, and Pioneer
Holston Coach Company	Jefferson City
Knoxville Transit Lines (4)	Knoxville
LaFollette Coach Lines (5)	Cumberland Gap, Jacksboro, LaFollette, and Speedwell
Lenoir City - Alcoa Bus Line (6)	Englewood, Lenoir City, Madisonville, and Vonore
Local Bus Lines (7)	Knoxville and Seven Islands
Local Transit Lines (7)	Knoxville and Seven Islands
Medlin Bus Lines	Athens, Decatur, and Etowah
Montgomery Bus Line (3)	Deer Lodge, Jamestown, Huntsville, Oneida, Pioneer,
Morgan Bus Line	Clifty, Crossville, Dayton, Grimsley, Monterey, and
Owen Bus Line (8)	Belmont, Loyston, Norris, and Norris Dam
Payne-Richardson Bus Line	Jefferson City, Morristown, Newport, Piedmont, Rutle
Randolph Bus Line (9)	Cumberland Gap, LaFollette, and Speedwell
Sexton Bus Line	Maynardville
Smith Bus Line	Maryville and Wildwood
Smoky Mountain Stages, Inc.	Gatlinburg, Knoxville, Sevierville, and Pigeon Forge
Tennessee Coach Company	Knoxville and Rockwood
Wilhite Bus Line	Erie, Loudon, Madisonville, Sweetwater, and Tellico

- (1) All points shown are in Tennessee; service to all points shown was not necessarily per
- (2) Name subsequently changed to Oliver Springs Bus Lines; contract termination was under
- (3) Fox Bus Line extended to Huntsville after termination of contract with Montgomery Bus
- (4) Knoxville Transit Lines furnished local "owl" service to meet CEW busses in Knoxville.
- (5) LaFollette Coach Lines was purchased and operated commercially by Baker Bus Line after
- (6) Also known as Clark Bus Line.
- (7) Local Bus Lines sold to Cherokee Motor Coach Lines in 1945; operator reentered service
- (8) Owen Bus Line was purchased and operated commercially by Norris Motor Company after te
- (9) Randolph Bus Line was purchased by LaFollette Coach Lines.

RAIL FACILITIES

SERVICES SERVED, AND CONTRACT TERMINATION DATES

Contract Termination Dates

in, Knoxville, Rockwood, and Spring City

12 August 1945

1 June 1946

ville, Sunbright, and Wartburg

1 May 1946

16 September 1945

and Pioneer

1 July 1946

18 June 1944

2 September 1945

e, and Speedwell

1 April 1946

, and Vonore

1 June 1946

(See Note 7, below)

1 September 1946

neida, Pioneer, and Winfield

16 April 1946

, Monterey, and Spring City

5 August 1945

Dam

1 May 1946

Piedmont, Rutledge, Tazewell, Thorn Hill, and White Pine

16 June 1946

Speedwell

13 August 1945

and Pigeon Forge

31 March 1945

1 February 1946

or, and Tellico Plains

1 April 1946

19 June 1946

1 September 1946

1 June 1946

necessarily performed simultaneously.

tion was under latter name.

Montgomery Bus Line.

s in Knoxville.

Bus Line after termination of LaFollette's contract.

ntered service in 1946 under name of Local Transit Lines.

mpany after termination of Owen's contract.

**C-10b OPERATIONAL COSTS, BUS SYSTEM, AIT, FEBRUARY 1945
THROUGH DECEMBER 1946**

CENTRAL FACILITIES

OPERATIONAL COSTS, BUS SYSTEM, AIT, FEBRUARY 1945 - DECEMBER 1946

<u>Purpose</u>	<u>Area</u>	<u>Off-Area</u>	<u>Non-Chargeable</u>
Equipment, Maintenance, and Garage Expense	\$ 1,437,601	\$ 14,026	\$ 102,958
Transportation	2,754,772	4,820,435	16,851
Station Expense	126,350	16,804	58,476
Traffic and Advertising Expense	49,501	35,335	41
Insurance and Safety	205,649	16,148	371
Administration and General Expense*	620,779	239,949	104,405
Operating Taxes and Licenses	213,272	25,958	103,725
Rental and Operating Property	4,321		
Depreciation	<u>523,928</u>		
Total Operating Costs	\$ 5,966,173	\$ 5,198,655	\$ 386,827
Revenue	<u>1,744,691</u>	<u>1,971,743</u>	
Net Operating Costs	<u>\$ 4,221,482</u>	<u>\$ 3,226,912</u>	<u>\$ 386,827</u>
Incentive and Fixed Fees Apportioned	\$ 172,500	\$ 57,500	\$ 91,736

*Includes incentive and fixed fees.

**Includes net cash cost to Government of \$6,343,497.

OPERATIONAL COSTS, BUS SYSTEM, AIT, FEBRUARY 1945 - DECEMBER 1946

<u>Purpose</u>	<u>Area</u>	<u>Off-Area</u>	<u>Non-Chargeable</u>	<u>Total</u>
Ice, and Garage Expense	\$ 1,137,601	\$ 14,026	\$ 102,958	\$ 1,554,585
	2,754,772	4,820,435	16,851	7,592,058
	126,350	16,804	58,476	231,630
Printing Expense	19,501	35,335	41	84,877
	205,649	16,148	371	222,168
General Expense*	620,779	239,919	104,405	965,133
Licenses	243,272	25,958	103,725	372,955
Property	4,321			4,321
	<u>523,928</u>			<u>523,928</u>
Costs	\$ 5,966,173	\$ 5,198,655	\$ 386,827	\$11,551,655
	<u>1,744,691</u>	<u>1,971,743</u>		<u>3,716,434</u>
Costs	<u>\$ 4,221,482</u>	<u>\$ 3,226,912</u>	<u>\$ 386,827</u>	<u>\$ 7,835,221**</u>
Ad Fees Apportioned	\$ 172,500	\$ 57,500	\$ 91,736	\$ 321,736

and fixed fees.

cost to Government of \$6,343,497.

**C-11 ADMINISTRATIVE, SERVICE, AND MISCELLANEOUS
BUILDINGS AND FACILITIES**

<u>BUILDING NO.</u>	<u>TITLE</u>
1704	Main Administration Building
1708	Employment Office (Now Recreation & Welfare Association Office)
1759-1-4	Roane-Anderson Company Offices
R-A 1923	Personnel Building & Boiler House
1924-T	Exit Interview Office
1925	Roane-Anderson Personnel Building
1922	Clock Alleys T-1-9
1850-T	Fire, Police, & Town Administration (Now Town Hall and Fire Headquarters)
1613	Ice House
1981-T-1	Ice House, Middletown
1615	Cold Storage Building
1758-1	Roane-Anderson Equipment Repair Shop
0101	Ore Storage Warehouse (5 units)
1852-T	Coal Office and Scale
1917	Warehouses 1 to 13
1918	Warehouses, Series M
1919	Warehouses, Series G
1920	Warehouses, Series C
1701-A & B	Clock Alleys & Examination Bldg., (Now Central Bus Terminal & Repair Shop)

*Except as otherwise noted, cost data
 **Source: Apps. A-306, A-307, and A-3
 ***Source: Apps. A-306, A-307, and A-3
 ****Source: Apps. A-306, A-307, and A-3
 #Source: Apps. A-306, A-307, and A-3

CENTRAL FACILITIES

ADMINISTRATIVE, SERVICE, AND MISCELLANEOUS BUILDINGS AND FACILITIES

THROUGH 31 DECEMBER 1946

	<u>COST*</u>	<u>BUILDING NO.</u>	
ing	\$ 811,909.14	1921	Canteen
recreation & (ice)	102,218.51	1938	Lumber
ffices	134,382.67	2715	Stock
er House	128,792.80	1881-T	Coal Ya
	7,777.71	1903-T-1	Informa
Building	7,127.37	1941-T-1	House
	14,735.41	1934-T-1	Middle
		1401	Boiler
Administration Bldg., (Headquarters)	84,692.46	1304	Colorec
	9,858.39		Steam
	2,697.11	1715	Clock
	190,177.77	1858	Ration
Repair Shop	195,338.04	1751	Utiliti
units)	202,259.29		Public
	15,462.52		Gasolin
	571,785.07	2715	Record
	291,147.33		Office
	335,169.87		Motor
	214,694.16	2714	Photog
Bldg., (Now Repair Shops)	84,881.75		

cost data are from App. A-193,
and A-309.
, and A-310.
, and A-311.
, and A-312.

##Source
###Source

BUILDINGS AND FACILITIES

46

<u>ING NO.</u>	<u>TITLE</u>	<u>COST*</u>
	Canteen Warehouse	\$ 19,228.28
	Lumber Sheds	28,534.14
	Stock and Storage Building	31,559.23
T	Coal Yard, Gamble Valley	45,822.64
T-1	Information Building, Elza Gate	8,443.79
T-1	House and Horse Barn	16,138.03
T-1	Middletown Post Office	11,645.63
	Boiler Plant	563,328.69
	Colored Athletic Field	6,498.36
	Steam Lines to Town Buildings	182,048.00
	Clock Alleys and Laboratory	618,246.12
	Ration Board Building	25,503.38
	Utilities, Office and Shop	94,524.38
	Public Wash Rooms**	10,261.00
	Gasoline Storage Facility***	4,110.16
	Records Retirement Vault****	6,732.39
	Office Machine Repair Shop#	10,823.00
	Motor Pool Service and Repair Shop##	17,317.35
	Photographic Laboratory and Switchboard###	<u>14,018.32</u>
	TOTAL	<u>\$5,119,890.26</u>

##Source: Apps. A-306, A-307, and A-313.
 ###Source: Apps. A-196, A-306, and A-307. Separate costs for the two uses not available, but the greater part of the amount shown was for the Photographic Laboratory.

G-12 CASES HANDLED BY REVIEW BOARD, APRIL 194⁵ THROUGH
DECEMBER 1946

CENTRAL FACILITIES

CASES HANDLED BY REVIEW BOARD

APRIL 1945 THROUGH DECEMBER 1946

<u>MONTH</u>	<u>1945</u>			<u>TOTAL</u>
	<u>TRAFFIC</u>	<u>JUVENILE</u>	<u>OTHER</u>	
April	613	73	630	1316
May	602	76	539	1217
June	557	50	597	1204
July	389	41	399	829
August	593	20	375	988
September	240	50	469	759
October	392	47	531	970
November	163	37	302	502
December	184	29	261	474

<u>MONTH</u>	<u>1946</u>			<u>TOTAL</u>
	<u>TRAFFIC</u>	<u>OTHER</u>	<u>STATE WARRANTS</u>	
January	396	264	28	688
February	187	114	16	317
March	147	173	21	341
April	112	120	17	249
May	257	177	18	452
June	185	195	19	399
July	344	130	23	497
August	404	199	22	625
September	402	192	22	616

May	602	76	539	1217
June	557	50	597	1204
July	389	41	399	829
August	593	20	375	988
September	240	50	469	759
October	392	47	531	970
November	163	37	302	502
December	184	29	261	474

1946

<u>MONTH</u>	<u>TRAFFIC</u>	<u>OTHER</u>	<u>STATE WARRANTS</u>	<u>TOTAL</u>
January	396	264	28	688
February	187	114	16	317
March	147	173	21	341
April	112	120	17	249
May	257	177	18	452
June	185	195	19	399
July	344	130	23	497
August	404	199	22	625
September	402	192	22	616
October	334	177	43	554
November	357	149	36	542
December	292	160	23	475

0-13 CONCESSION REPORT, DECEMBER 1946 (10 Sheets)

CONTRACT NO.	CONCESSIONAIRE	LOCATION	ORIGINAL CONTRACT DATE	ACTUAL OPENING DATE	EXPIRATION DATE	BUILDING VALUATION
<u>AUTOMOTIVE GARAGES, SERVICE STATIONS, ETC.</u>						
1B	Copeland Service Station	Arkansas Avenue	3-15-44	4-27-44	6-30-47	18654.00
2B	Vermont Gateway Gas Station	Vermont & O. R. Tnpks	3-15-44	6-3-44	6-30-47	23000.00
4B	Reeder Meter Service	Calif. & O. R. Tnpks	12-10-43	5-27-44	12-31-47	69489.00
20B	Towansite Service Station	Tenn. & Georgia	8-1-43	9-11-43	6-30-47	35700.00
46B	Gamble Valley Trailer Camp, Gas. Sta.	G. Valley Trailer Camp	4-22-44	10-28-44	6-30-47	2700.00
54B	Middletown (Gas. Sta.) Enterprises	Middletown Section	5-31-44	6-1-44	6-30-47	5180.00
101B	Turnpike Service Station	O.R. Tnpks & Ill. Ave	6-15-45	6-14-45	12-31-47	3100.00
102A	Emery Valley Tire Recap Shop	Emery Valley Road	12-1-45	12-1-45	11-30-47	2100.00
110ZA	Radiator & Brake Repair Shop	Coal Yard Road	12-19-45	2-12-45	12-31-47	1920.00
119A	Sam Herne Company (Auto Accessories)	Middletown Section	1-20-45	2-24-45	1-20-47	5713.00
161	West End Service Station	O.R. Tnpks & La. Ave.	10-1-45	11-20-45	9-30-47	18900.00
162	Pan-American Service Station	O.R. Tnpks & G.V. Rd.	10-15-45	12-6-45	10-14-47	19200.00
163	Claybaugh Wrecker Service	Emery Valley Road	8-10-45	8-10-45	8-9-47 ***	1900.00
169A	Trice Meter Service	O.R. Tnpks & La. Ave.	4-1-46	4-1-46	3-31-47	
170	Aouff's Motor Service	O. R. Tnpks & G.V. Rd.	10-1-45	11-15-45	9-30-47	24400.00
176	Mars & Company	Greve Center	11-15-45	11-15-45	11-14-47	
184A	Tweed & Nichols Garage	Gamble Valley Section	11-1-45	11-1-45	3-14-47	
200A	Community Garage	W. Oak Ridge, K-25	1-15-46	1-15-46	10-31-46 ***	
201	Kelse's Motor Tune-Up Service	Tenn. & Tacoma	2-11-45	2-11-45	2-10-47	
213	Crowe & O'Conner Auto Service	Farm Market Area	4-1-46	4-1-46	3-31-47	
225	Harriman Oil Company	Scarboro & Bear Crk. Rd.	9-1-46	9-1-46	10-14-47	
L-326	B.S.K. Repair Garage	Emery Valley Road	4-1-46	4-1-46		##

BARBER SHOPS & BEAUTY SHOPS

5A	Pine Valley Beauty Shop	New York & Utah	4-1-44	4-8-44	6-30-47	8340.00
6B	Pine Valley Barber Shop	New York & Utah	1-1-44	1-26-44	11-30-47	7500.00
16B	Sutton's Barber Shop	Jackson Square	8-1-43	8-26-43	6-30-47	8900.00
17A-	Victory Beauty Shop	Jackson Square	7-1-43	10-4-43	6-30-47	8900.00
18B	McCray Barber Shop	Tennessee & Tacoma	3-1-44	3-25-44	6-30-47	7500.00
19B	Je-Al Beauty Shop	Tennessee & Tacoma	3-1-44	3-21-44	6-30-47	8340.00
31B	East Village Barber Shop	Alabama & Arkansas	3-14-44	6-5-44	3-17-47	8300.00
47A	West Town Beauty Parlor	Jefferson Circle	9-1-44	10-11-44	11-30-47	1811.00
56B	Middletown Barber Shop	Middletown Section	7-1-44	7-1-44	6-30-47	3180.00
62B	Thompson Barber & Beauty Shop	Colored Hut Sec. Midtown	6-29-44	6-29-44	5-28-47	3825.00
63A	Allen's Barber Shop	Gamble Valley TR. Camp	3-21-44	9-8-44	11-30-47	3900.00
65A	Jefferson Circle Barber Shop	Jefferson Circle	6-20-44	8-25-44	11-30-47	8070.00
67A	Greve Center Beauty Shop	Greve Center	10-19-44	11-10-44	12-31-47	6420.00
68A	Greve Barber Shop	Greve Center	3-14-44	10-9-44	11-30-47	8281.00
70C	Hilltop Barber Shop	Ill. Ave. & Outer Dr.	11-15-45	12-1-45	11-30-47	
73B	Essie's Beauty Shop	Gamble Valley	6-3-44	9-13-44	1-30-47	

* Delinquent
 ** Not open during current month
 *** Terminated
 ## Revocable at Will
 # Seasonal Operation
 ## Duration Plus 6 Months
 ### Withdrew Before Operating
 ### No Sales Made During Current Month

Note: THIS REPORT IS FOR STATISTICAL PURPOSES AND DOES NOT PURPORT TO REPRESENT CONTROL OF REVENUE.

ERSON COMPANY
 GINER WORKS
 TENNESSEE

MONTHLY RENTALS REPORT

for 1946

<u>GROSS RECEIPTS</u>			RENTAL-PAYMENTS		PERCENTAGE OF RENTALS	
DECEMBER 1946	ADJUSTMENTS	TOTAL TO DATE	DEC. 1946	ADJUSTMENTS	TOTAL TO DATE	OF RENTALS
11602.86		462897.98	586.14		21052.97	5
24779.25	Cr. 6.00	881138.74	543.96	Cr. .30	39646.59	5
45354.05	Cr. 163.30	949449.61	1710.23	Cr. 2.09	46720.21	6 & 2
9790.51		572817.84	489.53		23317.95	5
		224826.01			10175.60	5
9182.43	Cr. 270.58	288759.32	348.20	Cr. 9.93	11551.25	4
20146.36	14.12	459418.78	1061.32	.70	19852.03	5
533.24		14073.88	37.10		910.84	5 & 7
1181.34		43328.17	126.83		4372.41	10
4017.84		106055.46	241.06		5618.06	6 - \$200 Min
		91162.39			7265.30	6
11628.67	Cr. 424.35	152513.96	718.55	Cr. 13.25	11646.69	8
		27075.36			2707.65	10, 6 & 7
2648.90		23577.56	158.93		1310.78	6
3069.79	995.00	60339.04	184.19	36.50	4710.86	6
15630.00		133296.57	1564.13	8.04	13168.07	10
846.42		7361.01	80.01	.01	770.66	10
		22481.16			1601.32	3 & 8
2048.74		20154.92	161.29	1.28	1498.67	10, 3 & 5 - \$100 Min.
3355.05		30223.10	268.40		2417.83	8
9552.04		18434.64				4
			82.61		682.61	15 per Mo.
175167.29	144.89	4589385.60	8374.48	20.96	230998.05	
935.16	.80	40534.42	134.22	.10	4488.78	12
940.50		40990.25	94.06		3501.53	10
4391.35		191523.49	351.31		13234.16	8 & 10
1922.03	20.25	142549.60	230.64	2.43	15338.30	12
1421.50		44996.80	147.50	Cr. .01	4127.82	10 & 12
728.45	Cr. 1.00	35664.77	87.41	Cr. .12	3935.52	12
958.15		30931.37	98.97	Cr. 3.36	3109.30	10 & 12
811.75	6.46	58767.23	97.41	9.84	6212.21	12
1179.15	.60	43904.18	121.79	.06	4469.65	10 & 12
		8081.51	40.00		966.28	\$40 per Mo.
428.40		24742.64	42.55	Cr. .01	2474.36	10
2399.55		87168.45	239.96		8716.91	10
1663.75		71689.35	229.53		8204.75	12
2613.60		92508.90	313.63		9988.92	12
564.15		564.15	56.42		56.42	10
264.00	10.00	13999.39	28.40	1.00	1410.00	10
21421.49	37.01	928616.60	2312.10	9.93	90234.91	

012-2

CONCESSIONS REPORT

December 1946

CONTRACT NUMBER	CONCESSIONAIRE	LOCATION	ORIGINAL CONTRACT DATE	ACTUAL OPENING DATE	EXPIRATION DATE	BUILDING VALUATION	GROSS R		
							DECEMBER 1946	AD	
COMMERCIAL									
80A	B & B Dry Cleaners	Plot No. 3	7-17-44	10-25-45	12-31-46	*** 750.00	7104.22		
104A	J. Cipolloni Shop	S. Central Cafeteria	9-6-44	12-1-44	11-30-47	750.00	517.80		
113A	Spears Vac Clean & Sales	Plot No. 4	1-19-45	1-19-45	1-19-47	860.00	663.70		
118-A	O'Neal Dry Cleaning	O. Ridge Turnpike	2-9-45	7-11-45	2-9-47	8095.00	4481.25		
191	X.Y.Z. Company	Plots 13 & 14	10-29-45	12-7-45	11-30-47		* - 0 -		
226	Oak Radio Service	Plots 1 & 2	7-1-46	7-1-46	6-30-47	1330.00	669.60		
233	McConnell Fruit Company	Plots No. 7	11-1-46	11-1-46	1-31-47	750.00	2524.92		
							15961.49		

DEPARTMENT STORES & READY-TO-WEAR

118	Samuel's Mens Store	Jackson Square	12-1-43	3-22-44	12-31-47	22690.00	37260.31	
24C	Taylor's	Broadway	9-1-46	9-5-46	8-31-47	212090.00	* - 0 -	1:
25	McCrery's Stores, Corp.	Broadway	9-7-43	4-1-44	6 Mo. Duration	69800.00	* - 0 -	
49	Knight's Inc.	Grove Center	11-7-44	1-16-45	12-31-46	11760.00	22130.48	
56A	The Athletic House, Inc.	Middletown Section	2-19-45	2-19-45	2-19-47	7260.00	6818.63	
93A	The Jewell Lee Shop	Broadway	3-15-44	11-2-44	12-31-46	27900.00	25747.90	
95A	The Hegin Shoes Store	Jackson Square	9-26-44	1-12-44	12-31-46	7400.00	5109.66	
106ZA	Wender's Mens Shop	Grove Center	1-15-45	2-24-45	1-15-47		15152.02	
175	Bonita's	Grove Center	10-15-45	11-23-45	10-14-47	4800.00	4875.99	Cr.
187	National Stores, Corp.	Grove Center	12-1-45	11-16-45	2-28-47	24000.00	29469.09	
222	Bob Guess Variety Store	Rebtsv. Rd. W. of Seneca	6-1-46	6-7-46	5-31-47		6539.36	
222	Bob Guess Variety Store	Plots 27 & 28 Farm Area	11-1-46	11-1-46	5-31-47		3396.31	
							156480.24	1

FARMERS' PRODUCE MARKET

36B	H & H Produce Market #1	O. Ridge Tnpke & W. Div. Rd.	4-28-44	5-29-44	6-30-47		22612.44	Cr.
45C	Watson's Food Market	Plots 3, 4 & 5	8-1-46	8-1-46	7-31-47		15586.65	Cr.
72A	General Produce Market #1	O. R. Tnpke & W. Div. Rd.	7-23-44	8-17-44	12-31-46		10472.64	
78A	H & H Produce Market #2	Middletown Section	8-16-44	8-22-44	12-31-46		19794.39	
100B	Erb-Ana Poultry Farm	Bethel Valley Road	9-12-44	5-21-45	5-21-47		2226.19	
133	Oak R. Farmer's Ret. Mkt.	Farm Market Area		6-2-45	#		- 0 -	
144	Cowherd's Market	O.R. Tnpke & W. Div. Rd.	6-29-45	6-29-45	6-29-47		7590.36	
211	Watson's Market	Plots 9 & 10, Farm Area	3-15-46	3-20-46	3-14-47		2678.14	
232	H & H Produce Market #3	Middletown Section			12-20-47		4682.52	
							85642.23	Cr.

•	Delinquent	#	Seasonal Operation
••	Not open During Current Month	#•	Duration Plus 6 Months
•••	Terminated	#••	Withdraw Before Operations
###	Transferred to Termination	#•••	No Sales Made During Current Month
###	Transferred from License Agreements	#	Transferred to Miscellaneous
o	Sworn Statement Not Received	•	

NOTE: THIS REPORT IS FOR STATISTICAL PURPOSES AND DOES NOT PURPORT TO REPRESENT CONTROL OF REVENUE.

CONCESSIONS REPORT

December 1946

NO	GROSS RECEIPTS			RENTAL PAYMENTS			PERCENTAGE OF RENTALS
	DECEMBER 1946	ADJUSTMENTS	TOTAL TO DATE	DECEMBER 1946	ADJUSTMENTS	TOTAL TO DATE	
	7104.22		124795.11	710.42		7771.01	6
	517.80		9997.00	51.78	.01	997.76	10
	663.70	527.70	21663.95	66.37	52.77	1968.31	10
	4481.25		116452.85	400.00		7069.37	5 - \$400 Min.
	* - 0 -		30435.29	- 0 -		2153.57	7
	889.60		5219.48	66.96		521.95	10
	2524.92		5946.00	126.25		297.30	5 - \$60.00 Min.
	<u>15981.49</u>	<u>527.70</u>	<u>314509.48</u>	<u>1421.78</u>	<u>52.78</u>	<u>20779.27</u>	
	37250.31		818777.11	3725.03	.05	81877.75	10
	* - 0 -	119801.60	408811.08	- 0 -	7188.10	24528.67	6
	* - 0 -		1811566.79	- 0 -		85812.28	4 & 5
	22130.48	94.60	878913.05	2213.05	9.46	76541.60	10
	6818.63		186972.90	545.49		12842.50	8
	25747.90	197.50	563295.80	2574.79	Cr. 3.35	48927.96	10
	5109.55		150495.17	510.86		13467.63	8 & 10
	15152.02		243346.89	1515.20		21755.36	10
	4875.99	Cr. 2.01	33794.24	487.60	Cr. .20	3379.42	10
	29459.09		237511.29	1768.07		20475.78	10
	6539.96		33962.45	393.40		2038.97	6, 7 & 8
	3396.31		5049.56	203.78		362.97	6
	<u>156480.24</u>	<u>120091.69</u>	<u>5371496.33</u>	<u>13935.27</u>	<u>7194.06</u>	<u>391810.59</u>	
	22812.44	Cr. 1.74	515106.05	564.81	Cr. .04	12877.17	2 1/2
	15686.65	Cr. 10.02	69078.94	545.53	41.15	2677.58	3 1/2
	10472.54		212095.35	861.81		5302.37	2 1/2 - \$120 Min
	19794.39		599030.67	494.38		14970.27	2 1/2
	2225.19	2.06	17394.29	42.38	.09	344.57	1 & 2
	- 0 -		79807.07	- 0 -		2394.24	3
	7590.36		83123.07	316.61	.01	3396.90	4
	2878.14		46304.01	100.73	Cr. 83.22	1743.85	3 1/2 - \$60.00 Min
	4682.52		4682.52	117.06		117.06	
	<u>85842.23</u>	<u>Cr. 9.70</u>	<u>1628621.97</u>	<u>2442.79</u>	<u>Cr. 42.01</u>	<u>43723.11</u>	

VENUE.

CONCESSIONS REPORT

December 1946

CONTRACT NUMBER	CONCESSIONAIRE	LOCATION	ORIGINAL CONTRACT DATE	ACTUAL OPENING DATE	EXPIRATION DATE	BUILDING VALUATION	G R C	
							DECEMBER 1946	1946
GROCERY STORES & SUPER MARKETS								
13B	C & S Market	New York & Utah Aves.	1-1-44	2-21-44	12-31-46	37860.00	54686.28	
14A	City Market	Tennessee & Tacoma	1-1-44	2-25-44	12-31-46	37860.00	31302.15	
21B	Community Stores #1	Jackson Square	7-1-43	8-4-43	6-30-47	57700.00	81948.09	
26D	Community Store #8	Outer Dr. & Ogden Lane	10-20-46	10-20-46	1-20-47		23971.22	
37	The A & P Tea Company	Broadway	5-13-44	8-24-44	6-30-47	57720.00	91574.71	
38	Gamble Valley Super Market	Gamble Valley Tr. Camp	3-3-44	9-11-44	1-31-47 ***	31000.00	22440.19	
40B	Community Store #2	Alabama & Arkansas	3-25-44	6-16-44	6-30-47	39400.00	26581.39	
55A	Midtown Enterprises (Sup. Mkt)	Middletown Section	5-31-44	8-1-44	6-30-47	56880.00	68300.99	
61A	J. H. Jones Food Market	White Hutment Section	7-1-44	7-1-44	6-30-47	20930.00	10417.01	
64A	The Tulip Town Company	Grove Center	6-1-44	10-1-44	6-30-47	129080.00	94046.58	
147	E.A.T. Stores, Inc.	Jefferson Circle	9-15-46	10-13-46	8-31-47		40763.26	
165	Hilltop Market	W. Outer Dr. & Ill. Ave.	10-16-46	10-16-46	10-14-47		20933.36	
185	S & B Food Market	Rbtav. Rd. W of Seneca	11-1-46	12-5-46	10-31-47		25401.77	
							574366.00	
JACKSON SQUARE ARCADE								
8B	J. E. Lutz & Company, Inc.	Office 10	10-16-43	10-19-43	11-30-47	1130.00	6425.00	
9B	M. F. Flenniken & Company	Office 9	10-16-43	10-23-43	11-30-47	670.00	1877.90	
10B	Hurlay, Wright & Powell, Inc.	Office 8	10-16-43	10-16-43	11-30-47	670.00	5562.53	
197	Oak Ridge Baking Company	Office 11	4-1-46	10-1-46	3-31-47		- 0 -	
228	Royal Jewelers of O. R. Tenn.	Office 12 & 13	10-1-46		9-30-47		45089.94	
230	The Bootery	Office 14 & 15	11-1-46	11-29-46	10-31-47		7540.09	
231	Office Supply & Stationery Co.	Office 16	11-1-46	12-2-46	10-14-47		1415.61	
L-300	Church of Nazarene	Office 1	2-1-46	2-1-46	2-1-46 ***		*** - 0 -	
L-355	National Lutheran Church	Office 2	4-16-45	4-16-45	##		- 0 -	
L-359	Baptist Church	Office 3	4-16-45	4-16-45	##		- 0 -	
G-360	United Church	Office 4	4-16-45	4-16-45	##		- 0 -	
L-361	Lutheran M. Synod	Office 5	4-20-45	4-20-45	##		- 0 -	
L-362	Methodist Church	Office 6	4-15-45	4-15-46	##		- 0 -	
L-363	Presbyterian Church	Office 7	5-15-45	5-15-45	##		- 0 -	
							67911.07	
CONTRACTORS								
422A	Cox Service Company	Warehouse C-4	12-12-46	1-12-46	12-31-46	1960.00	423.89	
922A	Hopkins & Hicks	Emory Valley Road	1-23-45	1-23-45	5-31-47		- 0 -	
108A	Hagaman Electric Company	West Division Road	10-18-44	11-18-44	2-28-47		- 0 -	
126A	John A. Johnson Const. Co.	West Division Road	5-7-45	5-7-45	##		- 0 -	
167	C. W. Underwood Window Cl. Co.	East Division Road	9-9-45	9-15-45	9-7-47		- 0 -	
168	Orkin Exterminating Company	East Division Road	9-10-45	9-10-45	2-28-47		- 0 -	
171	Roach Plumbing & Heating Co.	Lucknow Circle	9-17-45	9-17-45	9-16-47		- 0 -	
214	Fletcher Moore Contractor	Raccoon Ave. & Marmet Rd.	3-1-46	3-1-46	2-28-47		- 0 -	
217	Engineering & Equipment	Div. 5, Seabore Road	4-1-46	4-16-46	3-31-47		- 0 -	
221	H. H. Galyean	Box 5052 Fountain City	5-1-46	5-1-46	4-30-47		- 0 -	
L-335	Nash & Ruckel Electric Co.	East Division Road	9-1-46	9-1-46	12-31-46 ##		- 0 -	
L-409A	East Tennessee York Company	Coal Yard Road	5-15-46	5-15-46	##		- 0 -	
							423.89	

* Delinquent
 ** Not Open During Current Month
 *** Terminated
 ## Revoicable at Will
 ### Transferred to Terminations
 # Seasonal Operation
 ## Duration Plus 6 Months
 ### Withdrew Before Operation
 / No Sales Made During Current Month

NOTE: THIS REPORT IS FOR STATISTICAL PURPOSES AND DOES NOT PURPORT TO REPRESENT CONTROL OF REVENUE

CONCESSIONS REPORT

December 1946

BUILDING VALUATION	GROSS RECEIPTS			RENTAL PAYMENTS			PERCENT OF RENTA
	DECEMBER 1946	ADJUSTMENTS	TOTAL TO DATE	DECEMBER 1946	ADJUSTMENTS	TOTAL TO DATE	
17860.00	34686.28		1219770.83	840.59		25608.88	2 & 3
17860.00	31302.15		865513.20	737.06	Cr. .01	17802.46	2
17700.00	81948.09	1126.52	3156334.15	1694.00	22.88	63834.57	2 & 3
	23971.22		56719.43	668.59		1557.11	2-3/4
17720.00	91574.71	.01	1846085.49	1831.49		36921.71	2
11000.00	22440.19		893294.10	448.80		17865.88	2
19400.00	28681.39	Cr. 33.78	894023.38	621.06		19404.91	2 & 3
18860.00	68300.99		2489589.49	1756.01		56027.97	2, 2.7 &
10930.00	10417.01		421715.07	250.07	20.00	8582.38	2
19080.00	94046.58	514.38	2592016.18	2502.29	12.86	69943.52	3 & 2-1/2
	40763.26		563836.61	968.37		11845.14	2
	20933.36		272776.35	710.04	77.69	7843.78	2-3/4
	25401.77		292078.37	812.35	153.31	7633.34	2-1/2
	574366.00	1606.13	15663550.65	13820.72	286.73	344871.56	
1130.00	6425.00		210795.02	192.75		6335.69	3-1/2 M
670.00	1877.90	Cr. 3.90	67160.49	56.34	Cr. .12	2115.60	3-1/2 55 M
670.00	5662.53	Cr. 38.25	100490.34	165.52	Cr. 1.11	3013.38	3-1/2 55 M
	- 0 -		- 0 -	- 0 -		- 0 -	
	45089.94		65110.57	4508.99		6511.00	10
	7540.09		8179.86	763.01		826.99	
	1415.81		1415.81	169.87		169.87	
***	- 0 -		- 0 -	- 0 -		117.00	\$13.
	- 0 -		- 0 -	10.00		206.00	\$10.
	- 0 -		- 0 -	14.00		294.00	\$14.
	- 0 -		- 0 -	14.00		287.00	\$14.
	- 0 -		- 0 -	13.00		264.76	\$13.
	- 0 -		- 0 -	12.00		246.00	\$12.
	- 0 -		- 0 -	12.00		234.00	\$12.
	67911.07	Cr. 42.15	453161.99	5931.48	Cr. 1.23	20620.26	
1960.00	423.89		57129.87	38.63		3186.06	6
	- 0 -		22281.41	52.92		967.81	\$50 per
	- 0 -		35899.99	125.00		2194.49	\$ 125 per
	- 0 -		20089.45	30.00		633.78	\$ 30 per
	- 0 -		7987.62	68.17		1134.61	\$ 60 per
	- 0 -		3408.91	30.00		504.53	\$ 30 per
	- 0 -		5687.83	67.58		723.38	\$ 50 per
	- 0 -		- 0 -	- 0 -		540.00	\$ 60 per
	- 0 -		- 0 -	150.00		1425.00	\$ 150 per
	- 0 -		- 0 -	100.00		800.00	\$ 100 per
	- 0 -		- 0 -	30.00		120.00	\$ 30 per
	- 0 -		1104.59	100.00		2288.20	\$ 100 per
	423.89		153359.37	792.30		14617.75	

P. 4 of 8

ROANE-ANDERSON COMPANY
CLINTON ENGINEER WORKS
OAK RIDGE, TENNESSEE

CONCESSIONS REPORT

December 1946

CONCESSIONAIRE	LOCATION	ORIGINAL CONTRACT DATE	ACTUAL OPENING DATE	EXPIRATION DATE	Building VALUATION	GROSS RECEIPTS	
						DECEMBER 1946	ADJUSTMENT
<u>MISCELLANEOUS</u>							
Evelyn's Flower Shop	Broadway	12-4-43	2-15-44	12-31-47	14400.00	4249.68	.00
Henebry's	Broadway	10-3-43	7-5-44	12-31-47	18050.00	29519.97	
Tennessee Optical Company	Broadway	6-1-46	6-1-46	5-31-47	4450.00	1689.88	70.40
Middletown Enterprises (Theater)	Middletown Section	5-13-44	6-1-44	6-30-47	92070.00	3743.93	
Oak Radio Service	Outer Drive & Ogden Lane	1-4-46	2-1-46	12-31-46	5130.00	877.50	
Portrait Studio	Hostess House Adams Lane	1-29-44	10-2-44	12-31-46	1490.00	4877.07	
Veterinary Hospital	Emory Valley Road	9-25-44	9-25-44	12-31-46	4970.00	1210.50	
Dolores Adams (Gift Shop)	Jackson Square	7-12-44	11-30-44	4-30-47	7400.00	6314.95	1.20
Joe Parrott Advertising	Area Buses	5-26-44	12-4-44	12-31-46		285.00	
Model Cleaners	Farm Market Area	1-3-46	1-3-46	3-4-47	1330.00	1642.98	
R & H Valet Shop	Jefferson Circle	5-14-46	5-14-46	5-14-47	8270.00	6441.00	
Furniture Exchange	Middletown Section	5-15-46	8-1-46	7-14-47		2473.95	Cr. 2.00
The Uniform Shop	S. Side Central Cafeteria	7-1-46	9-3-46	12-31-46		730.66	
Clinch Radio Shop	Farm Market Area	7-20-46	9-6-46	4-17-47	1330.00	866.96	
Middletown Hdwe. & Appliance Co.	Middletown Section	7-15-46	8-13-46	7-15-46		17842.41	
F & M. Ice Company	Raccoon Road	6-25-46	6-25-46	6-30-47		5369.87	
Allard's Upholstering Shop	G-4 Hhse. Gamble Valley	8-1-46	8-1-46	7-31-47		5049.76	
Modern Housekeeping Shop	Farm Market Area	10-1-46	9-10-46	9-30-47		1261.38	
Artistic Signs	West & East Division Roads	9-21-46	9-21-46	9-30-47		138.15	Cr. 40.00
Alexander Hotels Inc. (Guest House)	Broadway & Kentucky	1-16-46	1-16-46	1-15-47		8690.49	
Happy Valley Enterprises	K-25, West Oak Ridge	1-15-46	1-15-46	6-30-47		6998.71	
The Music Box	Broadway	3-1-46	4-25-46	2-28-47		6895.70	20.77
Area Laundry & Dry Cleaning Co.	Tyler & Tyrone Roads	10-1-46	9-30-46	9-30-47		31477.28	
Automatic Laundry Service Co.	Area Dormitories	3-4-46	3-4-46	3-3-47		622.30	
Crowe Woodworking shop	Raccoon Road	5-15-46	6-1-46	5-14-47		1627.50	Cr. .30
Stork Diaper Service	Beaver Way & Badger Ave.	8-12-46	9-9-46	8-11-47		1666.45	Cr. 5.00
Rutherford Hotel	Reyce Circle	9-16-46	9-16-46	9-15-47		4499.76	127.50
Frederick T. Hais (Jewelry Rep.)	Broadway & Georgia Avenues	12-16-46	12-16-46	12-15-47		- 0 -	
Frank Shelton (Hay Harvesting)	Bethel Valley	6-1-46	Seasonal	12-31-46		- 0 -	
Newton Walker (Hay Harvesting)	Bethel Valley	6-1-46	Seasonal	12-31-46		- 0 -	
						156863.55	172.74
<u>SHOE REPAIR</u>							
Schubert Shoe Repair	Jackson Square	10-1-43	10-30-43	6-30-47		2480.85	Cr. .08
Outer Drive Shoe Repair Shop	Outer Dr. & Ogden Lane	5-4-44	6-14-44	10-6-46		- 0 -	Cr. 10100.00
Burton's Shoe Renewery	Grove Center	8-8-44	9-9-44	12-31-46		6776.02	Cr. .46
Jefferson Shoe Shop	Jefferson Circle	11-16-45	11-16-46	11-14-47		924.80	
						10180.47	Cr. 10100.53

Delinquent	Seasonal Operations
Not Open During Current Month	Duration Plus 6 Months
Terminated	Withdrew Before Operation
Revocable at Will	No Sales Made During Current Month
Transferred to Terminations	

THIS REPORT IS FOR STATISTICAL PURPOSES AND DOES NOT PURPORT TO REPRESENT CONTROL OF REVENUE

ROANE-ANDERSON COMPANY
 CLINTON ENGINEER WORKS
 OAK RIDGE, TENNESSEE

CONCESSIONS REPORT

December 1946

Building LOCATION	GROSS RECEIPTS			RENTAL PAYMENTS		TOTAL TO DATE	PERCENTAGE OF RENTALS
	DECEMBER 1946	ADJUSTMENTS	TOTAL TO DATE	DECEMBER 1946	ADJUSTMENTS		
1400.00	4249.68	.07	137545.38	894.96	.01	16290.36	14
1060.00	29519.97		538453.65	2656.74		39157.15	9
1450.00	1689.88	70.46	14366.96	101.39	4.23	861.96	6
1070.00	3743.93		135035.34	487.99		14482.96	12 1/2
1130.00	877.50		16905.56	150.00		1804.50	10-3/4 150 Min.
1490.00	4877.07		59196.36	632.09		8443.75	5-3/4 50 Min.
1970.00	1210.50		32321.10	60.53		1644.21	12
1400.00	6314.95	1.25	96244.59	757.79	Cr. .10	8905.88	20
	285.00		16633.96	57.00	Cr. .10	3326.79	5
1330.00	1542.98		39473.18	98.58		2368.39	10
1270.00	6441.80		94476.55	860.86		9523.58	5
	2473.45	Cr. 2.00	47891.68	130.20	Cr. .09	2432.77	5
	730.66		12136.86	58.36	8.93	1015.87	10-3/4 60 Min
1330.00	866.96		13533.72	86.28		1358.08	5, 6, & 7
	17848.41		226650.04	1137.96		13747.49	5-3/4 300 Min
	5369.87		243982.33	268.40		12199.03	6
	5049.75		59193.31	311.49		3594.10	5-3/4 60 Min
	1261.38		14439.15	77.09	1.48	973.98	7-3/4 25 Min
	138.16	Cr. 40.00	1915.23	25.00		390.48	33 1/3
	8690.49		112012.45	869.06		11201.26	2-3/4 & 3-3/4
	6998.71		149438.28	192.46		4109.58	10
	6895.70	20.77	33852.69	697.41	Cr. 1.40	3393.12	10
	31477.26		93902.60	2515.18		7512.21	8
	522.30		4787.10	52.23		478.71	10-3/4 150 Min
	1627.50	Cr. .30	11304.28	162.75	Cr. 15.40	1235.88	8
	1666.45	Cr. 6.01	4412.34	93.99	Cr. .90	264.78	0
	4499.78	127.50	15102.77	449.98	12.75	1810.28	10-3/4 300 Min
	- 0 -		- 0 -	- 0 -		- 0 -	10-3/4 100 Min
	- 0 -		- 0 -	- 0 -		- 0 -	0
	- 0 -		- 0 -	- 0 -		- 0 -	0
	156863.56	172.74	2227207.43	15888.76	9.41	172547.60	
	2480.85	Cr. .08	72478.98	296.17	Cr. 2.55	9654.06	12
	- 0 -	Cr. 10100.00	- 0 -	- 0 -	Cr. 1211.87	- 0 -	12
	6775.02	Cr. .46	243429.00	711.61	Cr. .04	23877.00	12 & 10
	924.80		13200.10	110.95		1584.01	12
	10180.47	Cr. 10100.53	329108.08	1118.73	Cr. 1214.46	35116.06	

P.508

ROANE-ANDERSON COMPANY
CLINTON ENGINEER WORKS
OAK RIDGE, TENNESSEE

CONCESSION REPORT

DECEMBER 1946

CONTRACT NO.	CONCESSIONAIRE	LOCATION	ORIGINAL CONTRACT DATE	ACTUAL OPENING DATE	EXPIRATION DATE	BUILDING VALUATION	GROSS	
							DECEMBER 1946	A
<u>DRUG STORES</u>								
3B	Pine Valley Pharmacy	New York & Utah Avenues	1-1-44	1-8-44	12-31-47	17380.00	11504.99	
22C	Williams Drug Store	Jackson Square	7-5-43	8-1-43	6-30-47	16700.00	34727.08	
29B-	Outer Drive Drug Store	Outer Drive & Ogden Lane	3-4-44	6-13-44	12-31-47	14140.00	4937.11	
30A	Elm Grove Drug Store	Tennessee & Tacoma	2-4-44	5-27-44	3-31-47	17680.00	11362.91	Cr.
34B	Service Drug Store	Broadway	2-5-44	6-15-44	3-31-47	23280.00	23579.79	
39A	East Village Drug Store	Alabama & Arkansas	2-26-44	7-10-44	6-30-47	14800.00	6536.06	
66A	Hoskins Drug Store	Jefferson Circle	4-17-44	8-23-44	3-31-47	29680.00	42978.10	
88A	Thrifty Drugs	Grove Center	11-3-44	12-16-44	12-31-47	21470.00	24415.84	Cr.
192	Hilltop Drug Store	Ill. Avenue & W. Outer Dr.	1-15-46	1-15-46	1-14-47		4546.77	
							164588.64	
<u>RESTAURANTS & LUNCH ROOMS</u>								
33C	Townsite Fountain	Jackson Square	3-28-44	7-19-44	6-30-47	15090.00	- 0 -	
41A	T & C Cafe	Jackson Square	4-19-44	5-29-44	6-30-47	31730.00	19821.70	
77ZA	Jefferson Snack Bar	Jefferson Bus Station	2-2-45	2-2-45	2-2-47		9227.92	
79A	Townsite Fountain #3	Middletown on O. R. Turnp.	8-14-44	4-3-45	12-31-46	8000.00	3973.64	
90A	Graham's	Grove Center	2-15-46	3-9-46	12-2-46	18420.00	- 0 -	
135A	Drive Inn	O. R. Tnpke & Robtsw. Rd.	7-1-45	7-1-45	12-31-46		1960.91	
139 A	R. O. Mitchell Ice Cream & Nov.	Middletown Section	7-1-45	7-3-45	12-16-46		1457.20	
139B	Harry C. Sheffey	Middletown Section	12-17-46	12-17-46	6-30-47		1085.95	
142A	Taft Moody Ice Cream	Jackson Square	7-1-45	7-1-45	6-30-47		16142.40	
150	Park Service Company	P. O. Box 158	7-2-45	7-2-45	7-1-47		- 0 -	
153	Central Terminal Bus Bar	Central Bus Terminal	8-15-45	11-4-45	9-30-47		18527.47	Cr.
164	Canteen Food Service	Central Avenue	8-20-45	8-29-45	8-31-47		- 0 -	
164	Canteen Food Service	Jefferson Avenue	8-20-45	8-27-45	8-31-47		- 0 -	
183	Leatherman & Alley Restaurant	Washington La. C. R. Tnpke	10-1-45	10-19-45	10-18-47		13433.03	
189	The Waffle Shop	Grove Bus Terminal	11-1-45	11-15-45	10-31-47		4178.28	
194	Commercial "elicatessen	Grove Center	1-1-46	2-1-46	12-31-47		2409.37	
197	Oak Ridge, Baking Company	Adams Lane	4-1-46	4-1-46	3-31-47		9813.06	
204A	Bus Drivers Lunch Bar	Central Bus Terminal	1-21-46	1-21-46	5-9-47		1460.00	
225	Peacock Lodge Drive-In	Oak Ridge Turnpike	5-1-46	5-1-46	4-30-47		8786.95	
223	Mayflower Grill, Inc.	Tenn. Ave. & Towns Road	11-15-46	12-29-46	11-14-47 **		1455.90	
227	Colored Hutment Restaurant	Colored Hutment Section	7-1-46	7-1-46	12-31-46		- 0 -	
227A	Colored Hutment Restaurant	Colored Hutment Section	1-1-47	1-1-47	1-31-47		- 0 -	
							113733.78	

- Delinquent
- Not Open During Current Month
- Terminated
- ## Revocable at Will
- ### Transferred to Terminations
- # Seasonal Operation
- ## Duration Plus 6 Months
- ### Withdrew Before Operation
- ⚡ No Sales Made During Current Month

NOTE: THIS REPORT IS FOR STATISTICAL PURPOSES AND DOES NOT PURPORT TO REPRESENT CONTROL OF REVENUE

ROANE-ANDERSON COMPANY
CLINTON ENGINEER WORKS
OAK RIDGE, TENNESSEE

CONCESSION REPORT

DECEMBER 1946

DESCRIPTION	GROSS RECEIPTS			RENTAL PAYMENTS			TOTAL TO DATE	PERCENTAGE OF RENTALS
	DECEMBER 1946	ADJUSTMENTS	TOTAL TO DATE	DECEMBER 1946	ADJUSTMENTS	TOTAL TO DATE		
.00	11504.99		398109.62	950.60		29850.96	8 to 10M 10 above	
.00	34727.08		1380882.66	3272.71		114997.86	4 & 12	
.00	4937.11	1.00	174579.19	394.97	.09	13965.66	8 to 10M 10 Above	
.00	11362.91	Cr. 109.05	286824.43	936.29	Cr. .72	21251.42	8 to 10M 10 Above	
.00	23579.79	.12	549620.00	1886.39	.50	51206.52	8 & 10	
.00	6536.06		221646.91	502.88		16741.86	8 & 10	
.00	42978.10	451.47	1341709.20	3476.25	Cr. 11.98	105776.10	8 to 50M 10 Above	
.00	24415.84	Cr. 1.00	730438.14	1953.27	Cr. .08	57135.00	8 & 10	
	4546.77		49464.03	454.68	15.90	4962.32	10	
	164588.64	342.64	5133274.18	13827.94	3.71	416887.66		
.00	* - 0 -		640396.30	- 0 -		27817.83	8 & 10	
.00	19821.70	45.19	748955.92	1589.36	131.32	53237.06	8	
	9227.92	12.07	193267.61	757.26	2.89	13712.20	8	
.00	3973.64		154778.96	317.89	Cr. 8.61	12382.29	8	
.00	- 0 -		52716.81	- 0 -	23.08	5294.77	10	
	1960.91		61227.80	181.87		5048.22	8	
	1457.20		43023.50	117.87		3455.66	8	
	1085.95		1085.95	88.17		88.17	8	
	16142.40		613242.26	329.32		14373.73	2 & 3	
*	- 0 -		104885.58	- 0 -		8390.83	8	
	18527.47	Cr. 1.90	245162.29	1852.74	43.93	24560.34	10	
*	- 0 -		721519.76	- 0 -		8959.83	1	
*	- 0 -		496076.11	- 0 -		5840.22	1	
	13433.03		315031.63	1028.09		22256.98	7	
	4178.28	4469.14	64121.90	208.91	223.46	3242.12	5 - \$50 Min	
	2409.37		24732.64	152.91		1715.62	5 - \$50 Min.	
	9813.06		38074.77	490.06		1298.78	5	
	1460.00	2.04	16310.90	145.21		206.46	10	
	8786.95		101461.58	927.98		9481.45	10	
	1455.90		1455.90	145.59		145.59	10	
	- 0 -		- 0 -	50.00		300.00	\$50 per Mo.	
	- 0 -		- 0 -	- 0 -		- 0 -	\$50 per Mo.	
	113733.78	4526.54	4637528.15	8382.23	416.07	223668.14		

P. 6 of 8

ROANE-ANDERSON COMPANY
CLINTON ENGINEER WORKS
OAK RIDGE, TENNESSEE

CONCESSION REPORT

DECEMBER 1946

CONTRACT NO.	CONCESSIONAIRE	LOCATION	ORIGINAL CONTRACT DATE	ACTUAL OPENING DATE	EXPIRATION DATE	BUILDING VALUATION	GROSS DEC-EMBER 1946
<u>GALESBURG HALL (102 South Jefferson Circle)</u>							
220-G1	J. E. Brown, Intl. Cer. Schools	Room 107	4-1-46	4-1-46			
G2	Olen W. Henderson, Attorney	Room 102	5-15-46	5-15-46			
G4	W.O. Lowe & Frank Wilson, Attys.	Room 125 & 127	5-13-46	5-15-46			
G5	Frank W. Dedman, Mutual Life	Room 217 & 219	5-16-46	5-15-46			
G5A	Walter S. Fleener " " "	" " "	5-15-46	5-15-46			
G6							
G7	W.R. Middlethom, N.Y. Life	Room 210	5-15-46	5-15-46			
G8A	Howard Heldreth, Protective Life	Rooms 117 & 119	5-15-46	5-15-46			
G10A	Norval Hopwood, Prudential	Room 106	8-1-46	8-1-46			
G11	P.A. Taliaferro, Aetna Life Ins.	Room 209	5-15-46	5-15-46			
G12							
G13							
G14	G.C. Edwards, Mgr. Home Beneficial Ins. Company	Room 121	5-15-46	5-15-46			
G15							
G15B	United Gas, Coke & Chemical workers of America, CIO	Recreation Room					
G16							
G17	Glenwood Baptist Church	Room 203	10-1-46	10-1-46			
G18	O.R. Lodge U.D.F. & A.M. (Masons)	Rooms 231 to 250	10-1-46	10-1-46			
G19	Mrs. Melba Whitson	Room 105	7-15-46	7-15-46			
G20	F.K. Shoek	Room 109					
G21	J.B. Harris, Pastor Triality Methodist Church	Room 104	6-1-46	6-1-46			
G22	Walter E. Fischer	Rooms 118, 120 & 122	6-10-46	6-10-46***			
G23	F. H. Hopkins	Room 123	12-1-46	12-1-46***			
G24	Ruby Kate Holland	Room 124	1-1-47	1-1-47			
G25	J.P. Deal, Jefferson Std. Life Ins. Company	Room E 3					
G26	Metropolitan Life Ins. Co. T.C. Simpson, Agt.	Room 128					
G30	J.S. Elliott	Room 203	7-1-46	7-1-46			

DENTISTS - FLAT RENTAL

205-D1	Burgess, W. B.	Tennysen Rd. & OR Tnpke.	2-1-46	2-1-46		
D2						
D3	Bowyer, Frank P.	Tennysen Rd. & OR Tnpke.	2-1-46	2-1-46		
D4	Underwood, Harry M.	Tennysen Rd. & OR Tnpke.	2-1-46	2-1-46		
D5	Grigsby, Leroy	Tennysen Rd. & OR Tnpke.	2-1-46	2-1-46		
D6	Yearwood, Jack	Tennysen Rd. & OR Tnpke.	2-1-46	2-1-46		
D7	Llewellyn, Clarence D.	Tennysen Rd. & OR Tnpke.	2-1-46	2-1-46		
D8	Squires, William A.	Tennysen Rd. & OR Tnpke.	2-1-46	2-1-46		
D9	Mills, Shirley M.	Tennysen Rd. & OR Tnpke.	2-1-46	2-1-46		

* Delinquent
 ** Not open during current month
 *** Terminated
 # Seasonal Operation
 ## Duration Plus 6 Months
 ### Withdrew before Operations

NOTE: THIS REPORT IS FOR STATISTICAL PURPOSES AND DOES NOT PURPORT TO REPRESENT CONTROL OF REVENUE.

C 13-1

R T

SS RECEIPTS		RENTAL PAYMENTS			PERCENTAGE
ADJUST- MENTS	TOTAL TO DATE	DEC- EMBER 1946	ADJUST- MENTS	TOTAL TO DATE	OF RENTALS
		25.00		208.90	26.30
		46.00		337.50	45.00
		67.92		497.94	65.00
		-0-	Cr. 200.00	-0-	25.00
		25.00		25.00	25.00
		-0-		-0-	
		25.00		187.50	25.00
		25.00		62.50	50.00
		25.00		125.00	25.00
		25.00		187.60	25.00
		-0-		-0-	
		-0-		-0-	
		25.00		187.50	25.00
		205.00		680.00	135.00
		-0-		-0-	
		20.00		60.00	20.00 per Month
		145.00		436.00	145.00 per Month
		25.00		137.50	25.00
		25.00	12.50	37.50	
		25.00		150.00	20.00
		-0-	Cr. 425.00	-0-	75.00
		-0-		-0-	25.00
		-0-		-0-	25.00
		-6-		-0-	25.00
		-0-		-0-	40.00
		46.00		220.00	40.00
<hr/>		777.92	Cr. 612.50	3,534.34	
<hr/>					
		80.00		840.00	
		-0-		-0-	
		200.00		2,115.00	
		184.31		1,662.27	
		55.00		592.50	
		90.00		980.39	
		75.00		750.00	
		75.00		754.00	
		105.76		710.96	

P. 7 of 8

ROANE-ANDERSON
CLINTON ENGINEER
OAK RIDGE, TEN

CONCESSION

DECEMBER 1

CONTRACT NO.	CONCESSIONAIRE	LOCATION	ORIGINAL CONTRACT DATE	ACTUAL OPENING DATE	EXPIRATION DATE
<u>DENTISTS, CONTINUED</u>					
205-D10	Beeler, Ted P.	Tennysen Road & O. R. Turnpike	4-12-46	4-12-46	
D11	William, W. F.	Tennysen Road & O. R. Turnpike	5-1-46	5-1-46	
D12					
D13	Chapman, William T. Jr.	Tennysen Road & O. R. Turnpike	8-1-46	8-1-46***	
345	Oak Ridge Health Association	Tennysen Road & O. R. Turnpike	6-1-46	6-1-46	
<u>DOCTORS - FLAT RENTAL</u>					
210-M1					
M2					
M3	Eggleston, John R.	Tennessee Ave. & Tennysen Road	3-1-46	3-1-46***	
M4	De Persio, John	Tennessee Ave. & Tennysen Road	1-1-47	1-1-47	
M5	Rossmann, Hyman M.	Tennessee Ave. & Tennysen Road	3-1-46		
M6					
M7					
M8	Pugh, A. W. Jr.	Tennessee Ave. & Tennysen Road	3-1-46	3-1-46	
M9	Williams, Cordell H.	Tennessee Ave. & Tennysen Road	3-1-46	3-1-46	
M10	Dings, Parley M.	Tennessee Ave. & Tennysen Road	3-1-46	3-1-46	
M11	Helz, Harry C.	Tennessee Ave. & Tennysen Road	3-1-46	3-1-46	
M12	Jagwell, Troy	Tennessee Ave. & Tennysen Road	3-1-46	3-1-46	
M13	Price, R. M.	Tennessee Ave. & Tennysen Road	3-1-46	3-1-46	
M14					
M15	Diamond, J. L.	Tennessee Ave. & Tennysen Road	9-10-46	9-10-46	
M16A	Whitaker, Carl A.	Tennessee Ave. & Tennysen Road			1-3-47
M17	Brzostowski, Henry A.	O. R. Turnpike & Tennysen Road	5-1-46	5-1-46	
M18	Ragan, Charles J.	O. R. Turnpike & Tennysen Road			
M19	Tromley, Robert G.	Tennessee Ave. & Tennysen Road	5-3-46	5-3-46	
M20	Gilbert, John B.	Tennessee Ave. & Tennysen Road	1-1-47	1-1-47	
M21	Dings, G. M.	Tennessee Ave. & Tennysen Road	7-1-46	7-1-46	
M22	Nance, Dana W.	Tennessee Ave. & Tennysen Road	5-17-46	5-17-46	
M23	Ruley, H. B.	Tennessee Ave. & Tennysen Road	6-1-46	6-1-46	
M24	Frell, Albert C.	Tennessee Ave. & Tennysen Road	6-1-46	6-1-46	
M25	Black, Mrs. Harriette	Tennessee Ave. & Tennysen Road	6-5-46	6-5-46	
M26	Davis, Dexter	Tennessee Ave. & Tennysen Road	6-11-46	6-11-46	
M27	Christie, Roy E.	Tennessee Ave. & Tennysen Road	6-5-46	6-5-46	
M28	Harmon, J. P.	Tennessee Ave. & Tennysen Road			**
M30	Preston, Louis F.	Tennessee Ave. & Tennysen Road			
M16A	Markentin, John	Tennessee Ave. & Tennysen Road			
235	Dr. Frank T. Rogers	Tennessee Ave. & Tennysen Road	1-1-47	1-1-47	
<u>MISCELLANEOUS - FLAT RENTAL</u>					
43B	Yellow Cab Company	Administration Road	7-1-46	7-1-46	6-30-47
83B	Area Transport Company	R-A Warehouse B-13	9-26-44	10-6-44	11-30-46
124A	Warren Advertising Co.	S. Side Oak Ridge Turnpike	5-8-45	5-25-46	5-14-47
173A	Oak Ridge Bus Tickets Sales	Central Bus Terminal	6-1-45	6-1-46	11-30-47
150A	D & B Motor Shop	Whse. C-3 Gamble Valley	6-1-46	6-1-46	5-31-47
193	Food Product Co. (Cold Storage)	Coal Yard Road	11-11-46	11-11-46	11-10-46
212	The Fisher Moving & Storage SEC	O. R. Turnpike & Scarboro	2-20-46	2-20-46	2-19-47
193A	Oak Ridge Cold Storage Plant Inc.	P. O. Box # 307			**

* Delinquent
 ** Not Open During Current Month
 *** Terminated
 # Seasonal Operation
 ## Duration Plus 6 Months
 ### Withdrew Before Operations

NOTE: THIS REPORT IS FOR STATISTICAL PURPOSES AND DOES NOT PURPORT TO REPRESENT CONTROL OF REVENUE.

OANE-ANDERSON COMPANY
LINTON ENGINEER WORKS
OAK RIDGE, TENNESSEE

CONCESSION REPORT

DECEMBER 1946

EXPIRATION DATE	BUILDING VALUATION	GROSS RECEIPTS		RENTAL PAYMENTS			PERCENTAGE OR RECEIPTS
		DECEMBER 1946	ADJUSTMENTS	DECEMBER 1946	ADJUSTMENTS	TOTAL	
			TOTAL TO DATE			TOTAL TO DATE	
6				96.53		710.45	
****				89.65		643.28	
				-0-		-0-	
				63.90		315.90	
				1,115.15		10,074.72	
				-0-		-0-	
				-0-		-0-	
****				186.59		1,674.77	
				-0-		-0-	
				100.78		765.72	
				-0-		-0-	
				-0-		-0-	
				237.71		1,806.07	
				199.44		1,232.82	
				108.53		955.91	
				115.00		1,100.00	
				165.00		1,375.50	
				112.50		1,062.50	
				-0-		-0-	
6				89.60		403.83	
1-3-47				103.62		207.24	
				109.14		827.42	
				105.60	19.00	278.35	
				115.00		795.00	
				-0-		110.00	
				110.00		660.00	
				57.72		636.30	
				131.59		850.61	
				63.78		423.12	
				179.04		1,229.40	
				115.76		757.94	
				94.09		660.21	
..				131.64		371.36	
				2,632.13		19.00	18,138.37
				450.00		2,700.00	450.00 per no.
6-30-47		-0-	-0-	150.00		2,556.78	150.00 per no.
11-30-46		-0-	25053.63	80.00		612.93	80.00 per no.
5-14-47		-0-	258.50	261.09		3,022.18	250.00 per no.
11-30-47		-0-	-0-	125.00		1,415.00	125.00 per no.
5-31-47		-0-	-0-	-0-	Cr. 4786.60	-0-	400.00 per no.
6 11-10-46		-0-	-0-	150.00		1,025.00	150.00 per no.
2-19-47		-0-	-0-	-0-		-0-	
..				1,216.09		Cr. 4,786.60	11,431.89
				-0-	25312.13		

4,000.00 per no.

(a) Flat monthly rental for concession privilege for the operation of medical radiological equipment.

123

CONCESSIONAIRE	GROSS RECEIPTS			RENT
	DEC- EMBER 1946	ADJUST- MENTS	TOTAL TO DATE	DEC- EMBER 1946

TERMINATIONS

Automotive	12	-0-	258,104.97	
Barber & Beauty Shops	7	-0-	93,416.22	
Commercial Area	9	-0-	63,473.33	
Farmers Produce Market	12	-0-	504,236.73	
Grocery Stores & Super Mkts.	5	-0-	1,724,957.65	
Miscellaneous	21	-0-	866,980.19	
Restaurants & Lunch Rooms	11	-0-	1,274,634.18	
Shoe Repair	4	10,100.00	46,302.74	
Drug Stores	1	-0-	169,709.31	
Contractors	7	-0-	108,321.70	
Miscellaneous Flat Rental	3	-0-	9,929.64	
Department Stores & Ready-to-wear	2	-0-	3,642,693.61	
Doctors Flat Rental	7	-0-	-0-	
Galesburg Hall	7	-0-	-0-	
Dentists Flat Rental	1	-0-	-0-	

109

10,100.00 8,762,659.27

SUMMARY

Automotive	22	176,167.29	144.89	4,589,386.60	8,374.48
Barber & Beauty Shops	16	21,421.49	37.01	928,616.50	2,312.10
Commercial Area	6	16,961.49	527.70	314,509.46	1,421.78
Contractors	12	423.89	-0-	153,359.37	792.30
Department Stores & Ready-to-wear	11	156,480.24	120,091.69	5,371,496.33	13,936.27
Drug Stores	9	164,588.64	342.54	5,133,274.18	13,827.94
Farmers Produce Markets	9	86,842.23	Cr. 9.70	1,626,621.97	2,442.79
Jackson Square Arcade	11	67,911.07	Cr. 42.15	453,151.89	6,931.48
Miscellaneous	30	156,863.55	172.74	2,227,207.43	13,388.76
Restaurants & Lunch Rooms	20	113,733.78	4,226.54	4,637,528.15	8,382.23
Shoe Repairs	3	10,180.47	(10,100.53)	329,108.08	1,118.73
Miscellaneous Flat Rental	6	-0-	-0-	25,312.13	1,216.09
Dentists	12	-0-	-0-	-0-	1,115.15
Hospital	25	-0-	-0-	-0-	2,632.13
Galesburg Hall	20	-0-	-0-	-0-	777.92
Terminations	107	-0-	10,100.00	8,762,659.27	-0-
Grocery Stores & Super Market	13	574,366.00	1,606.13	15,563,550.66	13,820.72

1,542,940.14 127,396.86 50,115,791.01 91,489.87

- * Delinquent
- ** Not Open During Current Month
- *** Terminated
- # Seasonal Operation
- ## Duration Plus 6 Months
- ### Withdrew Before Operations
- ✓ No Sales Made During Current Month

NOTE: THIS REPORT IS FOR STATISTICAL PURPOSES AND DOES NOT PURPORT TO REPRESENT CONTROL OF REV

RENTAL PAYMENTS			
	DEC- EMBER 1946	ADJUST- MENTS	TOTAL TO DATE
		-0-	9,314.52
104.97		-0-	9,378.55
116.22		-0-	4,676.25
13.33		-0-	17,538.36
136.73		-0-	42,700.56
157.65		-0-	44,412.80
180.19		-0-	70,674.70
134.18		-0-	5,556.20
102.74	1,211.87		13,576.74
109.31		-0-	5,560.30
121.70		-0-	21,971.57
129.64	4,786.60		107,898.60
193.61		-0-	2,568.24
-0-		-0-	1,852.72
-0-	625.00		514.36
-0-		-0-	
<hr/>			
59.27	6,623.47		358,095.06
<hr/>			
86.60	8,374.48	20.96	230,998.05
16.50	2,312.10	9.93	90,234.91
09.48	1,421.78	62.78	20,779.27
59.37	792.30	-0-	14,517.75
96.33	13,935.27	7,194.06	391,810.59
74.18	13,827.94	3.71	415,887.68
21.97	2,442.79	Cr. 42.01	43,723.11
51.89	5,931.48	Cr. 1.23	20,620.26
07.43	13,388.76	9.41	172,547.60
28.15	8,382.23	416.07	223,668.14
08.08	1,118.73	Cr. 1,214.46	35,115.06
12.13	1,216.09	Cr. 4,786.60	11,431.99
-0-	1,115.15	-0-	10,074.72
-0-	2,632.13	15.00	18,188.37
-0-	777.92	Cr. 612.50	3,534.34
59.27	-0-	6,623.47	358,095.06
550.65	13,820.72	286.73	344,871.56
<hr/>			
191.01	91,489.87	7,979.32	2,406,098.36

Month

REPRESENT CONTROL OF REVENUE.

ROANE-ANDERSON COMPANY

BY V. A. TAYLOR
ASSISTANT CHIEF ACCOUNTANT

CONTRACT NUMBER	LICENSEE	LOCATION	ORIGINAL CONTRACT DATE
<u>SPACE RENTALS</u>			
L-24A	Railway Express Agency	Gen. Whse. No. 1, Section 16, 17 & 18	4-10-44
26	Southern Bell Telephone & Telegraph	N. End Barracks Edition to Main Telephone Bldg.	5-22-44
301	" " " " " "	Southwest Corner Building 1706	11-16-45
36	American Red Cross	Oak Ridge Turnpike	1-1-45
37	Louisville & Nashville Railroad Co.	whse. 8, between whse. & whse. Roads	10-10-44
43	Western Union Telegraph Company	Building 2; East Town Center	11-1-43
33C	David C. Wilson (Area Transport Co.)	West End Warehouse B-13 (Warehouse Road)	12-1-46
295	Oak Ridge Engineers & Scientists	R-A Main Office Building 1-A	1-9-46
313	Galbreath-Moore Co.	Building 809 Raccoon Road	10-25-45
315A	Batterson Bros. Trucking Co., Inc.	Johnson Cabins Office Hutment Camp Area	2-1-46
318	Canteen Service Co.	White Hutment Camp	12-1-45
319	Hobbs Vending Machine Co.	Bldg. 98-213 N. End Coupe Const. Building	2-14-46
321	Assn. of Oak Ridge Scientists	R-A Main Office Building 1-A	3-15-46
322	Taft Moody	G.V. Trailer Town, Neighborhood Stores No. 1	3-1-46
323	Atomic City Plumbing Co.	Coal Yard Road, S. Side O.R. Tnpke	4-1-46
324	J.G. Goodin Refrigerator Service	154 Georgia Avenue	4-1-46
325	Marr & Fry Fish Bait Market	Elza Gate	4-1-46
327	The Furniture Exchange	Middletown Section	4-1-46
328	Oak Ridge BPO Elks Lodge 1684	Iroquois Avenue & Jeffery Road	1-1-46
330	Atomic Trades & Labor Council (A.F. of L.)	Gamble Valley Nursery School, Houston Ave.	6-1-46
333	Veterans of Foreign Wars	Hostess House, 152 Washington Lane	8-16-46
334	Martin Funeral Home (Ambulance Service)	Oak Ridge Hospital Parking Space	9-1-46
336	Fraternal Order of Eagles	Barracks 5 & 6; 108 & 112 Pasteur Road	9-15-46
337	First Methodist Church	E. Wing of Abilene Hall, Alabama Road	9-1-46
338	Knoxville Airport Transit Service		
339	Rev. Francis A. McRedmond (Ava Maria Bookstore)		
340	George Galbreath & Major J.T. Pronger (Horse Barn)	Oak Ridge Turnpike	11-1-46
341	E.J. & A.J. Cobb, Inc.	So. of O.P. Turnpike near Johnson	11-16-46
342	Joseph Greer, Jr. Food Broker	Warehouse B-12 Brussels Road	8-1-46
353	American Legion Post No. 139	House C-289, West of Grove Center	3-1-46
367	Girl Scouts of Oak Ridge	Bldg. F-545, Southwest of Town Reservoir	4-19-45
426	Cherokee Motor Coach Co.	K-25 West Oak Ridge	11-15-45

- * Delinquent
- ** Not Open During Current Month
- *** Terminated
- ### Revocable at Will
- #### Transferred to Jackson Square Concession Report
- # Seasonal Operation
- ## Duration Plus 6 Months
- ### Withdrew Before Operations

NOTE: THIS REPORT IS FOR STATISTICAL PURPOSES AND DOES NOT PURPORT TO REPRESENT CONTROL OF REVENUE.

NAL ACT	ACTUAL OPENING DATE	EXPIRA- TION DATE	DEC- EMBER 1946	ADJUST- MENTS	TOTAL TO DATE
44	4-10-44		97.00		3,737.91
44	5-22-44)		210.50		7,945.14
45	11-16-45)				
5	1-1-45		-0-		1.00
44	10-10-44		192.00		5,184.00
43	11-1-43		20.00		520.00
46	12-1-46				
6	1-9-46		42.92		475.17
45	10-25-45		30.00		426.00
6	2-1-46 44		25.00		250.00
45	12-1-45		100.00		1,300.00
46	2-14-46		12.50		132.08
46	3-15-46		-0-		100.00
6	3-1-46		100.00		1,000.00
6	4-1-46		50.00		450.00
6	4-1-46		30.00		270.00
6	4-1-46		30.00		270.00
6	4-1-46		100.00		900.00
6	1-1-46		100.00		1,200.00
6	6-1-46		200.00		1,400.00
46	8-16-46		176.97		631.24
6	9-1-46		50.00		200.00
46	9-15-46		115.00		402.50
6	9-1-46		37.50		137.50
			-0-		-0-
			-0-		5.00
46	11-1-46		-0-		-0-
46	11-16-46	6-30-47	6.00	3.00	9.00
6	8-1-46		50.00		130.00
6	3-1-46		25.00		550.00
45	4-19-45		-0-		1.00
45	11-15-45		32.50		438.75
			1,932.39	3.00	28,066.29

2 of 2

LEASE AGREEMENTS
DECEMBER, 1946

CONTRACT NUMBER	LICENSEE	ORIGINAL CONTRACT DATE	ACTUAL OPENING DATE	EXPIRA- TION DATE
--------------------	----------	------------------------------	---------------------------	-------------------------

TERMINATIONS

BALANCES CARRIED FORWARD FROM NOVEMBER STATEMENT

SUMMARY
IN FORCE
TERMINATIONS

EASE AGREEMENTS
DECEMBER, 1946

~~SECRET~~
2 of 2

RENTAL PAYMENTS		
DECEMBER	ADJUST-	TOTAL
1946	MENTS	TO DATE

-0-		5,123.39
-----	--	----------

MARY

FORCE	1,332.39	3.00	28,066.29
-------	----------	------	-----------

MINATIONS	-0-	-0-	5,123.39
-----------	-----	-----	----------

	1,832.99	3.00	33,189.68
--	----------	------	-----------

MCANE-ANDERSON COMPANY

BY _____
V. A. TAYLOR
ASSISTANT CHIEF ACCOUNTANT

C-13-2

C-13a EQUIPMENT RENTALS REPORT, DECEMBER 1946 (3 sheets)

ROANE-ANDERSON COMPANY
CLINTON ENGINEER WORKS
OAK RIDGE, TENNESSEE

EQUIPMENT RENTAL REPORT

DECEMBER 31, 1946

R-A NO.	LESSEE	LOCATION	EQUIPMENT RENTAL					
			MISCELLANEOUS EQUIPMENT			CODED EQUIPMENT		
			DEC. 1946	ADJUST- MENTS	CUMU- LATIVE	DEC. 1946	ADJUST- MENTS	CUMU- LATIVE
170	Acuff Motor Service	Broadway			243.99			
203-A	A. B. Bar	Administration Building						503.50
142	All-American Ice Cream Co.	Townsite Fountain						186.67
156	Allard Upholstering Shop	Whse. G-4, Gamble Valley			7.57			
63	Allen's Barber Shop	Gambel Valley			47.84			
178	American Legion Post	P. O. Box 387	9.47		90.42			
83-A	Area Transport Company	Whse. B-13						1467.50
195	Atomic City Paint Company	Baltimore Ave. & Gamble Valley			32.49			171.00
L-323	Atomic City Plumbing Co.	Coal Yard Road	10.17		89.23	122.58		1497.54
80	B. & B. Dry Cleaners	O. R. Turnpike & Ill. Ave.	2.92		23.16			
L-326	B. S. K. Repair Shop	P. O. Box 1228			28.54			
52-A	J. E. Brown	101 Norwood Lane			1.47			
152, 164	Canteen Food Service, Inc.	P. O. Box 398				205.00		5289.66
153	Central Terminal Bus Bar	Central Bus Terminal			105.97			
L-320	Chemical Workers Int. Union	O. R. Turnpike & Adams Lane			14.09			
163	Claybaugh Wrecker Service	Emory Valley Road			162.42			
227	Colored Hutment Restaurant	Colored Hut Area						315.17
194	Commercial Delicatessen	Commercial Area	22.85		217.20			
200	Community Garage	K-25 Area						7.22
SC-7	Community Service Company	P. O. Box 1187	.45	.90 Cr.	2.36			
21-B	Community Store #1	Jackson Square	14.52	87.89 Cr.	19.55			
1-A	Copeland Service Station	Arkansas Ave. & O. R. Turnpike			7.68			
42-Z	Cox Service Company	Whse. C-4	6.50		70.51	380.00		2050.64
144	Cowherd's Market	Farm Market Area			48.25			
219	Crows Woodworking Shop	269 Linnet Way	19.20		135.91	49.70		200.60
209	D. & K. Delivery Service	Farm Market Area						13.00
135	The Drive-In	O. R. Turnpike & Robertsville Rd.			89.85			
SC-2	T. L. Duke	Turnpike Service Station						100.17
147	E.A.T. Stores, Inc.	Jefferson Circle			718.35			
127	East Tennessee York Co.	Coal Yard Road			3.41			
31-A	East Village Barber Shop	Ala. & Ark. Avenues	.37		2.71			
39-A	East Village Drug Store	Ala. & Ark. Avenues			35.15			
131	Edythe's Yarn Shop	Commercial Area			.17			
L-328	Elks Club	Ill. & Jeffrey Rds.	15.70		134.72			
102-A	Emory Valley Recapping Shop	Emory Valley Road	.82	.82 Cr.	8.12			

C130-1

 Service	Farm Market Area
135	The Drive-In	O. R. Turnpike & Robertsville Rd.
SC-2	T. L. Duke	Turnpike Service Station
147	E.A.T. Stores, Inc.	Jefferson Circle
127	East Tennessee York Co.	Coal Yard Road
31-A	East Village Barber Shop	Ala. & Ark. Avenues
39-A	East Village Drug Store	Ala. & Ark. Avenues
131	Edythe's Yarn Shop	Commercial Area
L-328	Elks Club	Ill. & Jeffrey Rds.
102-A	Emory Valley Retapping Shop	Emory Valley Road
217	Engineering & Equipment Co.	Scarboro Road
143	F. M. Ice Company	Raccoon Ave. & Sable Way
212	Fisher Moving & Storage	O. R. Turnpike & Scarboro Rd.
336	Fraternal Order of Eagles	
193	Food Products Company	Coal Yard Road
129	Furniture Exchange	P. O. Box 1371
SC-6	Galbreath & Moore	P. O. Box 451
73-A	Gamble Valley Beauty Shop	Gamble Valley
38	Gamble Valley Super Market	Gamble Valley
72-A	General Produce Company	Farm Market Area
SC-17	Gibson Service Mgmt. Co.	P. O. Box 1048
L-324	Goodin Refrigeration Service	154 Georgia Avenue
90-B	Graham's Restaurant	Grove Center
SC-13	Leo W. Grant	107 Umbria Lane
222	Bob Guess Dept. Store	Robertsville Rd. & Seneca
220 G-21	Harris, J. B. Pastor Trinity M. E. Church	
220 G-2	Henderson, Olen, Atty.	Galesburg Hall
36-A	H. & H. Produce Company #1	Farm Market Area
70-B	Hilltop Barber Shop	Ill. Ave. & W. Outer Drive
174	Helaine's Department Store	Commercial Area
192	Hilltop Drug Store	Ill. Ave. & Outer Drive
190	Higgs Motor Winding & Repair Shop	Whse. G-3, Gamble Valley
165	Hilltop Market	Ill. Ave. & W. Outer Drive
95	Hogin Shoe Store	Jackson Square
92-Z	Hopkins & Hicks	Emory Valley Road
119	Sam Horne Company	Middletown
66	Hoakins Drug Store	Jefferson Circle
77-Z	Jefferson Snack Bar	Jefferson Bus Terminal
93	Jewel Lee Shop	Broadway
61-A	J. H. Jones Food Market	Family Hut Area
	P. W. Jones	Charleston Hall

C-15a

71

2

			200.00
		89.85	13.00
		718.35	100.17
		3.41	
.37		2.71	
		35.15	
		.17	
15.70		134.72	
.82	.82 Cr.	8.12	
206.01		1231.31	
6.63		79.85	54.61
2.92		34.44	1535.60
21.06		52.74	
		69.45	
			565.14
4.12		45.17	
		.50	
105.53		945.91	
40.48		97.82	
			1465.00
2.92		23.16	12,135.29
1.50		198.11	
		117.78	195.00
		97.86	1,088.62
		27.82	
2.92		22.97	
		6.00	
		2.60	
		68.45	139.34
		118.34	
		784.46	183.66
.16		11.12	69.67
		112.30	
		75.20	
		82.44	
10.20		54.00	
		91.80	
2.50		63.99	
		19.00	

ROANE-ANDERSON COMPANY
CLINTON ENGINEER WORKS
OAK RIDGE, TENNESSEE

EQUIPMENT RENTAL REPORT

DECEMBER 31, 1946

RA No.	LESSEE	LOCATION	MISCELLANEOUS EQUIPMENT			CODED EQUIPMENT		
			DEC. 1946	ADJUST- MENTS	CUMU- LATIVE	DEC. 1946	ADJUST- MENTS	CUMU- LATIVE
125	Johnson, John A. Contracting Corp.	W. Division Road	7.08		56.64			
201	Kelso Motor Tune-Up	Elm Grove Area			73.56			22.31
49	Knights, Inc.	Grove Center			3.84			
220 G-12	Kirby Vacuum Agency	Galesburg Hall			.22			
183	L. and A. Club	Washington Lane & O.R. Turnpike			581.60			
SC-3	Leatherman & Alley Co.	Fairfield Hall			9.20			
18-A	McCray Barber Shop	Tenn. Ave. & Tacoma Road			14.60			
176	Mars & Company, Firestone Dealer	Grove Center	15.10	23.15 Cr.	47.71			38.88
55	Middletown Super Market	Middletown		35.22 Cr.	28.19			
50	Middletown Enterprises Theatre	Middletown	20.00	120.00 Cr.	60.00			
141	Middletown Hdwe. & Appliance Co.	Middletown			62.94			
24-A	Millers, Inc.	Broadway			38.97			
139	R. O. Mitchell Ice Cream & Novelty	Middletown			10.00			
160	Modern Housekeeping Shop	Farm Market Area			22.94			
116	Model Laundry Co.	Farm Market Area			80.40			
214	Fletcher Moore, Gen. Contr.	Near Ice Plant	10.80		111.40	141.93		1345.87
206	The Music Box	Broadway			2.71			
187	National Stores	Grove Center			144.60			
	New York Life Insurance Co.				.49			
L-295	Oak Ridge Engineers & Scientists	P. O. Box 382			33.94			
SC-4	Oak Ridge Collection Service	P. O. Box 1228			27.89	214.52		24239.37
SC-21	Oak Ridge Housing Company					2876.03		18425.86
	Oak Ridge Rec. & Welfare Assn.		848.53		7540.23	1198.47		15302.42
SC-1	Oak Service Association	P. O. Box 2011				144.50		592.74
213	O'Connor & Crowe Mtr. Service	Farm Market Area	20.65		143.92			
118	O'Neal Cleaning Co.	Commercial Area		12.16 Cr.	24.95	6.77		545.77
26-C	Outer Drive Market	Outer Drive & Ogden Lane			906.91			
162	Pan-Am Service Center	O. R. Turnpike & G. V. Rd.			154.65			
150	Park Service Company	P. O. Box 156	4.15		44.17			3.17
215	Peacock Lodge Drive-In	O.R. Turnpike & Tennyson Rd.	43.33	49.28 Cr.	444.57	13.55		755.55
197	Peisner Bakery & Restaurant	Adams Cafeteria Building			117.62	155.00	59.33 Cr.	1026.33
5-A	Pine Valley Beauty Shop	New York & Utah Avenue			99.92			
3-A	Pine Valley Pharmacy	New York & Utah Avenue	20.92		188.28			
22-R	Portrait Studio	Hostess House, Adams Lane	12.26		172.86			

CP
138-1

	New York Life Insurance Co.	Grove Center
L-295	Oak Ridge Engineers & Scientists	P. O. Box 382
SC-4	Oak Ridge Collection Service	P. O. Box 1228
SC-21	Oak Ridge Housing Company	
	Oak Ridge Rec. & Welfare Assn.	
SC-1	Oak Service Association	P. O. Box 2011
213	O'Connor & Crowe Mtr. Service	Farm Market Area
118	O'Neal Cleaning Co.	Commercial Area
26-C	Outer Drive Market	Outer Drive & Ogden Lane
162	Pan-Am Service Center	O. R. Turnpike & G. V. Rd.
150	Park Service Company	P. O. Box 156
215	Peacock Lodge Drive-In	O.R. Turnpike & Tennyson Rd.
197	Peisner Bakery & Restaurant	Adams Cafeteria Building
5-A	Pine Valley Beauty Shop	New York & Utah Avenue
3-A	Pine Valley Pharmacy	New York & Utah Avenue
82-B	Portrait Studio	Hostess House, Adams Lane
123	R. & H. Valet Shop	Jefferson Circle
110	Radiator Brake & Repair	Coal Yard Road
L-24	Railway Express Agency	
4-A	Reeder Motor Company	Calif. Ave. & O.R. Turnpike
SC-14	Ridenour Management Co.	P. O. Box 391
171	Roach Plumbing & Heating Co.	Lucknow Circle
185	S. & B. Food Market	Robertsville & Seneca
15-B	Schubert Shoe Repair	Jackson Square
34-A	Service Drug Store	Broadway
	Shea Painting Company	P. O. Box 1172
113	Spears Electric Supply Co.	Commercial Area
24-B	Taylor's, Inc.	Broadway
154	Thompsons Beauty Shop	Colored Hutment Section
88	Thrifty Drugs	Grove Center
33-B	Townsite Fountain #1	Jackson Square
79	Townsite Fountain #3	Middletown
SC-5	Tri-State Homes	Jefferson Circle
81	Tuggles Market	Farm Market Area
64	Tuliptown Market	Grove Center
169-A	Turner Motor Service, F.M.Cox (Trico)	
101-A	Turnpike Service Station	O. R. Turnpike & Ill. Ave.
184-A	Tweed & Nichols Garage	Gamble Valley
35-B	Tennessee Optical Company	Broadway
SC-9	Underwood Window Cleaning	P. O. Box 2094
136	The Uniform Shop	S. of Central Cafeteria
48-A	United Cab Company	Tenn. & Towne Avenues
220 G-15	United Gas, Coke & Chem. Workers of America, CIO	
2-A	Vermont Gateway Gas Station	Galesburg Hall
17-A	Victory Beauty Shop	Vermont Ave. & O.R. Turnpike
189	The Waffle Shop	Jackson Square
124	Warren Advertising Company	Grove Center
211	Watson Produce Market	P. O. Box 388
161	West End Service Station	Farm Market Area
Sub-55	Whitson Brothers	Turnpike W. of La. Ave.
22-A	Williams Drug Store	Middletown
191	X.Y.Z. Company	Jackson Square
		Commercial Area

C-13a-2
P2

		144.60		
		.49		
		33.94		
		27.89	214.52	24239.37
			2876.03	18425.86
848.53		7540.23	1198.47	15302.42
			144.50	592.71
20.65		143.92		
	12.16 Cr.	24.95	6.77	545.77
		906.91		
		154.65		
4.15		44.17		3.17
43.33	49.28 Cr.	444.57	13.55	755.55
		117.62	155.00	59.33 Cr. 1026.33
		99.92		
20.92		188.28		
12.26		172.86		
		45.89		29.16
		14.69		21.08
			30.00	50.00
6.67		62.43		
31.30		369.46	95.00	1204.52
		109.54		6.33
		1147.66		
		6.33		
10.16		122.61		
		12.32		
		2.23		
				653.39
		18.00		
65.05		614.45		
		59.89		
17.34		126.21		
				51186.76
		60.63		
179.42		1833.55		
			7.81	70.29
		161.45		
1.14		10.26	6.75	57.09
		.43		
		44.94		
		27.00		
		6.16		
		67.23		
		14.17		
		1.10		
		192.05		
23.64		209.86		334.04
		65.13		
		98.10		
20.08		180.72		
		44.55		
		81.34		

ROANE-ANDERSON COMPANY
CLINTON ENGINEER WORKS
OAK RIDGE, TENNESSEE

EQUIPMENT RENTALS REPORT

DECEMBER 31, 1946

RA NO.	LESSEE	LOCATION	DEC. 1946	ADJUST-MENTS	CUMU-LATIVE	DEC. 1946	ADJUST-MENTS	CUMU-LATIVE
DENTISTS								
205 D-1	Dr. W. B. Burgess	Dental Clinic	26.34		210.72			
D-2	Dr. R. B. White	Dental Clinic			125.92			
D-3	Dr. Frank P. Bowyer	Dental Clinic	91.37		730.96			
D-4	Dr. H. W. Underwood	Dental Clinic			227.40			
D-5	Dr. Leroy Grigsby	Dental Clinic	22.99		206.89			
D-6	Dr. Jack Yearwood	Dental Clinic	29.83		269.01			
D-7	Dr. Clarence Llewellyn	Dental Clinic	26.04		234.34			
D-8	Dr. William A. Squires	Dental Clinic	23.24		185.92			
PHYSICIANS								
210 M-1	Dr. James B. Ridley	Hospital			29.25			
M-2	Dr. R. H. Duewall	Hospital			41.15			
M-3	Dr. John R. Eggleston	Hospital			81.92			
M-5	Dr. Hyman Rossman	Hospital			78.01			
M-7	Dr. Frank Sims Moody	Hospital			78.65			30.00
M-8	Dr. Wm. W. Pugh, Jr.	Hospital			69.95			
M-9	Dr. Cordell H. Williams	Hospital			55.52			
M-10	Dr. Parley V. Dings	Hospital			61.18			
M-11	Dr. Harry C. Helm	Hospital	8.39		95.04			
M-12	Dr. Thos. F. Stevens	Hospital	7.36		71.23			
M-13	Dr. R. W. Price	Hospital	8.31		73.13			
M-16	Dr. Carl A. Whitaker	Hospital			15.40			
M-17	Dr. Henry A. Brsostowski	Hospital			33.35			
M-19	Dr. R. G. Tromly	Hospital	7.41		48.99			
M-20	Oak Ridge Health Team	Dental Clinic	41.13	335.04 Dr.	376.17			

Q13a-1 P3

M-8	Dr. Wm. W. Pugh, Jr.	Hospital		78.65		30.00
M-9	Dr. Cordell H. Williams	Hospital		69.95		
M-10	Dr. Parley W. Dings	Hospital		55.52		
M-11	Dr. Harry C. Helz	Hospital		61.18		
M-12	Dr. Thos. F. Stevens	Hospital	8.39	95.04		
M-13	Dr. R. M. Price	Hospital	7.36	71.23		
M-16	Dr. Carl A. Whitaker	Hospital	8.31	73.13		
M-17	Dr. Henry A. Brzostowski	Hospital		15.40		
M-19	Dr. R. G. Trowly	Hospital		33.35		
M-20	Oak Ridge Health Assn.	Dental Clinic	7.41	48.99		
M-21	Dr. E. M. Dings	Hospital	41.13	376.17	335.04 Dr.	
M-22	Dr. Dana W. Nance	Hospital	8.78	52.68		
M-23	Dr. Henry E. Ruley	Hospital		52.32		
M-24	Dr. Albert C. Frell	Hospital		75.00		
				25.43		

\$ 2,168.73 \$ 5.62 Dr. 27,541.55 \$ 7,362.22 \$59.33 Cr. \$ 143,460.92

NOTE: THIS REPORT IS FOR STATISTICAL PURPOSES AND DOES NOT PURPORT TO REPRESENT CONTROL OF REVENUE.

SC - Sub-Contract
 L - License Agreement
 SUB - Sub-Concessionaire

V. A. Taylor
 V. A. Taylor/
 Asst. Chief/Accountant

P13
 C-15a-2

C-14 ROANE-ANDERSON COMPANY ORGANIZATIONAL CHART, 1944

**ROANE-ANDERSON COMPANY OPERATIONS
1944**

**PROJECT
MANAGER**

A. SUPERVISORY

Project Office
Intelligence & Safety
Division of Utilities
Division of Operations
Division of Maintenance
Division of Accounts

Dept. of Engineering

B. DIVISION OF UTILITIES

Electric Power & Light
Water Supply
Steam Plant & Distribution
Sewerage & Disposal Plant
Telephone
Warehouse
Utilities Machine Shop

C. DIVISION OF OPERATIONS

Laundries
Cafeterias
Dormitories
Efficiency Apartments
Guest House
Homes
Business Concessions
Farms
Hospital
Medical Center
Barracks
Warehouse Supplies

Western Union
Purchasing

D. DIVISION OF MAINTENANCE

Transportation
General Cleaning - Bldgs.
Ash & Garbage Collection
Coal & Lumber Distribution
Bldg. & Home Maintenance
Police Department
Fire Department
Stables

E. DIVISION OF ACCOUNTS

Timekeeping Department
Payroll Department
Paymaster
Finance
Cashier
Accounts Payable Dept.
Accounts Receivable
Audit Department
Cost Department
Property Department

~~SECRET~~

G-15 ROANE-ANDERSON COMPANY ORGANIZATIONAL CHART, 1945

~~SECRET~~
ROANE-ANDERSON COMPANY OPERATIONS
1948

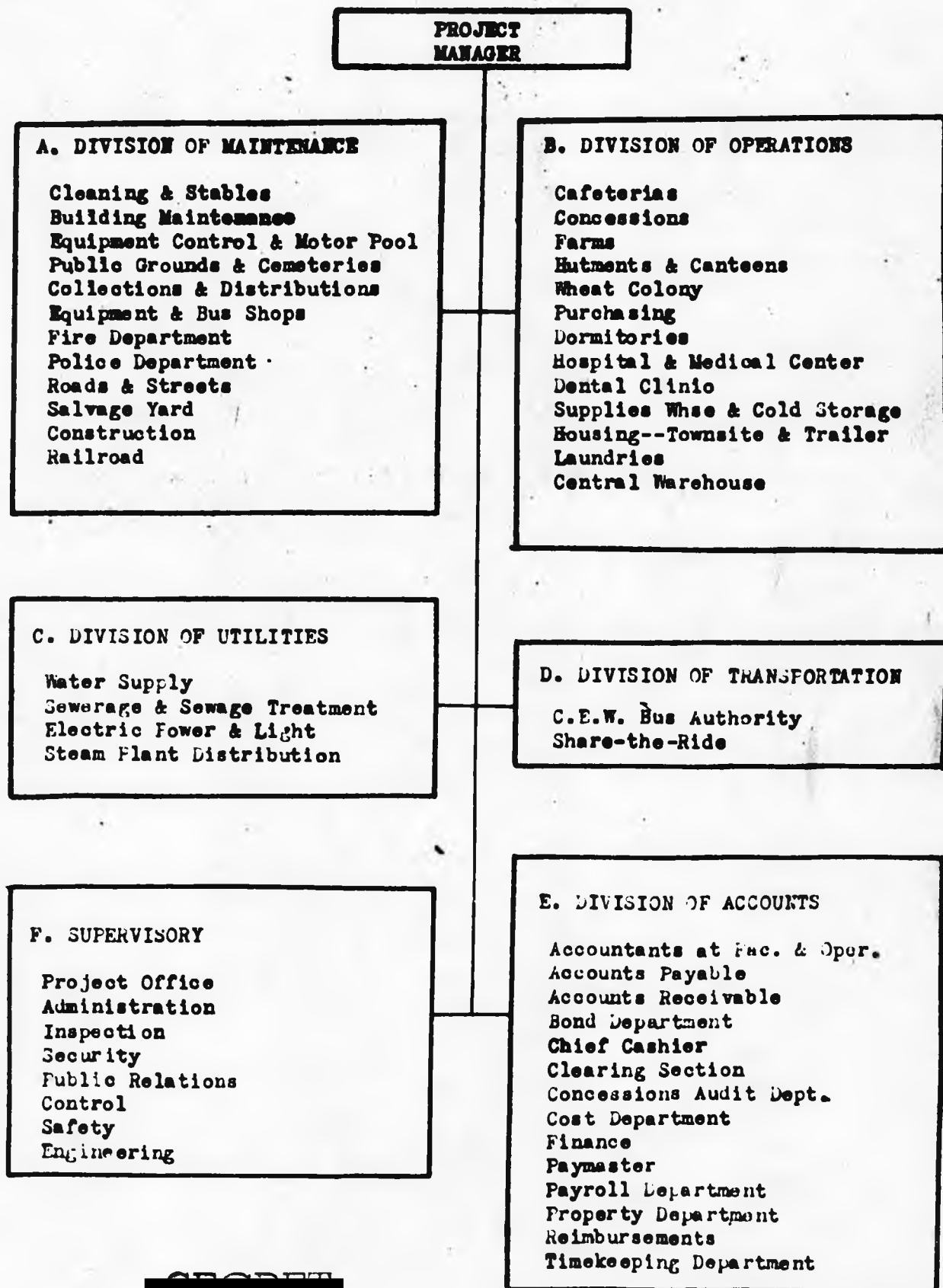

BOATE - ANDERSON COMPANY

PROJECT OFFICE
 GEORGE E. HORR
 NON-RESIDENT PROJECT MGR
 CLINTON N. HERNANDEZ
 PROJECT MANAGER
 E. D. WORRELL - ASST. PROJ. MGR.

ADMINISTRATIVE ASS'T
 A. W. FOLSOM - OFF. ENGR.

DIVISION OF ADMINISTRATION
 L. D. WORRELL - MGR. OF ADM'N
 J. E. BROCK - ASST TO MGR. OF ADM'N

PURCHASING DEPT.
 W. H. LEEDOM - CH'F PURCH. AGT.

DIVISION
 S. J. DAVIS

R. A. CO. - HOUSING SECURITY
 J. E. BROCK - ASST. TO MGR. OF ADM'N

EMPLOYMENT-PERSONNEL
 CITY DIRECTORY
 OFFICE SERVICES
 FORMS - STATIONERY
 & REPRODUCTION
 PROCESSING OF COM'L EMPL.
 M. M. MARSHALL - EMPL. & PERS'L SUPV.

SAFETY DEPT.
 F. M. LIVINGSTON - SAFETY ENG.

LIAISON ONLY
POLICE DEPT.
 LT. COL. D. G. WILLIAMS

GUARD DEPT.
 LT. COL. D. G. WILLIAMS

FIRE DEPT.
 LT. COL. D. G. WILLIAMS

HOSPITAL - MEDICAL & PUBLIC HEALTH
 DR. L. SALISBURY - DIRECTOR

SCHOOL SYSTEM
 DR. A. H. BLANKENSHIP - SUPV.

MANDATORY PER'L
 W. C. ROTHERMEL

OPERATION DEPTS.

CONCESSIONS DIVISION
 F. W. COOK - MANAGER

BLDG. MAINTENANCE
 W. VAN FLEET - GEN'L SUPT.

CENTRAL WAREHOUSES
 N. J. HOLLAND - GEN'L SUPT. WH.

CONCESSIONS DEPT.
 B. H. HAGEDORN - CONTR. SUPV.

PROMOTION & CONTR. ACTS SECTION
 C. M. WINFREY - CONTR. SUPV.

CONSTRUCTION
 M. CARLSON - SUPT.

**EQUIPMENT SHOPS
 EQUIPMENT CONTROL & MAINTENANCE**
 H. SCHMITZ - MANAGER

**ROADS & STREETS
 PUBLIC GROUNDS**
 C. MARTIN - MANAGER

**EXCESS MATERIALS & EQUIPMENT
 SALVAGED MATERIALS**
 S. FULLER - MANAGER

ORGANIZATION CHART

OFFICE
 PROJECT MGR.
 NANDEZ
 MANAGER
 PROJECT MGR.

COMPTROLLER
 R. E. CALLAHAN - COMPTROLLER

DIVISION OF AUDIT
 J. J. DAVIS - ASST CH'F ACCT

DIVISION OF ACCOUNTS
 M. K. WALSH - MGR. DIV. OF ACCT'S
 R. W. HAMER - ASS'T MGR. DIV. OF AC.

COST & INSURANCE
 R. EICHORN - ASS'T CH'F ACCT

ACCTS. REC. & COLLECTIONS
 F. D. SNODGRASS - SUPV.

FINANCIAL & GENERAL
 ACCT. CONTROL
 C. R. PERRY - ASS'T CH'F ACCT

ACCOUNTS PAYABLE
 S. FREEMAN - AC. PAY. SUPV.

TIMEKEEPING
 & PAYROLL
 C. J. METZLER - SUPT. P/R, TIME, PAYMAS.

PROPERTY
 W. J. CARROLL - SUPT OF PROP. SEC.

REVENUE ACCOUNTS
 C. O. CARPENTER - ASS'T CH'F ACCT

REIMBURSEMENTS -
 PUBLIC VOUCHERS
 F. B. BATES - ACCOUNTANT

SUB-CONTRACT ACCT. &
 CONCESSIONS AUDIT
 V. A. TAYLOR - ASS'T CH. ACCT

S DIVISION
 MANAGER

UTILITIES DIVISION
 B. D. MANCHESTER - MGR. DIV. OF UTIL.

CONTR-
 TION
 NTR. SUPV.

SUB-CONTRACT DEPT.
 T. R. DISBROW - SUB-CONT. SUPV.

WATER-SEWER-HEATING
 PLANT MAINTENANCE
 J.M. RUSSELL - ASST. TO MGR. OF UTIL.

ELECTRICAL
 L. G. COLSON - ASST. TO MGR. OF UT.

ROANE-ANDERSON COMPANY

WAR DEPARTMENT CONTRACT-W7401-ENG.115

RESTRICTED

This document contains information affecting the national defense of the United States, within the meaning of the Espionage Act, U. S. C. 50, 31 and 32. Its transmission or the revelation of its contents in any manner to an unauthorized person is prohibited by law.

APPROVED *Charles W. Newman* JULY 1, 1946
 PROJECT MANAGER

C-16-2

C-17 CENTRAL FACILITIES ORGANIZATIONAL CHART, MARCH 1943

SECRET

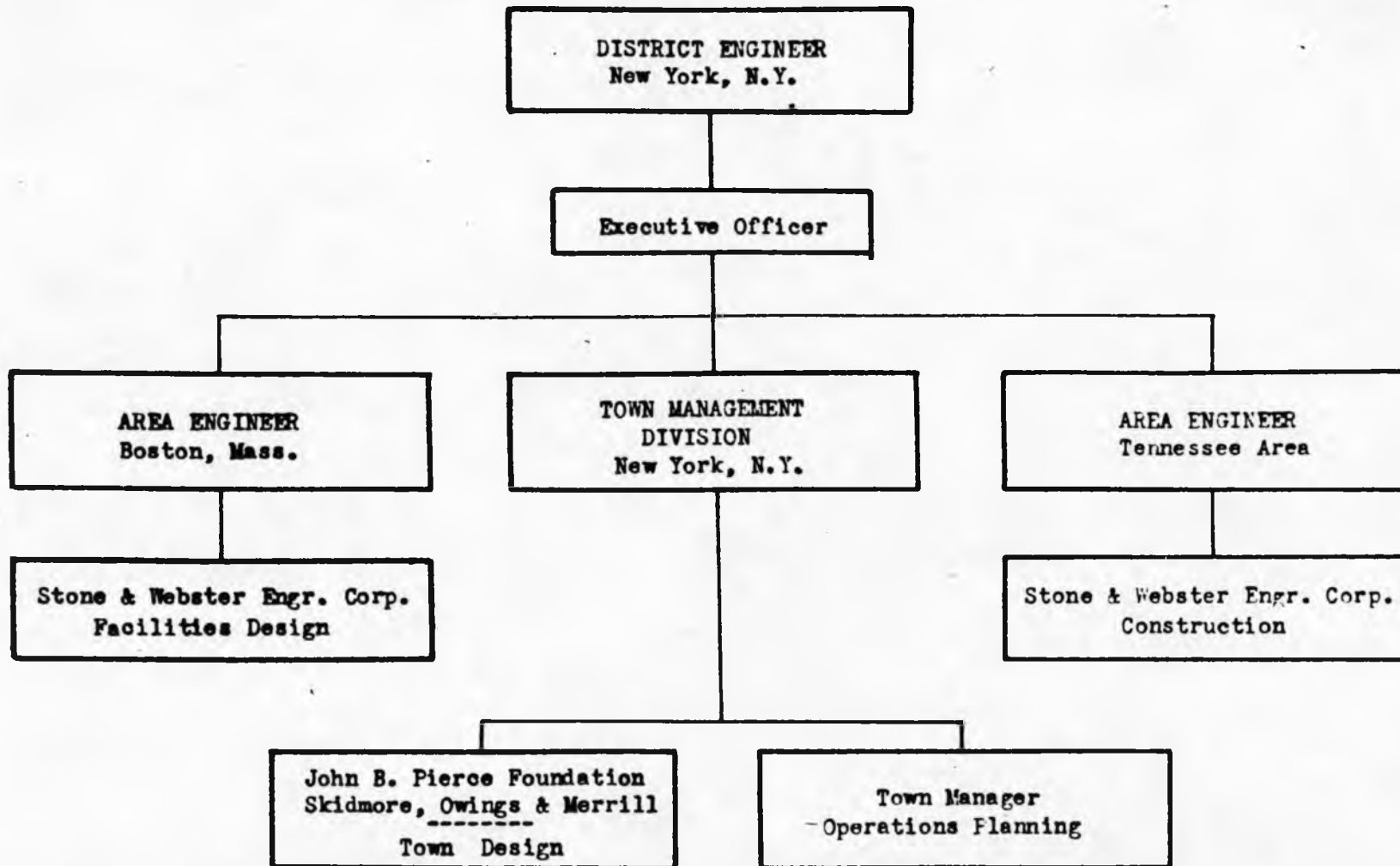

CENTRAL FACILITIES ORGANIZATION

MARCH, 1943

C-18 CENTRAL FACILITIES ORGANIZATIONAL CHART, MARCH 1944

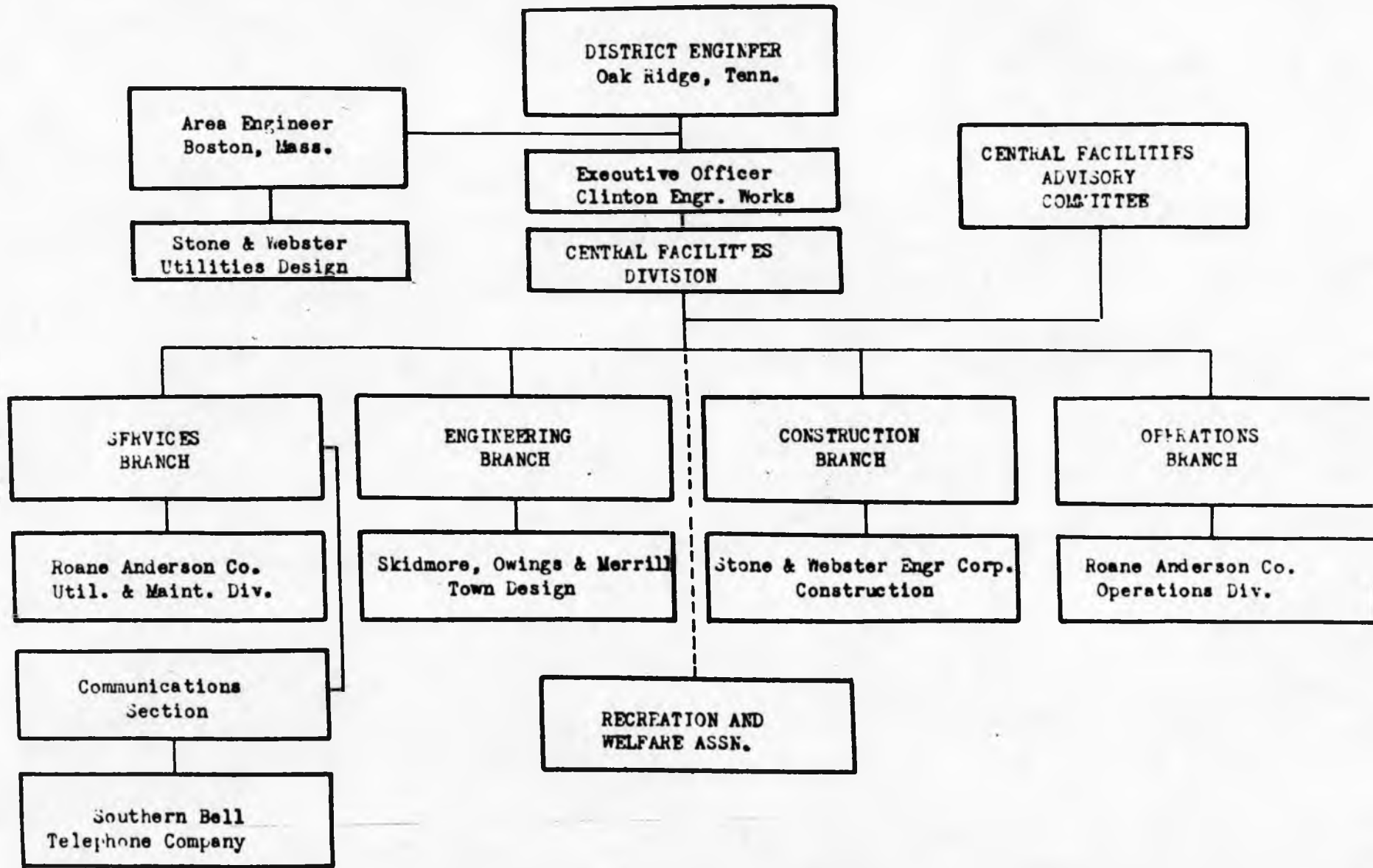

CENTRAL FACILITIES ORGANIZATION

MARCH, 1944

G-19 CENTRAL FACILITIES ORGANIZATIONAL CHART, MARCH 1945

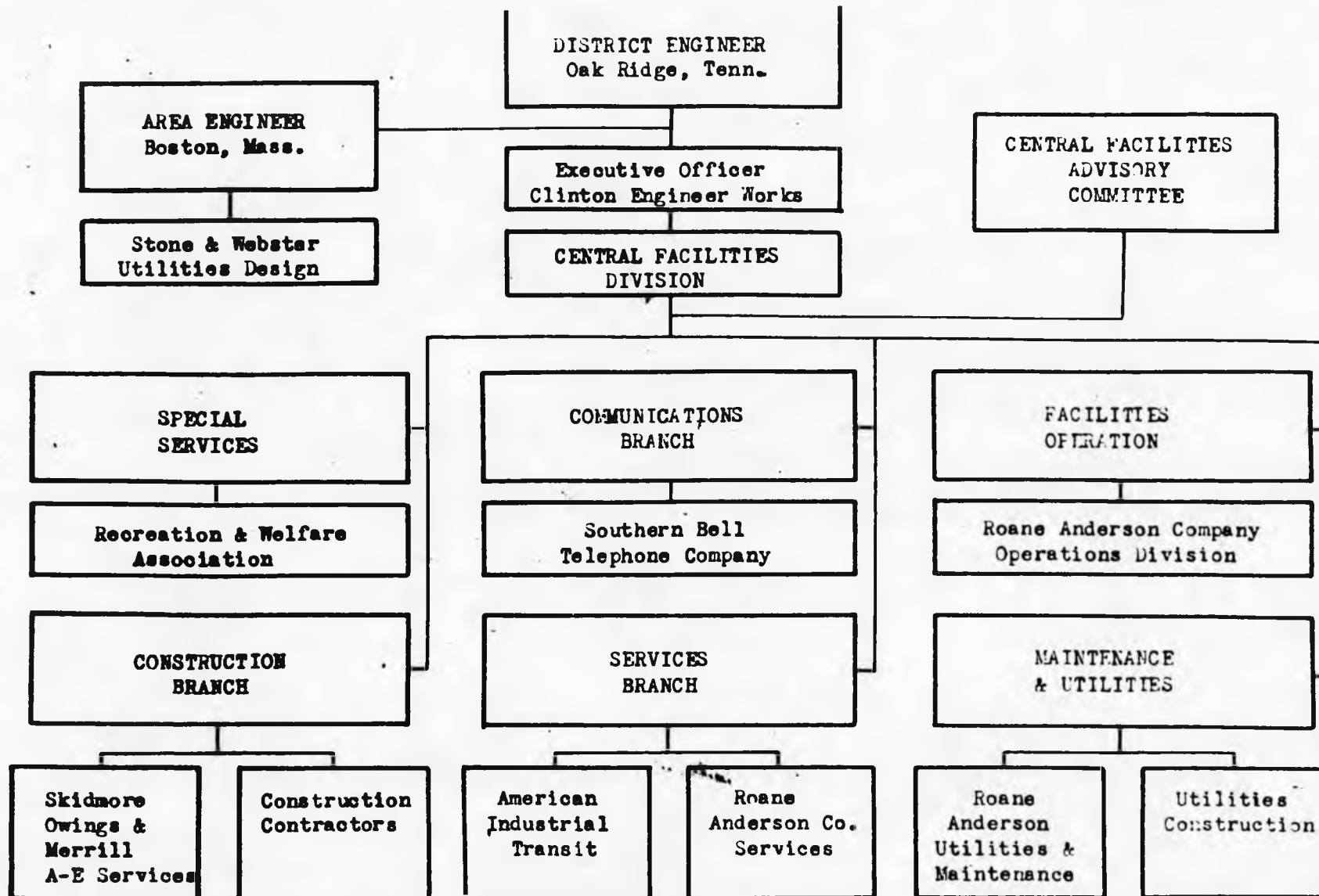

CENTRAL FACILITIES ORGANIZATION
MARCH, 1945

C-20 FACILITIES AND SERVICE DIVISION ORGANIZATIONAL CHART,

16 MAY 1946

OFFICERS
 ENL.....
 P.....
 S P.....
 C A P.....
 C P C.....
 MISCL.....
 VAC.....
 TOTAL.....

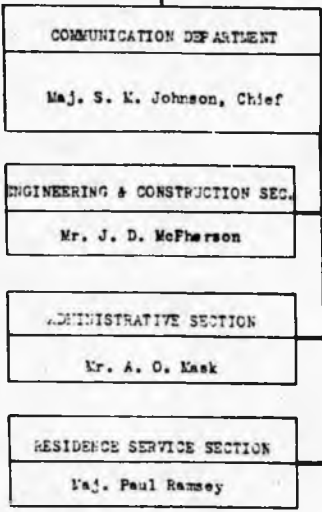
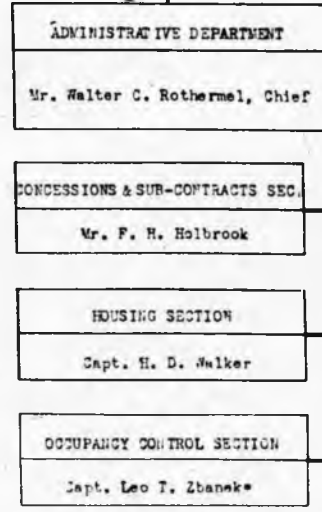
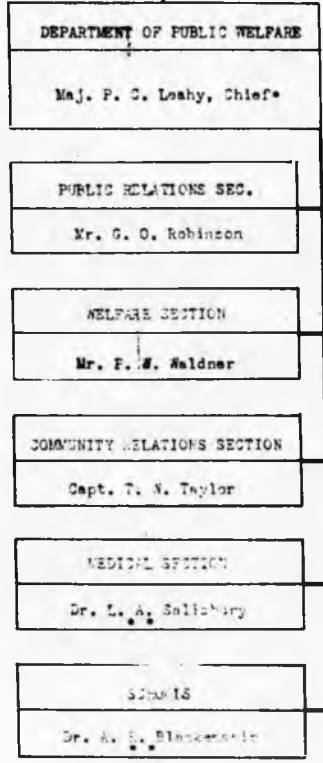
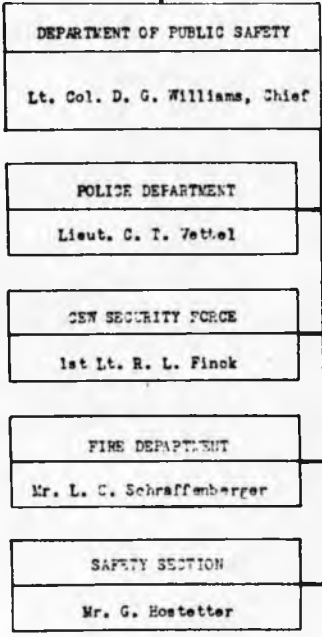
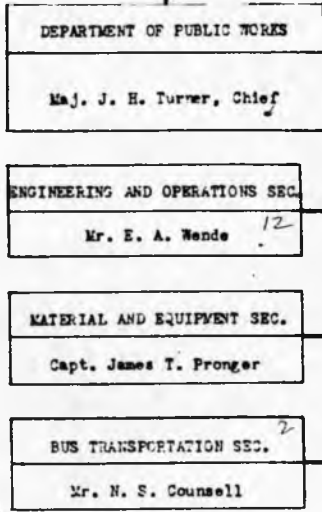
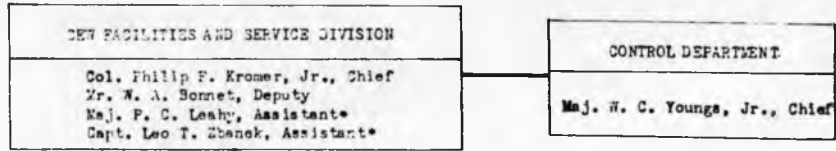

ORGANIZATION CHART
 MANHATTAN DISTRICT

UNIT: DEW FACILITIES AND SERVICE DIVISION

SUBMITTED *William A. Bernet* DATE *5/16/46*

RECOMMENDED *Philip D. ...* DATE *5/16/46*

APPROVED *[Signature]* DATE *5/16/46*

* Dual Capacity
 ** Not U.S.E.D. Employee

C-21 MANHATTAN DISTRICT ORGANIZATIONAL CHART, 1 APRIL 1943

DISTRICT ENGINEER
DEPUTY DISTRICT ENGINEER
EXECUTIVE ASSISTANT

TECHNICAL STAFF
Director - Lt. Col. Nichols
Ex. Asst. - Dr. Wensel
Dr. Warren Maj. Peterson
Maj. Friedell Maj. Hough
Maj. Ruhoff Capt. Fidler
2 others

U. OF CH
Maj. Peter
COLUMBIA
Maj. Hough
U. OF CA
Capt. Fidler

PROJECT DIRECTOR
X-10, P-9, SPEC. MAT.
Lt. Col. Nichols

PROJECT
K-25
Lt. Col.

P-9 UNIT CHIEF
Capt. Traynor

X-10 UNIT CHIEF
Lt. Col. Matthias
Maj. Travis

Y-12 UNIT CHIEF
Maj. Kelley

TRAIL
Maj. Sally

HANFORD E. W.
Lt. Col. Matthias
Lt. Col. Kadlec

BOSTON
Capt. Swanson

WABASH
Maj. Rosback

WILMINGTON
X-10 ONLY
Maj. Sapper

CLINTON E. W.
Y-12 ONLY
Lt. Col. George

MORGANTOWN
Maj. Brinkman

CHICAGO (LIAISON)
Maj. Peterson

SPECIAL ACCTS.
Capt. Powers

ALABAMA
Capt. Wells

COLUMBIA (LIAISON)
Maj. Hough

CLINTON E. W.
X-10 SEMI WORKS
Lt. Col. George
Capt. Grafton
(CONSTRUCTION)

CALIFORNIA (LIAISON)
Capt. Fidler

SPECIAL MATERIALS
Lt. Col. Crenshaw
Maj. Ruhoff

ALL SPECIAL MATERIAL AREAS

Liaison
Only

Design & Operation

CLINTON E. W. -
DEP. DIST. ENGR.
EXEC. ASST.

ENGINEERING DIV.

ADMINISTRATIVE DIV.

SERV. & CONTROL DIV.

K-25, OPER. DIV.
Col. Stowers

X-10 SEMI WKS. OP. SERV.

~~RESTRICTED~~

C-21

C21-1

CT ENGINEER - Col. Marshall
 DISTRICT ENGINEER Lt. Col. Nichols
 IVE ASSISTANT - Lt. Col. Blair

~~CONFIDENTIAL~~
 CONFIDENTIAL

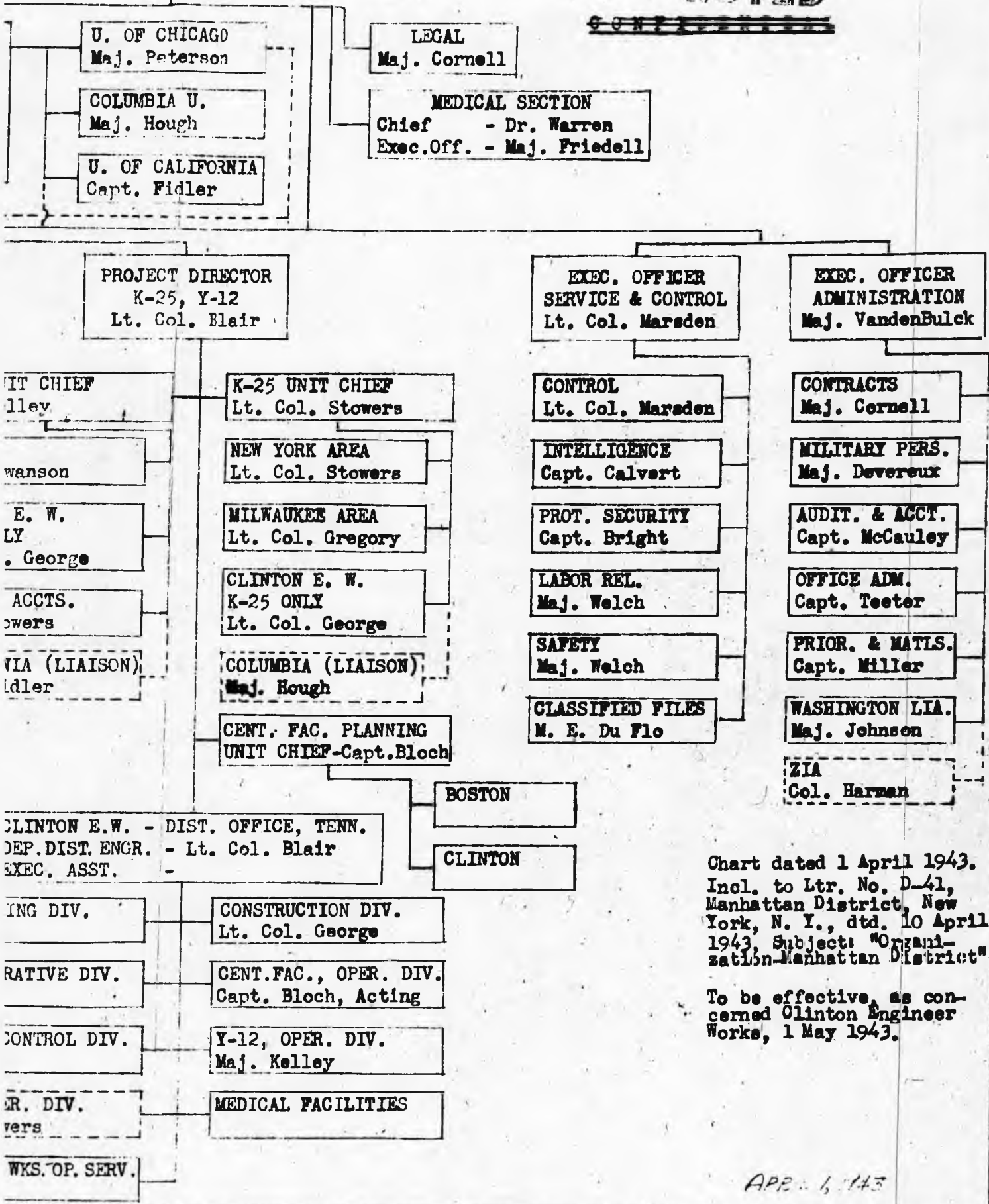

Chart dated 1 April 1943.
 Incl. to Ltr. No. D-41,
 Manhattan District, New
 York, N. Y., dtd. 10 April
 1943, Subject: "Organi-
 zation-Manhattan District"

To be effective, as con-
 cerned Clinton Engineer
 Works, 1 May 1943.

APR 6 1943

G-2 FACILITIES AND SERVICE DIVISION ORGANIZATIONAL CHART,

5 NOVEMBER 1946

PERSONNEL

OFFICERS	24
Ungraded	194
ENL.	212
P	61
S P	100
CAP	227
CPC	73
** MISCL	513
New	12
VAC.	74
TOTAL	1521

CEW FACILITIES AND SERVICE DIVISION
 Col. Philip P. Kromer, Jr., Chief
 Mr. W. A. Bonnet, Deputy Chief
 Maj. W. C. Palfreyman, Exec. Officer

CONTROL DEPARTMENT
 Maj. W. C. Youngs, Jr., Chief

DEPARTMENT OF PUBLIC WELFARE
 Maj. H. C. Flowers, Chief

COMMUNICATIONS DEPARTMENT
 Maj. Paul Ramsey, Chief

DEPARTMENT OF PUBLIC SAFETY
 Lt. Col. D. G. Williams, Chief

ADMINISTRATIVE DEPARTMENT
 Mr. Walter C. Rothermel, Chief

DEPARTMENT OF PUBLIC WORKS
 Mr. E. A. Wende, Chief

PUBLIC RELATIONS SEC.
 Mr. G. O. Robinson

ENGINEERING & CONSTRUCTION SEC.
 Mr. James D. McPherson

CEW SECURITY FORCE
 Capt. H. F. Hall

CONCESSIONS & SUBCONTRACTS SEC.
 Mr. F. H. Holbrook

ENGINEERING & OPERATIONS SEC.
 Mr. L. H. Jackson

COMMUNITY RELATIONS SECTION
 Mr. J. E. Torrence

SERVICE AND CONTROL SECTION
 Capt. G. L. Agnor*

POLICE DEPARTMENT
 Mr. C. T. Vettel

HOUSING SECTION
 Capt. H. D. Walker

MATERIAL AND EQUIPMENT SEC.
 Maj. James T. Pronger

WELFARE SECTION
 Mr. P. W. Waldner

TELETYPE, TELEGRAPH AND CRYPTOGRAPH SECTION
 Mr. W. C. Evans

FIRE DEPARTMENT
 Mr. L. G. Schraffenberger

OCCUPANCY CONTROL SECTION
 Mr. Raymond S. Stripling

BUS TRANSPORTATION SEC.
 Mr. N. S. Counsell

HOSPITAL
 Dr. L. A. Salisbury

RECORDS SECTION
 Capt. G. L. Agnor*

SAFETY SECTION
 Mr. G. M. Hostetter

SCHOOLS
 Dr. A. H. Blankenship

TRAFFIC SECTION
 Mrs. Mildred L. Haggard

PUBLIC HEALTH SECTION
 Dr. Charles H. Beming

COMMUNICATIONS SERVICE ACCOUNTS SECTION
 Mr. Gerald L. Button

RECREATION & WELFARE ASSOCIATION
 Mr. Swep T. Davis

ORGANIZATION CHART
 MANHATTAN DISTRICT

UNIT: CEW FACILITIES AND SERVICE DIVISION

SUBMITTED: *William A. Bonnet* DATE: 11/4/46

RECOMMENDED: *W. A. Bonnet* DATE: 11/1/46

APPROVED: *William A. Bonnet* DATE: 11-5-46

* Dual Capacity
 ** Not U.S.E.D. Payroll

C-22

PERSON
 OFFICERS 2
 ENL.....
 P.....
 S P.....
 CAF..... 2
 CPO.....
 MISCL.....
 VAC..... 1
 TOTAL..... 5

**CEW FACILITIES & SERVICE DIVISION
 (DIVISION OFFICE)**

Col. Philip P. Kromer, Jr., Chief

Responsible for the engineering, design, construction, administration, maintenance, and management of the Clinton Engineer Works, exclusive of the plant areas.

Manages the town of Oak Ridge which includes, the operation and maintenance of all utilities in the townsite area including sewage system, sewage treatment plant, electric distribution system, communications, transportation services, roads, and streets. Supervises the operation of all concessions and businesses such as restaurants, cafes, grocery stores, laundries, etc. Provides and maintains medical, public health, safety, fire and police protection facilities. Operates and maintains the public school system, hospitals, and playgrounds. Maintains houses, dormitories, and all buildings in the townsite area. Supervises the community relations and all recreational welfare activities.

Determines policy on expenditures and operations of contractors and contractor employees.

Mr. W. A. Bonnet, P-6, Deputy Chief
 Maj. W. C. Palfreyman, Executive Officer
 Miss Alice Cowan, CAF-6, Secretary
 Miss Dola A. Weaver, CAF-4, Clerk-Steno.
 1 CAF-4, Clerk-Steno, Vacant

**ORGANIZATION CHART
 MANHATTAN DISTRICT**

CEW FACILITIES & SERVICE DIVISION
 UNIT DIVISION OFFICE

SUBMITTED *William A. Bonnet* DATE *7/4/46*
 RECOMMENDED *W. Palfreyman* DATE *4/14/46*
 APPROVED *W. Palfreyman* DATE *11-5-46*

C-22

0-23 COMMUNICATIONS DEPARTMENT ORGANIZATIONAL CHART,

10 OCTOBER 1946 (4 Sheets)

PERL.....
 OFFICERS 2
 ENL.....
 P..... 3
 S P.....
 CAP..... 72
 CPC.....
 MISCL.....
 VAC..... 12
 TOTAL..... 87

* Dual Capacity

COMMUNICATIONS DEPARTMENT

MAJOR PAUL RAMSEY, CHIEF.

Responsible for planning, installation and operation of all telephone facilities at CEW. Advises the Chief of Facilities and Service Division on policy matters affecting all phases of telephone operation. Coordinates all details affecting the operation of the Western Union Telegraph Co. Supervises all phases of the operation of Government leased TWX machines. Cryptographic Officer.

Captain G. L. Agnor, Assistant Chief. *
 Miss Mary J. Palmer, Clerk-Typist, CAF-4.
 Mrs. Elizabeth P. Hastings, Secretary (Stenog.), CAF-4.

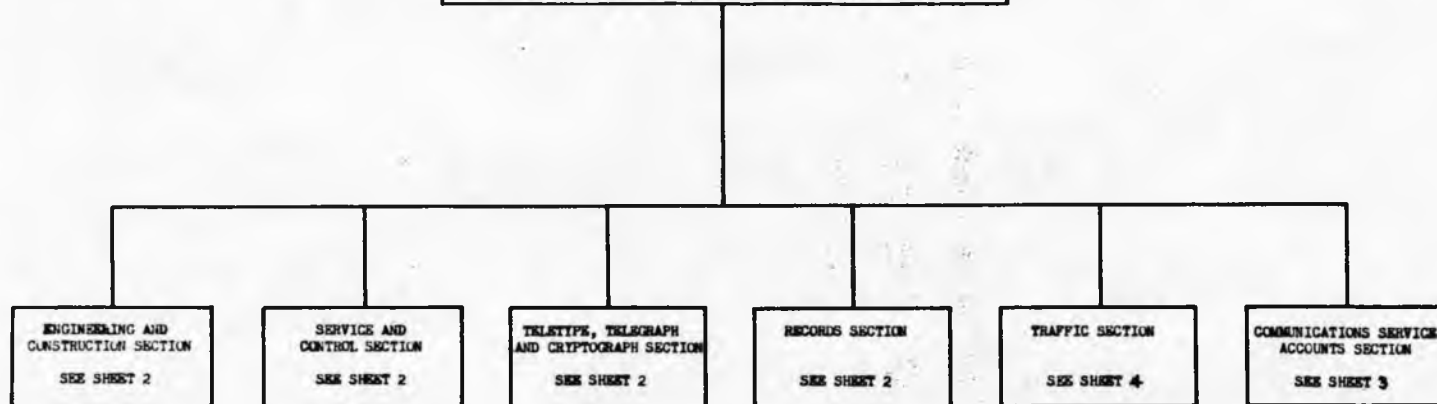

ORGANIZATION CHART
MANHATTAN DISTRICT
 CEW FACILITIES AND SERVICE DIVISION,
 UNIT COMMUNICATIONS DEPARTMENT.

SUBMITTED BY *[Signature]* DATE 2 Oct 46
 RECOMMENDED BY *[Signature]* DATE 8/9/46
 APPROVED BY *[Signature]* DATE 10-10-46

PERSONNEL

OFFICERS	
EGL.	7
P.	7
SP	7
CAP	7
CPG	
MISCL.	1
NEW	4
VEC.	
TOTAL	26

SAFETY SECTION

Mr. G. H. Hestetter, P-4, Chief

Responsible for the Administration and operation of the Safety and Accident Prevention Program for the C.E.W. Facilities and Service Division.

Mr. L. L. Kelly, Jr., P-3, Asst.
 1 - Clerk-Stenographer, CAP-4
 1 - Clerk-Stenographer, CAP-3

TRAINING SUB-SECTION

Mr. G. H. Paravis, Engr., P-3, Chief

Responsible for the testing of all drivers of government vehicles operating on the C.E.W. Prepares training programs for drivers and other safety training procedures.

OCCUPATIONAL SUB-SECTION

Mr. C. E. Sims, Engr., P-3, Chief

Responsible for the administration of an occupational Safety Program for all contracts operating under the CEW Facilities and Service Division. Also commissionaires having an occupation type of concession.

Mr. John Stark, Insp.(Safety), SP-3

TRAFFIC SUB-SECTION

Mr. L. A. Norman, Engr., P-3, Chief

Responsible for traffic engineering at Oak Ridge. Check on design and layouts of roads and streets in Oak Ridge to insure a safe and orderly movement of vehicular and pedestrian traffic throughout the project.

Mr. C. M. Cumins, Insp.(Safety), SP-3

COMMUNITY SUB-SECTION

Mr. L. L. Kelly, Jr., Engr., P-3, Chief

Responsible for the administration of the Community Safety Program for the City of Oak Ridge which includes schools, concessions, public buildings, hospital, Police Dept., Fire Dept., facilities, organizations and related public safety.

Mr. T. W. Dwyer, Engr., P-2

**GOVERNMENT PERMIT UNIT
EAST DIVISION ROAD**

Mr. H. H. Walls, Insp., SP-3, Chief
 1 - Insp. (Safety), SP-7
 1 - Insp. (Safety), SP-6
 2 - Clerk-Typists, CAP-3

**GOVERNMENT PERMIT SUB-UNIT
K-25**

1 - Insp. (Safety), SP-7
 1 - Insp. (Safety), SP-6

ACCIDENT INVESTIGATION SUB-SECTION

Mr. Wyron H. Kiser, Inv., CAP-11, Chief

Responsible for the coordination of all motor vehicle accident investigation for CEW. Analyzes accident reports and prepares weekly and monthly accident summaries showing trend and location of motor vehicle accidents.

2 - Clerk-Typists, CAP-3

FIRE ENGINEERING AND EDUCATION SUB-SECTION

Mr. W. E. Mills, Engr., P-3, Chief

Provides coordination and stimulus for public promotional and educational work, furnishes fire prevention engineering inspections. Assists Dept. of Public Works in checking the planning, design or alterations of new or existing structures.

1 - R. A. Mandatory

PUBLIC SAFETY LAW

1 - Chief Safety Insp., CAP-6 (New)

Makes periodic safety inspection of all private vehicles at CEW semi-annually and maintains registration file.

2 - Safety Insp. CAP-5 (New)
 1 - Clerk-Typist, CAP-3 (New)

**ORGANIZATION CHART
MANHATTAN DISTRICT
C.E.W. FACILITIES AND SERVICE DIVISION
Department of Public Safety
UNIT Safety Section**

SUBMITTED *[Signature]* DATE 1 Oct 1946
 RECOMMENDED *[Signature]* DATE 6/19/46
 APPROVED *[Signature]* DATE 12/1/46

* - Dual capacity

C-24

ENCL.
P. 1
SP.
CAP.
CPG.
MISCL. 161
VAC.
TOTAL 162

FIRE DEPARTMENT

Mr. Louis G. Schraffenberger, Comm., P-6

Provides fire protection for the Town of Oak Ridge and responds on extra alarms and special calls in the plant area. Contacts fire hazard and related matter inspection service in all buildings on area.

Mr. Troy O. Richardson, Dep. Comm. **

FIRE PREVENTION INSPECTION SECTION**

Mr. J. S. Pullen, Jr., Chief Fire Inspector

Conducts periodic inspections and spot checks in the area. Is in charge of placement of all First Aid Extinguishers, and refilling thereof.

1 - Asst. Chief Fire Insp.
10 - Fire Inspectors
1 - Secretary

FIRE PROTECTION SECTION**

Mr. Troy O. Richardson, Dep. Comm.*

Provides fire protection and building inspection (fire hazard and related matters) for the Town of Oak Ridge. Responds to Plant Areas on extra alarms and special calls.

1 - Fire Chief
1 - Asst. Chief

SERVICE AND RECORDS SECTION**

Mr. Troy O. Richardson, Dep. Comm.*

Maintains Fire Department records, provides service functions including all supplies and maintenance.

1 - Office Supervisor
1 - Secretary
1 - Clerk
1 - Mechanic Foreman
2 - Mechanics
5 - Dispatchers

OAK RIDGE UNIT**

2 - Asst. Chiefs (Nattalion)

Consists of 10 fire companies with following personnel.

20 - Captains
21 - Sr. Firefighters
68 - Firefighters

WEST OAK RIDGE UNIT **

2 - Acting Asst. Chiefs (Nattalion)

Consists of 2 fire companies with following personnel.

3 - Captains
9 - Sr. Firefighters
9 - Firefighters

* Dual Capacity
** RA Payroll

ORGANIZATION CHART

MANHATTAN DISTRICT

C.F.W. FACILITIES AND SERVICE DIVISION
Department of Public Safety
UNIT Fire Department

SUBMITTED: [Signature] DATE: APR 1966

RECOMMENDED: [Signature] DATE: [Signature]

APPROVED: [Signature] DATE: [Signature]

PERSONNEL	
OFFICERS	
EOL	1
P	
S P	
CAF	1
CPC	
MISCL	153
VAC	
TOTAL	155

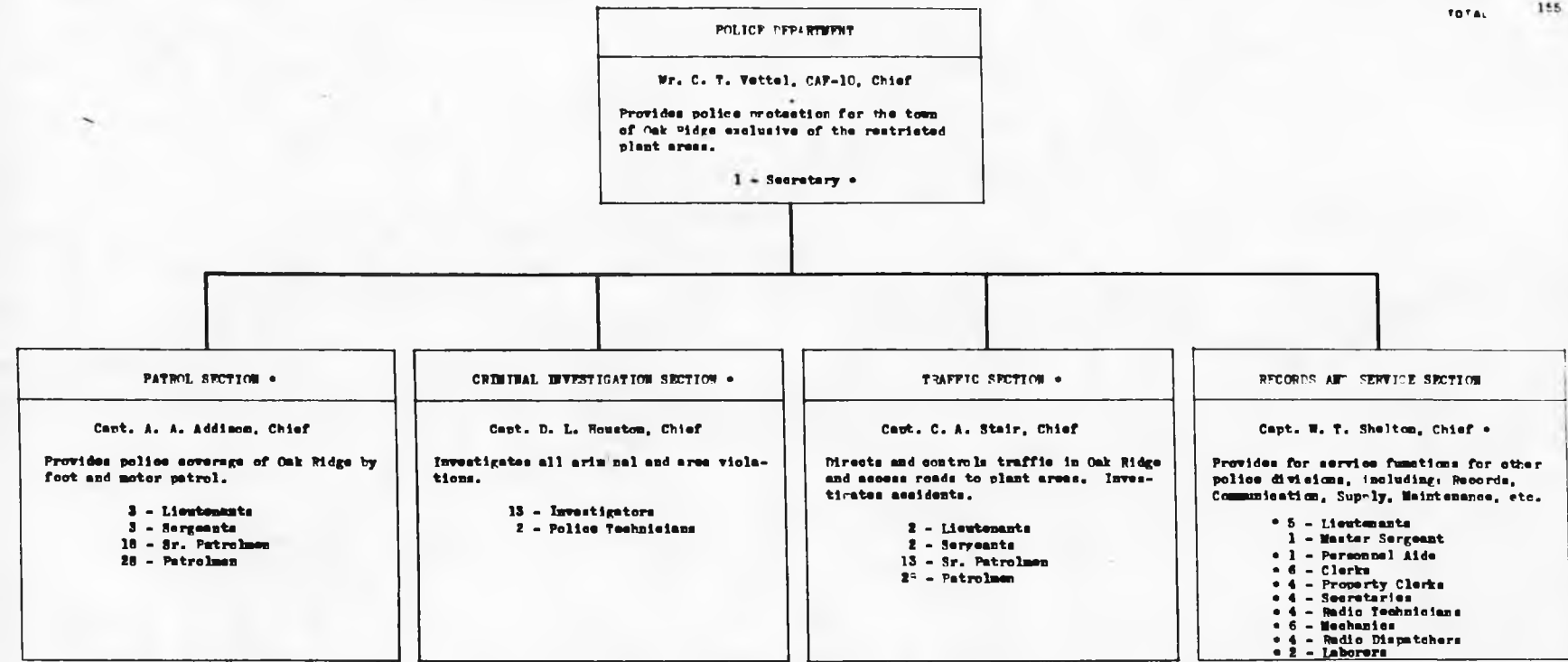

• - BA Payroll

ORGANIZATION CHART
 MANHATTAN DISTRICT
 C.E.W. FACILITIES AND SERVICE DIVISION
 Department of Public Safety
 UNIT - Police Department
 SUBMITTED *[Signature]* DATE 10/25/40
 RECOMMENDED *[Signature]* DATE 10/25/40
 APPROVED *[Signature]* DATE 10/25/40

PERM
 OFFICERS 5
 ENL 110
 P
 SP
 CAP 5
 OPS
 MISCL 208
 VAC
 TOTAL 430

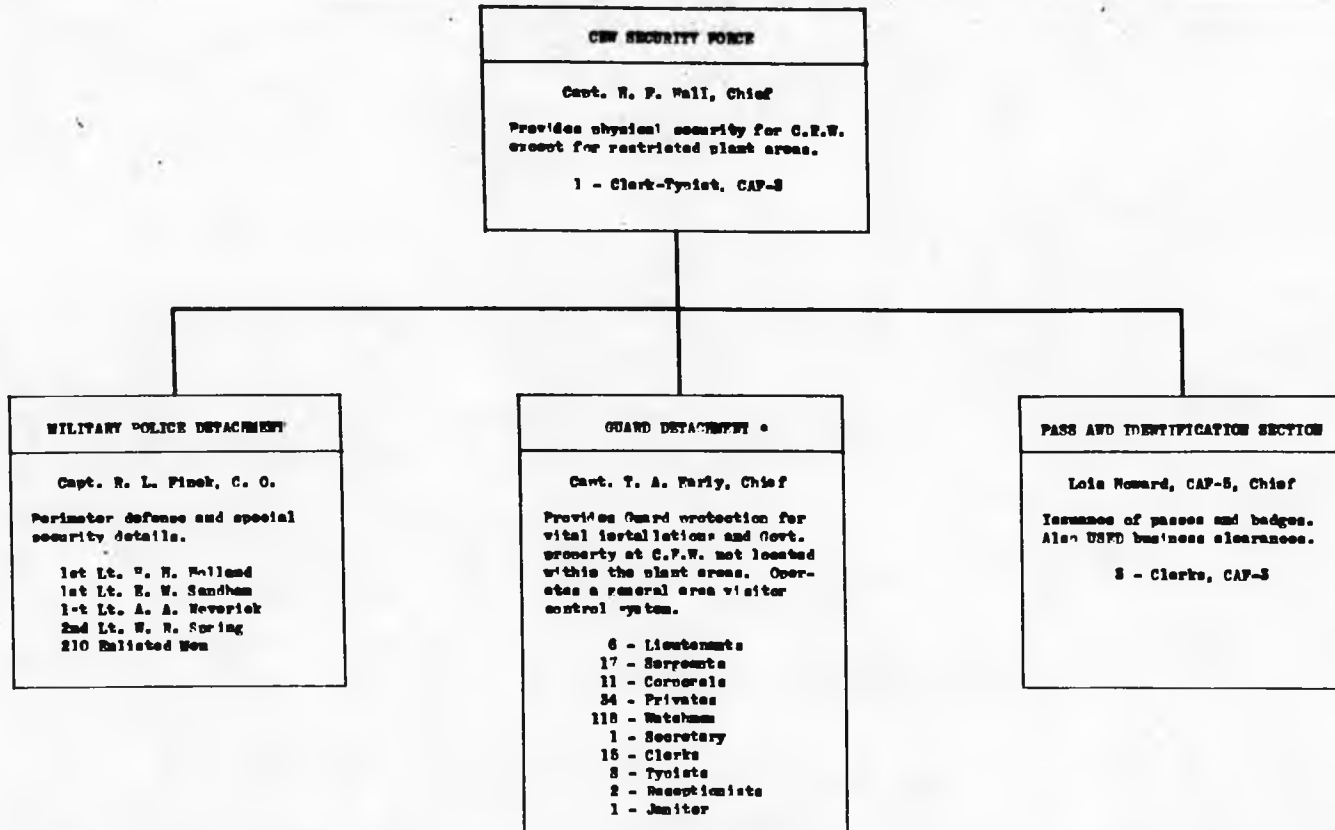

• - RA Payroll

ORGANIZATION CHART
MANHATTAN DISTRICT
 C.E.W. FACILITIES AND SERVICE DIVISION
 Department of Public Safety
 UNIT C.E.W. Security Force

SUBMITTED: [Signature] DATE 10/19/46
 RECOMMENDED: [Signature] DATE 8/19/46
 APPROVED: [Signature] DATE 10/22/46

PER	
OP.	7
ENL.	211
P	8
S P	7
C A P	15
C P C	
MISCL.	526
NEW	4
VAC.	
TOTAL	782

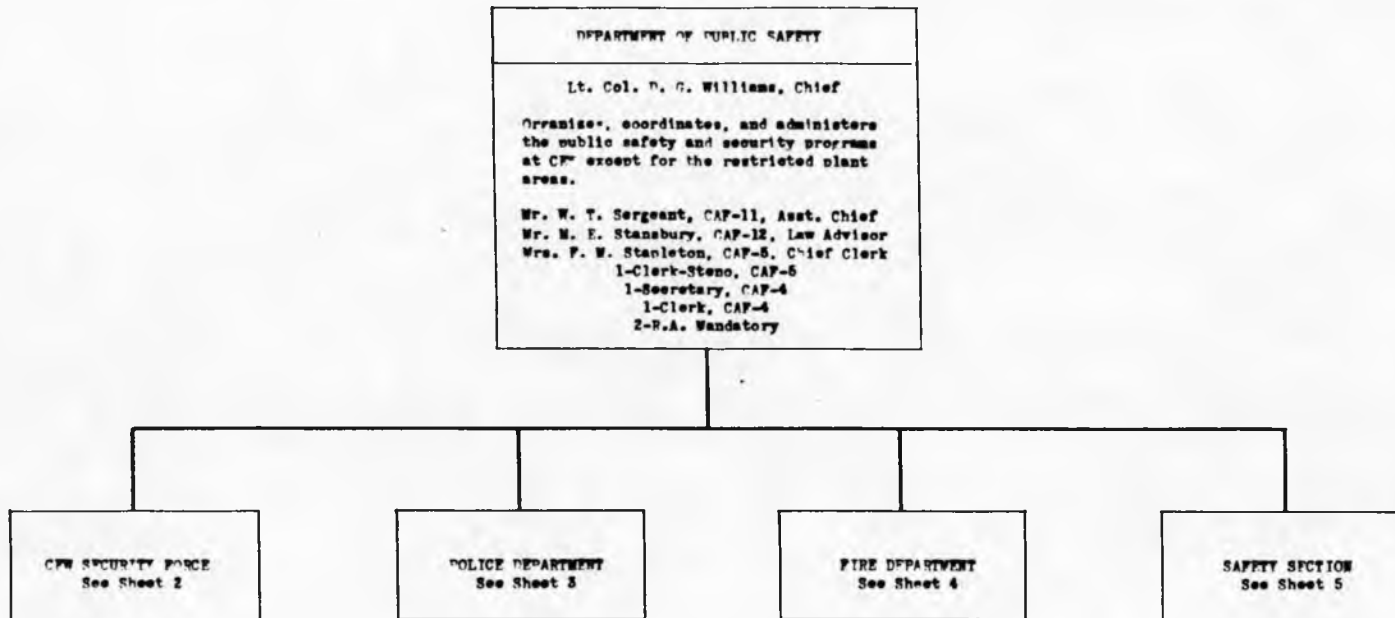

**ORGANIZATION CHART
MANHATTAN DISTRICT**

C.E.W. FACILITIES AND SERVICE DIVISION
UNIT Department of Public Safety

SUBMITTED *[Signature]* DATE 10/25/44

RECOMMENDED *[Signature]* DATE 8/10/46

APPROVED *[Signature]* DATE 7/12/44

0-24 DEPARTMENT OF PUBLIC SAFETY ORGANIZATIONAL CHART,

11 OCTOBER 1946 (5 Sheets)

PER:
 GR.....
 ENL.....
 P.....
 SP.....
 CAP..... 64
 SPC.....
 MSGL.....
 VAC..... 9
 TOTAL..... 51

COMMUNICATIONS DEPARTMENT
 MAJOR PAUL RANNEY, CHIEF.

TRAFFIC SECTION
 MRS. HILBERT L. MAGGARD, CHIEF, CAF-6
 Responsible for the operation of main switchboard and the toll and interoffice traffic of the three (3) satellite dial systems on the Area. Employs all operating personnel. Prepares payroll and maintains liaison with Bell System traffic section, in instigating better public relations and expediting the handling of traffic.
 Clerk-Typist, CAF-3 (V)

SCHEDULE AND INFORMATION SUB-SECTION
 MRS. KATHERINE E. HUSSELL, CHIEF, CAF-4
 Prepares schedules, seating plans and assigns tours of duty. Checks attendance during tours of duty. Maintains all information records, rotary files and intercept books.

GROUP SUPERVISORS
 Supervise and direct sections of main switchboard; handle all calls requiring special attention.
 Days : 2 Supv. Tel. Oprs. CAF-3
 Evening: 2 Supv. Tel. Oprs. CAF-3
 NIGHT: MRS. BESSIE DOANE, CHIEF, CAF-4
 In charge of operators and information during period of duty.

INSTRUCTION SUB-SECTION
 MISS HELEN M. LLEWELLYN, CHIEF, CAF-4
 Trains all new operators and conducts retraining courses for all operating personnel. Introduces all changes in operating practices.

DAY TOUR - 0800 to 1600
 15 Tel. Oprs., CAF-2
 3 Tel. Oprs., CAF-2 (V)
 1 Tel. Opr., CAF-1
 1 Tel. Opr., CAF-1 (V)
 5 Tel. Info. Oprs., CAF-3

EVENING TOUR - 1600 to 2400
 1 Tel. Opr., CAF-3
 7 Tel. Oprs., CAF-2
 3 Tel. Opr., CAF-2 (V)
 4 Tel. Info. Oprs., CAF-3

NIGHT TOUR - 0001 to 0800
 2 Tel. Opr., CAF-2
 1 Tel. Opr., CAF-2 (V)
 1 Tel. Info. Opr., CAF-3

ORGANIZATION CHART
 MANHATTAN DISTRICT
 CEN FACILITIES AND SERVICE DIVISION,
 UNIT COMMUNICATIONS DEPARTMENT.
 SUBMITTED BY *[Signature]* DATE 2 Oct 46
 RECOMMENDED *[Signature]* DATE 8/10/46
 APPROVED *[Signature]* DATE 10/10/46

PERSONNEL
 OFFICERS
 EML
 P
 S P
 CAF 14
 CPC
 MISCL.
 VAC. 1
 TOTAL 15

COMMUNICATIONS DEPARTMENT
 MAJOR PAUL RAMSEY, CHIEF.

COMMUNICATIONS SERVICES ACCOUNTS SECTION
 MR. GERALD L. HUTTON, CHIEF, CAF-7
 Responsible for all operating procedures and practices in initiating and maintaining adequate records of all debits and credits of the CEM Communications Services Account. Checks on delinquent accounts. Checks and audits accounting ledgers. Administers TM 24-205. Maintains liaison with public service contractors to insure a minimum of loss to Government funds.
 Miss Emer I. Dobson, Clk-Typ, CAF-1

PUBLIC RELATIONS SUB-SECTION
 MRS. HELEN E. WUTCRAFT, CHIEF, CLK, CAF-4
 Responsible for public relations in handling all complaints pertaining to toll, rental, service and incidental charges. Maintains liaison with operating and service contractors in providing billing and accounting information to promote better public relations and efficient operation in eliminating losses due to employees leaving Area without paying telephone bills in full.
 Miss Lila F. Greene, Clerk, CAF-3
 Mr. Joe Bridges, Clerk, CAF-2

BILLING SUB-SECTION
 MISS JIM A. ROBBINS, CHIEF, CAF-4
 Responsible for the segregation of toll tickets into "Commercial," "Official" and "Pay Station"; computation of taxes on "Commercial Tolls" and posting to individual customers' records. Compiling of total charges for toll, rental and taxes and rendering statements to customers at end of each billing period. Posting customer credits to record as payments are received.
 Miss Beatrice C. Eubanks, EM Opr, CAF-3
 Miss Jean C. Bird, EM Opr, CAF-3
 Miss H. R. Patterson, Clerk, CAF-3
 Miss Ruth E. Allen, Clerk, CAF-2
 Billing Machine Opr., CAF-3 (V)

ACCOUNTS RECEIVABLE SUB-SECTION
 MR. HARRY L. BRADLEY, CHIEF, CAF-6
 Responsible for collecting all Class "B" accounts, "Pay Station" receipts and delinquent accounts. Prepares collections for and makes bank deposits. Makes, on premises, an effort to collect delinquent accounts. Maintains all records of collections and disbursements according to TM 24-205.
 Mrs. Cynthia M. Greer, Cashier, CAF-3
 Miss Betty Garren, Clerk, CAF-2
 Miss Eveline Greene, Clerk, CAF-2

ORGANIZATION CHART
 MANHATTAN DISTRICT
 CEM FACILITIES AND SERVICE DIVISION,
 UNIT COMMUNICATIONS DEPARTMENT.
 SUBMITTED... DATE 2 Oct 46
 RECOMMENDED... DATE
 APPROVED... DATE

C-23

PER. OFFICERS
 COL.
 P. 1
 SP.
 CAP. 12
 SPO.
 MISCL.
 VAC. 2
 TOTAL 15

COMMUNICATIONS DEPARTMENT
 MAJOR PAUL RANSKY, CHIEF.

RECORDS SECTION
 CAPTAIN G. L. AGNOR, CHIEF *

Responsible for posting and filing of line record cards; completion of telephone work orders and requests; preparation of telephone work orders, accounting information, directory information and office bulletins. Maintains liaison with telephone company field representatives in expediting telephone work orders and maintaining directory listings.

Mrs. Annora Parsons, Clerk, CAF-4
 Miss Maud N. Phelps, Clerk, CAF-3
 Mrs. Addie B. Carpenter, Clk-Steno, CAF-3
 Mrs. Jennita C. Baker, Clerk, CAF-2
 Miss Ruth W. Jackson, Clerk, CAF-2

SERVICE AND CONTROL SECTION
 CAPTAIN G. L. AGNOR, CHIEF *

Maintains liaison with all contractors in providing efficient and economical communication service necessary for plant or contract operation. Controls all telephone installations, disconnects, moves and equipment service for all types of customers. Controls receipts and expenditures of CEN Communications Services Account funds and Government funds for communications services.

Miss Maud C. Miller, Clerk, CAF-6
 Mr. Arnold A. Toney, Clerk, CAF-5

ENGINEERING AND CONSTRUCTION SECTION
 MR. JAMES D. McPHERSON, CHIEF, P-4

Maintains liaison with construction officers and contractors with regard to providing additional facilities. Keeps engineering records of outside plant facilities in order to make economical use of existing equipment and to plan for future expansion. Checks all proposed construction to determine military necessity. Inspects completed construction to determine adequacy and compliance with policy. Inspects each month telephone installations in accordance with TM 24-205.

Mrs. Vera A. Hope, Clk-Typ, CAF-3

TELETYPE, TELEGRAPH AND CRYPTOGRAPH SECTION
 MR. W. C. EVANS, CHIEF, CAF-5

Responsible for receiving and transmitting TT over commercial and ACAN; receiving and transmitting telegrams; enciphering classified messages; all files and records pertaining to TT and Teleg. operation and traffic, cryptographic operation and accounting for cryptographic materials.

Miss Georgia B. Jones TT Oper., CAF-3
 Miss Charlotte J. Foster, TT Oper., CAF-3
 Mr. W. E. Craven, Crypto. & TT Oper., CAF-3
 TT Operator, CAF-4 (V)
 TT Operator, CAF-3 (V)

ORGANIZATION CHART
 MANHATTAN DISTRICT
 CEN FACILITIES AND SERVICE DIVISION,
 COMMUNICATIONS DEPARTMENT.

UNIT
 SUBMITTED *PH* DATE 2 Oct 46
 RECOMMENDED *John E. ...* DATE 10-10-46
 APPROVED *John E. ...* DATE 10-10-46

C-23