

THIS FILE IS MADE AVAILABLE THROUGH THE DECLASSIFICATION EFFORTS AND RESEARCH OF:

THE BLACK VAULT

THE BLACK VAULT IS THE LARGEST ONLINE FREEDOM OF INFORMATION ACT / GOVERNMENT RECORD CLEARING HOUSE IN THE WORLD. THE RESEARCH EFFORTS HERE ARE RESPONSIBLE FOR THE DECLASSIFICATION OF THOUSANDS OF DOCUMENTS THROUGHOUT THE U.S. GOVERNMENT, AND ALL CAN BE DOWNLOADED BY VISITING:

[HTTP://WWW.BLACKVAULT.COM](http://www.blackvault.com)

YOU ARE ENCOURAGED TO FORWARD THIS DOCUMENT TO YOUR FRIENDS, BUT PLEASE KEEP THIS IDENTIFYING IMAGE AT THE TOP OF THE .PDF SO OTHERS CAN DOWNLOAD MORE!

247
248
PAGE
2 4 A

~~SECRET~~

CLASSIFICATION CANCELLED
BY AL [unclear] OF [unclear]
JOHN K. [unclear]
REVIEWED BY [unclear] 9/6/79

MANHATTAN DISTRICT HISTORY
BOOK V - ELECTROMAGNETIC PROJECT
VOLUME 5 - CONSTRUCTION

~~RESTRICTED DATA~~
Atomic Energy Act 1946
Special Restricted Data
Clearance Required

~~SECRET~~

[REDACTED]

FOREWORD

The construction of the Electromagnetic Plant in Tennessee was a very important phase of the Manhattan District's Electromagnetic Project. The history of that construction, from the beginning to 1 January 1947, is contained in this volume. In addition to the Summary and main Text the volume contains appended documents, references, charts and a chronologically arranged set of photographs showing the construction progress.

"Construction" is Volume 5 of the book describing the Electromagnetic Project. The titles of the other volumes are as shown below:

Volume 1 - General Features

Volume 2 - Research

Volume 3 - Design

Volume 4 - Silver Program

Volume 5 - Operation

~~RESTRICTED~~
Atomic Energy Act 1946
Special Restricted Data
Access Required

1 August 1947

[REDACTED]

SECRET

MANHATTAN DISTRICT HISTORY
BOOK V - ELECTROMAGNETIC PROJECT

VOLUME 5 - CONSTRUCTION

TABLE OF CONTENTS

<u>Par. No.</u>		<u>Page No.</u>
	FOREWORD	
	SUMMARY	
	SECTION I - GENERAL	
1-1	Purpose	1.1
1-2	Scope	1.1
1-3	Authorisation	1.1
1-4	Administration	1.2
1-5	General Description	1.2
1-6	Relationship With The Clinton Engineer Works	1.3
	SECTION 2 - CONTRACTUAL ARRANGEMENTS	
2-1	Selection of A-E-M Contractor	2.1
2-2	Stone and Webster Engineering Corporation Contracts	2.1
	a. Contract No. W-7401-eng-13	2.1
	b. Contract No. W-14-108-eng-19	2.3
	c. Contract No. W-14-108-eng-60	2.4
2-3	Government Contracts	2.4
2-4	Stone & Webster Subcontracts	2.4
2-5	Cost of Electromagnetic Plant	2.5
	a. Total Plant Cost	2.5
	b. Cost of Construction	2.6
	SECTION 3 - CONSTRUCTION PROGRAM	
3-1	Mobilisation	3.1
	a. General	3.1
	b. Specialty Crews	3.1
	c. Special Tools	3.2
	d. Project Shops	3.2
3-2	Building Schedules	3.3
	a. General	3.3
	b. Development Plant	3.3
	c. The Alpha I Buildings	3.3
	d. The Beta Buildings	3.4
	e. Alpha II Buildings	3.4
	f. New Beta Buildings	3.4

SECRET

	g. Other Plant Schedules	3.4
3-3	Initial Construction	3.5
3-4	Foundation Problems	3.5
	a. The Third Alpha Building	3.5
	b. Other Buildings	3.6
3-5	The Development Plant	3.7
	a. Construction	3.7
	b. Construction Changes	3.8
3-6	The Alpha I Plant	3.8
	a. The First Alpha Building	3.8
	b. Initial Operation	3.10
	c. Rebuilding of the First Track	3.11
	d. The "Walking" Tanks	3.11
3-7	The Original Beta Process Building	3.12
3-8	Original Chemistry Buildings	3.13
3-9	Administration and Service Buildings-	3.15
	a. Frame Construction Group	3.15
	b. Masonry Construction Group	3.16
	c. Completion Statistics	3.16
3-10	Y-12 Extension	3.16
3-11	New Alpha Construction	3.17
	a. General	3.17
	b. Construction	3.18
	c. Alterations	3.19
	d. Completion	3.19
3-12	The Second Beta Process Building	3.20
3-13	Chemical Facilities With the Extension	3.21
3-14	Construction of the 9207 Group	3.21
3-15	The Third Beta Process Building	3.22
3-16	The Fourth Beta Process Building	3.23
3-17	Construction Status 1 July 1945	3.23
3-18	Utilities	3.23
	a. General	3.23
	b. Water Supply System	3.24
	c. Sewage Disposal	3.24
	d. Electric Power	3.25
	e. Steam Plant	3.26
3-19	Roads	3.27
3-20	Railroads	3.27
3-21	Fences and Guard Towers	3.28
	a. Perimeter Fence	3.28
	b. Interior and Temporary Fences	3.28
	c. Guard Towers	3.29
3-22	Work Performed Under Service Contract	3.29
	a. General	3.29
	b. Scope	3.30
	c. Major Construction	3.31
	d. Review	3.33

3-23	Temporary Facilities	3.33
	a. General	3.33
	b. Warehouses	3.34
	c. Shops	3.34
	(1) Machine Shop	3.34
	(2) Pipe Shops	3.34
	(3) Carpenter Shops	3.35
	(4) Miscellaneous Shops	3.35
	d. Office Buildings	3.35
	e. Miscellaneous Temporary Facilities	3.36
	(1) Canteens	3.36
	(2) Clock Alleys	3.36
	(3) Stone Crushing and Concrete Mixing Plants	3.36
	f. Equipment	3.37
	g. Temporary Roads	3.37
	h. Facilities for Night Work	3.37

SECTION 4 - MATERIALS OF CONSTRUCTION

4-1	Procurement	4.1
4-2	Expediting	4.1
4-3	Receipt and Distribution	4.3
4-4	Disposal of Scrap	4.4
4-5	Construction Statistics	4.4
	a. General	4.4
	b. Peak Carload Receipts	4.5
	c. Total Car Receipts of Certain Material	4.6
	d. Representative Quantities for Y-12 Area	4.6

SECTION 5 - LABOR RELATIONS, SAFETY AND SECURITY

5-1	Labor Recruitment and Industrial Relations	5.1
	a. Procurement of Labor	5.1
	(1) Local Offices	5.1
	(2) Distant Sources of Labor	5.1
	(3) Magnitude of the Labor Problem	5.2
	b. Housing	5.3
	c. Transportation	5.3
	d. Recreation and Welfare	5.4
	e. Labor Relations and Stoppages	5.5
5-2	Safety	5.5
	a. General	5.5
	b. Obligations of the Safety Department	5.6
	(1) Accident Reporting	5.6
	(2) Orientation of New Employees	5.6
	(3) Sanitation and Public Health	5.7
	(4) Fire Prevention Inspection	5.7
	(5) Sterilization of Personal Protective Equipment	5.7

Par. No.

Page No.

	(6) Motor Vehicle Inspection	5.7
	c. Policies of the Department	5.7
	(1) Cooperation with Other Agencies	5.7
	(2) Meetings	5.7
	(3) Publicity and Education	5.8
	d. Medical Facilities	5.8
	e. Comparative Statistics	5.8
	f. Fatal Accidents	5.9
5-3	Security	5.9
	a. Guard Force	5.9
	b. Fire	5.10
	(1) General	5.10
	(2) Water Mains	5.10
	(3) Procedures	5.11
	(4) Hazards from Welding	5.11
	(5) Material Storage Practice	5.11
	(6) Damage by Fire	5.12
	(7) Firemen-trainees	5.12
	c. Intelligence and Security	5.12
	(1) Clearance for Restricted Area	5.12
	(2) Fingerprints	5.13
	(3) Badges and Passes	5.13
	(4) Personnel Investigation	5.14

SECTION 6 - ORGANIZATION AND PERSONNEL

6-1	Manhattan District	6.1
6-2	Stone and Webster Engineering Corporation	6.2
6-3	Acknowledgements of Assistance	6.4
	a. Magnet Coil Construction	6.5
	b. Distilled Water System	6.5
	c. Installation Procedures	6.5

APPENDIX "A" - DOCUMENTS

APPENDIX "B" - REFERENCES

APPENDIX "C" - PHOTOGRAPHS

APPENDIX "D" - MAPS AND CHARTS

INDEX



SUMMARY

1. General. - In 1942, the President of the United States, acting under authority of the War Powers Act, authorized the construction of the Electromagnetic Plant. The purpose of this construction program was to erect, in the shortest possible time, the buildings and auxiliary facilities and to install the equipment necessary for the electromagnetic method of separating the uranium isotope 235. The scope of the program embodied the task of interpreting the design drawings and transforming them into a full-scale plant for quantity production. The plant consists of process buildings for the actual separation of uranium isotopes; chemical facilities for the preparation and recovery of feed material; auxiliary facilities necessary for plant operation; utilities for the proper functioning of the plant; and administrative and service facilities for the needs and welfare of the operating personnel. The Electromagnetic Plant is one of four industrial plants at the Clinton Engineer Works, near Knoxville, Tennessee, and is located in a restricted area of about 825 acres in the central part of the reservation.

2. Contractual Arrangements. - A thorough review of architect-engineer-construction firms resulted in the selection of Stone and Webster Engineering Corporation to represent the Manhattan District in the design, procurement of materials, and construction of the electromagnetic plant. Stone and Webster's responsibility, under Contract No. W-7401-eng-13, dated 29 June 1942, was to include the entire ESM Project as conceived at that time. When this responsibility expanded beyond the capabilities of one concern, Stone and Webster retained the construction



of the Electromagnetic Plant, plus the Central Facilities, which included the town of Oak Ridge. This contract was supplemented five times, to include the major portion of all work at Y-12. Supplement No. 2, which was for the Y-12 Extension, was the largest of the Supplemental Agreements. This contract was closed out on 31 March 1945.

On 17 November 1944, Stone and Webster was awarded Contract No. W-14-108-eng-49, for such additional construction work and major alterations as were required from time to time. A specific stipulation of this contract was that no single item of work was to exceed \$6,000,000, so when the fourth Beta Building was authorized, a new contract, No. W-14-108-eng-60, was negotiated with Stone and Webster for this work, effective 2 April 1945.

All government prime contracts, which, in general, were confined to materials and equipment where the amounts exceeded \$100,000, were supervised by Stone and Webster. Stone and Webster also awarded sub-contracts to contractors who were specialists in their line of work.

The original estimated cost of the Y-12 Plant was \$56,500,000 out of a total of 66 million dollars allocated for the DSM Project. This amount was augmented by costs for the Y-12 Extension and other additions till, on 1 July 1945, the estimated construction cost for the electromagnetic plant under Contract No. W-7401-eng-13 was \$259,200,000. Contracts numbers W-14-108-eng-49 and W-14-108-eng-60 increased this amount by \$14,047,500 and \$18,164,000 respectively. ~~Thus~~, The estimated cost of the electromagnetic plant, as of 1 July ^{January 1947} ~~1945~~, was \$301,411,500.

100

of which \$144,944,100¹⁰⁰ was the construction cost and \$136,447,400⁵⁰⁰ the cost of equipment. These amounts are increased to a total of ~~\$309,356,700~~ ^{312,378,700} by the addition of the cost for design, fees, and the silver program.

3. Construction Program. - The construction of a plant of this magnitude required an extremely well organized and coordinated field force. Stone and Webster gathered its experienced key personnel, and augmented them with other experienced construction men, to form the nucleus of their organization. Speciality crews were trained to perform the many operations which were repeated in the various buildings. Special jigs were developed to facilitate certain of these operations. In many cases, shops were constructed to manufacture, or assemble, much of the equipment that could not be furnished elsewhere, in time to meet the rigid building schedules. These schedules were set to coordinate with the operating sequence. In this respect, the Alpha buildings were scheduled first, but throughout construction, priorities were placed on certain phases, to suit design changes or new authorizations. The plant originally was to consist of three Alpha and one Beta process buildings, a chemistry building for Alpha and one for Beta, development buildings, utilities and numerous service and auxiliary facilities.

Excavation for the foundation of Alpha Building 9201-1 was started on 18 February 1943, and succeeding buildings followed with little difficulty, until excavation for the Third Alpha Building disclosed numerous large, flat and irregularly spaced boulders. As building locations were definitely established, this difficulty was overcome by stripping the area,

[REDACTED]

digging the clay and shattered rock out of the crevices, flushing this area thoroughly with fire hose, and laying a concrete mat over boulders, thus tying them together and forming a secure foundation.

Construction of the Alpha buildings, which were reinforced concrete structures with brick walls, then proceeded according to schedule and the buildings were soon ready for the installation of equipment. During this stage of activities, thousands of tons of materials and equipment poured into the area. When the first racetrack in Building 9201-1 was ready for preliminary operation on 1 November 1943, it was found that the magnet coils showed a very low resistance to ground. The failure, caused by contaminants in the oil lines, required that the coils be returned to the manufacturer and rewound. Precautions were taken to eliminate this failure on future installations.

The Beta Process Building (9204-1) was started on 15 May 1943, and the installation work for this building followed more exacting procedures than in the Alpha group, as a more valuable material was to be used as feed. The first racetrack was ready for operation on 13 March 1944, but the building was not called complete until September 1944.

The construction of the Alpha (9202) and Beta (9203) Chemistry Buildings was started in February of 1943, to keep pace with the construction of the process buildings. The buildings, as originally designed, were completed in September 1943, but continual changes were made because of new procedures developed from operational experience. The Beta (9203) Building was later converted into a laboratory when a larger building (9206) was constructed for Beta Chemistry.

[REDACTED]

Many auxiliary and service buildings were necessary for plant operation. Most of these structures were of frame construction, but several, because of the nature of the building or because of fire or other hazards, were of masonry construction. Among these were the Medical Building, Dry Ice Storage, Liquid Nitrogen Storage, Foundry, and the Electrical Maintenance Shop.

In September 1943, General Groves authorized the construction of an addition to the Y-12 plant which more than doubled its size. This addition, known as Y-12 Extension, included two new Alpha Process Buildings (9201-4 and 5), a Beta Process Building (9204-2), an addition to Alpha Chemistry Building (9202), a new Beta Chemistry Building (9206), and numerous auxiliary buildings.

The Alpha II Process Buildings, the first of which was started on 2 November 1943, are the largest buildings in the Y-12 Plant, measuring 543 feet by 312 feet and standing some 90 feet from the valley floor. They are of steel frame construction with corrugated asbestos siding. Equipment installation was started even before steel framing was complete. The change in design for the racetracks, from an oval shape to a rectangular arrangement, made this installation much simpler, and eight months after the first building was started, it was ready for operation.

The construction of the second Beta Process Building was started 20 October 1943. The installation of equipment began on 1 April 1944, and the first track was ready for operation on 10 September 1944. A third Beta Process Building was authorized in May 1944, to handle the increased Alpha production expected because of enriched feed from the Gas Diffusion Plant.

[REDACTED]

This new building (9204-3) was similar in arrangement to the two earlier buildings but was of steel frame construction instead of reinforced concrete. Building completion was achieved 15 May 1945, after numerous changes to the chemical area. A fourth Beta Process Building (9204-4) was authorized 2 April 1945, to handle increased production resulting from Gas Diffusion Plant feed. This building was completed by 1 December 1945.

Included in the authorization of the Y-12 Extension was the addition to Alpha Chemistry Building (9202) and the construction of Beta Chemistry Building (9206). In June 1944, an entirely new group of Alpha chemistry buildings was necessary, to provide for the large quantities of enriched feed material to be obtained from the Gas Diffusion Plant. This group of buildings, known as the 9207 Group, consisted of a six-story process chemical building, a chemical storage building, change houses, pump houses and tank farms. These were supplemented by an incinerator building, a vacuum distillation building, a compressor building, a hydrolysis tower and an ammonia storage building. Construction was stopped in June 1945, because increased enrichment of Gas Diffusion Plant product made it desirable to feed this material directly to the Beta stage, thus ultimately eliminating the Alpha stage entirely.

Most of the utilities for the Y-12 plant were constructed and operated in conjunction with the Central Facilities for the Town of Oak Ridge. As the plant is the largest consumer of water and electricity these utilities are located closer to the plant than to the town. Sewage from the plant

~~SECRET~~

drains by gravity through an interceptor sewer to the Oak Ridge ^{sewer} sewage system. The two steam plants, constructed within the Y-12 Area, distribute process steam and steam for heating the buildings, through insulated steam pipes supported on wooden pole structures.

Operational activities during the latter part of 1944, indicated the necessity for extensive changes in process and equipment. As Tennessee Eastman Corporation was burdened with the usual operational difficulties and maintenance problems, Stone and Webster, which was nearing completion of its original contract, was given a new contract (W-14-108-eng-49) for this work. Of the numerous additions and revisions performed under this contract, the largest single project was for the Final Product Building (9212). The building was authorized for construction on 5 April 1945, and by 1 July 1945, the design was complete and the structure was 36% complete.

The construction of the Y-12 Plant was facilitated by the use of numerous temporary buildings. Warehouses, shops, office buildings, change houses, time offices, etc., were built for specific purposes and, when no longer needed by the construction forces, many of them were turned over to Tennessee Eastman Corporation to facilitate the operation of the plant. Access facilities to the Electromagnetic Plant were provided by bituminous surfaced roads and a spur track from the L&N Railroad. Accessibility was restricted by an 8-foot cyclone fence which surrounded the area. Gates, guard towers and interior fencing were constructed to facilitate further the guarding of this highly restricted area.

[REDACTED]

4. Materials of Construction. - Because of the size and diversification of the Electromagnetic Plant, it was deemed necessary to establish two distinct Purchasing Departments, one of which, in the Boston office of Stone and Webster Engineering Corporation, was primarily concerned with the procurement of process equipment; the other, with headquarters at Oak Ridge, Tennessee, dealt with structural materials and associated items. The nature of the project involved the procurement of vast quantities of materials already in the critical category, such as steel, copper, alloy pipe, etc. With the aid of the War Production Board and efficient expediting, these enormous quantities of materials were transformed into vital facilities necessary for the successful operation of the electromagnetic plant. The receiving, warehousing and distribution of material for construction involved one of the most intricate problems of management. From a somewhat primitive beginning, when equipment was dumped alongside the road, the scope of the work grew to include warehouses for special types of equipment and numerous general warehouses located at various points all over the area. Process equipment of a highly secret nature was stored in a specially provided area, under armed guard, and was unpacked only at the site destined for its ultimate installation.

The facts that 31 carloads of brick were received in one week and 128 carloads of electrical equipment were received in a two-week period, are significant indications of the stupendous task that confronted the contractors.

5. Labor Relations, Safety and Security. - Procurement of personnel

[REDACTED]

SECRET

for the construction of the Electromagnetic Plant was a tremendous job. After scraping the bottom of the local employment services, it was necessary to establish a recruiting service and gather workers from distant sources in order to finish the work according to schedule. It was estimated that some 400,000 persons were interviewed for the entire Stone and Webster program; this is approximately equivalent to interviewing the entire population of Houston, Texas. In spite of the fact that inductions into the Army were at their height and that premium wages were being paid on other government jobs, adequate labor was found to do the work, as inducements in the form of transportation, recreational facilities, etc., were provided. In any undertaking of this magnitude, in which thousands of skilled and unskilled workers are thrown together, it is reasonable to expect some labor difficulties and grievances. However, because of diplomatic arbitration, less than 8,000 manhours were lost on account of jurisdictional disputes and work stoppages, as compared with a total of 66,767,000 manhours worked on the Electromagnetic Plant.

Another commendable job was that of the Safety Department, who, through diligent effort, set an enviable record for safety. The more important duties of this department included accident reporting, orientation of new employees, sanitation and public health, fire prevention inspection, sterilization of personnel^{a/} protection equipment, and motor vehicle inspection. It was the policy of the department to cooperate with the other safety organizations, to hold weekly meetings to discuss current safety problems, and to educate the workers through the medium of safety posters.

SECRET

~~SECRET~~

Through the Military Intelligence, every effort was made to impress the workers with the need for secrecy. The work was so segmented that very few individuals knew the over-all scope of the work. In order to protect the plant from sabotage, accidents, fires, and other hazards, strict security regulations were put in force. All personnel were investigated before being hired, and had to provide the proper credentials to enter restricted areas. Guards were strategically stationed to assure conformance with security regulations. Fire preventive measures, such as, proper spacing of water hydrants and extinguishers, adequate alarm systems, orderly arrangement of stored materials, proper training of fireman, etc., were instrumental in preventing serious losses by fire.

6. Organization and Personnel. - Construction at the Electromagnetic Plant, performed under Stone and Webster Engineering Corporation management, ^{was} supervised for the Manhattan District by the Y-12 Construction Officer, who ^{was} responsible, through the Y-12 Unit Chief, to the District Engineer, Col. K. D. Nichols. Prior to January 1945, the construction officer was directly responsible to the District Engineer, and the Y-12 Unit Chief assisted the District Engineer in coordinating the design and operation phases of the program with construction. The operating contractor, Tennessee Eastman Corporation, assisted in the final inspection and recommended that the facilities be accepted as they were completed for operation by the Government.

The Stone and Webster activities in the development and construction of the Y-12 Plant were under the direct management of Mr. R. F. Branch,

[REDACTED]

President. The Project Engineer was Mr. A. C. Klein and the Project Managers were Mr. T. C. Williams and Mr. I. R. Thornburg.

[REDACTED]

[REDACTED]

MANHATTAN DISTRICT HISTORY
BOOK V-ELECTROMAGNETIC PROJECT
VOLUME 5-CONSTRUCTION
SECTION 1 -GENERAL

1-1. Purpose. - The electromagnetic process, as evolved from small scale laboratory developments by the research organization, had to be expanded directly by the design engineers into an industrial plant of high proportions, housing a tremendous amount of highly specialized electrical and mechanical equipment for quantity production of the uranium isotope 235. The purpose of the construction program was to construct the buildings and auxiliary facilities and to install the equipment necessary for this plant in the shortest possible time.

1-2. Scope. - The scope of the construction program embodied the task of interpreting the design drawings and transforming them into a "ready to operate" full scale plant, located in an isolated part of Bear Creek Valley in the Clinton Engineer Works. The enterprise included the mobilisation and direction of enormous labor forces and the procurement and erection of material and equipment for the process plant and its auxiliary facilities. This construction consisted of more than two hundred buildings and represented an expenditure of more than three hundred million dollars (See App. D1). The program had to be accomplished in an incredibly short time despite the obstacles of isolation, shortage of material and labor, design changes and the ever present need for secrecy.

1-3. Authorization. - The construction of the electromagnetic (Y-12) plant was authorized by the President of the United States, under authority

[REDACTED]

conferred upon him by Congress through the Public Laws known as the War Powers Acts. As described in Volume 1, the President's approval of the 13 June 1942 report, submitted to him by Dr. James B. Conant, Chairman of the National Defense Research Council, and Dr. V. Bush, Director of the Office of Scientific Research and Development, constituted a directive to the War Department. As the representative of the War Department, the Manhattan District was responsible for carrying out the requirements of the directive. A specific requirement was the construction of an Electro-magnetic Separation Plant (See Vol. 1-General Features).

1-4. Administration. - In administering the construction program, the District Engineer, through the Y-12 Construction Officer, supervised the construction work performed by the Architect-Engineer-Construction-Management contractor, Stone & Webster Engineering Corporation. Stone & Webster performed the major part of the construction with its own forces and supervised the efforts of its subcontractors. Tennessee Eastman Corporation, the plant operating contractor, assisted in final inspection and recommended that the facilities be accepted by the Government as they were completed for operation.

1-5. General Description. - The Electromagnetic Plant consists of nine process buildings, having a combined floor area of about 2,300,000 sq. ft. (about 53 acres), with numerous auxiliary, chemistry, service, and administration buildings, having a combined floor area of about 1,150,000 sq. ft. Facilities in these buildings not only service the plant but also provide for the needs and welfare of over 20,000 operating and administrative personnel. Two boiler plants provide central heating for

[REDACTED]

all the buildings and steam for the manufacturing process, the steam being distributed through overhead mains. Electric service is obtained through a high tension network connected with the Tennessee Valley Authority power lines at two main switching stations in the area. Water service is obtained from the Central Facilities, treated water by gravity flow from the Filtration Plant and raw water by direct pumping from the Clinch River. Railroad sidings were constructed connecting each of the process buildings with the classification and storage yards, which, in turn, were connected by means of a spur with the Louisville & Nashville Railroad (See Central Facilities, Book 1, Vol. 12). The Bear Creek Valley Road was relocated to form the north boundary of the manufacturing area and is the main access road connecting to Scarboro Road and thence the road system of the entire project. There are three portals, located along this road, through which automotive equipment and personnel are properly cleared before entering or leaving the area. The entire Electro-magnetic Plant site is surrounded by a manproof wire fence, with interior restricted buildings further isolated by fencing. A general plan of the plant is shown as Appendix D12. Photographs which give an indication of the immensity of the job are included as Appendices C33, C35, C36, C37 and C39.

1-6. Relationship With The Clinton Engineer Works. - The Electro-magnetic Plant, more commonly known as Y-12, is one of four industrial plants located in the Clinton Engineer Works near Knoxville, Tennessee. It is located in a restricted area of about 825 acres in the central southeastern part of the reservation, approximately five miles southwest of



the commercial district of Oak Ridge, Tennessee, which is the townsite and housing project in connection with the overall development (See Location Map App. D13). Housing for eligible workers is available in this town, and the plant is furnished services such as power, water, sewage disposal, transportation, railroad freight and other essentials by the Clinton Engineer Works Central Facilities (Book 1, Vol. 12). The Electromagnetic Plant is the largest industrial plant in the Clinton Engineer Works from the standpoint of employment, was the first production plant on which construction was started, and was the first to go into operation. Until 5 December 1946, it was the only plant producing the final product. The Gas Diffusion Plant (K-25) and the Thermal Diffusion Plant (S-50) acted as feeders to the Electromagnetic Plant until September 1945; from this date until the present time, 1 January 1947, feed material has been supplied entirely by the Gas Diffusion Plant.

[REDACTED]

SECTION 2 - CONTRACTUAL ARRANGEMENTS

2-1. Selection of A-E-M Contractor. - The early plans for execution of the Manhattan District Project, formulated in June 1942, called for the engagement of a large contracting firm to represent the District in the field of design, procurement of materials and construction of facilities for the overall project. A thorough review of the Architect-Engineer-Construction firms resulted in the selection of the Stone and Webster Engineering Corporation for this important function because they were considered to be the best qualified of the available firms, on the basis of organizational size, availability, experience and previous connection with the uranium project. Stone and Webster's responsibility included the entire DSM Project as conceived at that time. Subsequently, the scope of its responsibility was reduced because the scope of the District program expanded beyond the capabilities of any one concern. However, the construction of the Y-12 Project was retained as the primary responsibility of Stone and Webster (for further details, see Book I, Volume 1, and Book V, Volume 3).

2-2. Stone & Webster Engineering Corporation Contracts.

a. Contract No. W-7101-eng-13. - Following preliminary negotiations, which were necessarily limited because of the urgency of the work, Stone & Webster Engineering Corporation was given a letter contract dated 29 June 1942. Subsequently, the formal cost-plus-a-fixed fee contract No. W-7101-eng-13 was entered into, effective as of the same date. This included Architect-Engineer-Management service to do

[REDACTED]

all things necessary for the following purposes: the completion of the required research, design, procurement, inspection and expediting of materials and equipment for certain plants; the initial procurement of essential raw materials; the operation of such plants; and the construction of the plants and other facilities. One of these plants was the Electromagnetic Plant. The major part of the construction of the Y-12 Area was performed directly by the contractor. The remaining portions were completed through subcontracts or government contracts, which were managed and supervised by Stone and Webster (See Par. 2-3 and 2-4). Five supplemental agreements modified the contract as the scope or conditions of the work changed with the development of the project.

Supplemental Agreement No. 1 deleted certain items of work and confined Stone & Webster's responsibility to the electromagnetic plant, the expansion and modification of ^{an} existing auxiliary manufacturing plant (Trail, B.C.), a pilot plant (Clinton Engineer Works, Elza, Tenn.), an experimental plant (Argonne Forest, Chicago, Ill.), a laboratory (University of Chicago) and the town of Oak Ridge, the scope of which had been materially increased.

Supplemental Agreement No. 2 provided for the extension to the original plant and the consequent increase in town facilities.

Supplemental Agreement No. 3 authorized the disposition of certain Government-owned property.

Supplemental Agreement No. 4 provided for changes in the scope of the work, which included the addition of new facilities and the conver-

[REDACTED]

sion of existing facilities, as the result of enhanced feed from the Gas Diffusion Plant.

Supplemental Agreement No. 5 authorized payment of a portion of the fee retained, in an amount not to exceed 50%.

The contract was finally closed out 31 March 1945, except for the administrative work necessary to complete the records. All uncompleted construction work was completed under another contract (See Contract No. W-14-108-eng-19). The total construction cost for the Y-12 Plant under this contract was \$269,200,000 (See App. B4).

b. Contract No. W-14-108-eng-19. - On 17 November 1944, the operator (Tennessee Eastman Corporation) requested that the Government make provision for the establishment of an organization to do such additional construction work and to make all major building and equipment alterations as would be required from time to time, by reason of new discoveries in the development of the electromagnetic method of separation, and to provide and operate a project machine shop (See App. B5). It was also recommended that a contract be entered into with Stone & Webster Engineering Corporation for that purpose. The District Engineer agreed with these recommendations and, accordingly, a contract was negotiated with Stone and Webster. That contract provided that any item of work (i.e. erection of a new building or any single major alteration), involving a cost in excess of six million dollars (\$6,000,000) was not deemed to fall within the scope of the work. It also provided that the contractor organize, operate and maintain a machine shop at the Clinton Engineer Works and perform such work therein as the Contracting Officer might direct. The contract further stipulated that certain work not

[REDACTED]

completed on Contract No. W-7401-eng-13 as of March 31, 1945, was to be transferred to this contract. The specific term of the contract was from 2 February 1945 to 2 August 1945 and provision was made for a six months time extension to be exercised at the option of the Contracting Officer (See also Par. 3-23).

c. Contract No. W-14-108-eng-60. - Upon the decision to add a Fourth Beta (second stage) Process Building to the plant, a new cost-plus-a-fixed fee Architect-Engineer-Management Contract was negotiated with the Stone & Webster Engineering Corporation, effective 2 April 1945, to construct this building (See App. B6). As of 1 July 1945, work was well underway on this job.

2-3. Government Contracts. - The three contracts entered into with Stone and Webster Engineering Corporation as A-E-M provided that they should perform all construction work with their own forces, except in cases where, in their opinion, the completion of the facilities would be expedited, or a savings in cost to the Government could be effected by other procedure. Under these circumstances, subcontracts were either negotiated through Stone and Webster, or prime contracts were initiated directly by the Government. The government contracts were, in general, confined to materials and equipment where the amount exceeded one hundred thousand dollars. Sixty-five such contracts were negotiated with 29 different vendors in the total amount in round figures of \$106,000,000 (See App. B15). Twenty-two of these contracts were for construction work totaling in round figures \$8,400,000 (See App. D2 and D3).

2-4. Stone & Webster Subcontracts. - In view of the provision,

[REDACTED]

described in Par. 2-3, subcontracts let by Stone and Webster for certain types of work were awarded to contractors who were specialists in their line of construction work. This procedure provided for quality of workmanship and economical and expeditious performance. All such contractual arrangements were carried on with the written approval of the Contracting Officer. Two subcontracts for major items of work were negotiated under a fixed-fee arrangement. The electrical installation work was subcontracted to Watson-Flagg Engineering Corporation under Contract No. 43-F-6228 in the amount of \$11,988,685.00 which includes a fee of \$454,500.00. Similarly, a contract was negotiated with Hanley & Company for the piping installation work. This subcontract No. 83-F-9820, in the amount of \$7,417,858.00 included a fee of \$275,000.00. New fixed-fee contracts with these two subcontractors were negotiated for work on the Fourth Beta Building in the amounts of \$733,513.44 and \$672,850.00 respectively. There were 68 subcontracts in connection with the construction of the Y-12 Plant, 62 under the major contract (No. W-7401-eng-13) and 3 each under the two succeeding contracts. A complete list of the subcontracts and orders for the Y-12 Project, including Y-12 Extension, is shown as Appendix D4 and D5.

2-5. Cost of Electromagnetic Plant

a. Total Plant Cost. - In June 1942, when the original Stone and Webster contract (W-7401-eng-12¹³) was entered into, the total estimated cost for the entire scope of the DSM Project was \$66,000,000, of which \$36,500,000 was allocated to the Y-12 Plant, with the balance for Engineering, Townsite, Administration and Central Facilities, Raw

[REDACTED]

Materials and Off-area Projects (See app. B1). A year later, those plans were more completely developed, and as a result the estimated cost was revised to \$101,532,000 (See App. B2). Between this date and 1 July 1945, the plant was again increased by the addition of Y-12 Extension, and by further additions, to provide for the enhanced feed from adjacent plants. This brought the estimated cost for Y-12 under this contract to \$269,200,000. The Service contract (W-14-103-eng-49) for the required changes and additions found necessary from occupational and experimental experience, and the construction contract (W-14-103-eng-60) for the fourth Beta Building, increased this cost by \$14,047,600 and \$18,134,000 respectively. The estimated cost of building and equipping the Electromagnetic Plant, as of 1 January 1947 amounted to \$301,411,000. (See Appendix D1). In addition, design cost of \$5,619,300, fees amounting to \$3,334,679, and the cost of the Silver Program amounting to \$2,482,626, bring the total plant cost up to \$312,393,705.

b. Cost of Construction. - Of the estimated \$312,393,705, which represents the total cost for the completion of the Electromagnetic Plant, \$184,964,102 is the estimated cost for construction work performed, exclusive of the cost of design, equipment, fees and the Silver Program. Of this amount \$113,239,523 is for construction work performed by Stone and Webster's own forces and the remaining \$46,724,579 is for construction contracts, subcontracts, and orders under Stone and Webster supervision (See App. D2). As of 1 July 1945, the project was 92.1% complete, thus making the actual cost of construction work at this



time \$151,931,938.

The final closing date for the Stone & Webster Engineering Corporation contract numbers Y-7401-eng-13, W-14-108-eng-49, W-14-108-eng-60 was 30 September 1946, at which time the contract costs, exclusive of fixed fees, were as follows:

W-7 ^A 401-eng-13	\$361,275,244.37
W-14-108-eng-49	18,514,431.94
W-14-108-eng-60	16,408,018.67

Total All Contracts-----\$396,197,692.98

Of the above total cost of the three contracts, approximately \$300,000,000 was spent on the Y-12 Electromagnetic Plant and the remainder was for work done by Stone & Webster in the town of Oak Ridge. These figures do not include the fixed fees.



[REDACTED]

SECTION 3 - CONSTRUCTION PROGRAM

3-1. Mobilization.

a. General. - The construction of a plant of this magnitude, in record time, required an extremely well-organized and coordinated field force. The contractor gathered a large force of his experienced construction men from other jobs that were operating all over the country in order to fill the key positions and form the nucleus of his organization. This skilled group was augmented by many additional experienced construction personnel. The project was set up in divisions, each with a Division Superintendent and a complete field organization, under a General Superintendent. The General Superintendent coordinated the work of all divisions to keep an even flow of men and materials, to meet the changing labor demands and work priorities as they arose. The General Superintendent's staff included a Resident Engineer and several top men in the electrical, mechanical and piping trades, and material expeditors who planned, organized and coordinated work in various divisions.

b. Specialty Crews. - Many of the mechanical installations were developed solely for the Electromagnetic Plant, and, for security reasons, very little information could be furnished to the construction forces. Much of the special equipment required the use of highly skilled mechanics because of the accuracy and close tolerances that had to be maintained. As the average construction job rarely requires such exactitude, it was found necessary and desirable to train groups of mechanics to carry on certain of these operations, and then to move

[REDACTED]

them from building to building as the work progressed. This was also true of the special field engineer groups that laid out and checked the installation of the complicated equipment involved. Other groups assembled equipment furnished by manufacturers, requiring much precision work.

c. Special Tools. - The "specialty groups" and their supervisors were constantly on the alert to develop special tools and jigs which could be used to facilitate the work and reduce the overall time requirements (See App. B30). As soon as new jigs or tools were developed they were immediately made up in the project shops, with the result that in many instances the field forces could complete assembly of special equipment faster than outside contractors, and in many cases, parts were shipped to the job for field assembly, to save time.

d. Project Shops. - Efficient, well-equipped shops were set up at the start of construction to meet the needs of the job, and were expanded as the necessity arose. Very early in construction it was seen that the nature of the program, with the many new types of equipment constantly being improved and developed, required that many of the items should be fabricated on the job. Also, the rigid time schedule demanded by the District Engineer could not be met by outside shops over the country because they were overloaded with other work. Consequently, the Stone and Webster shops were set up to do either jobbing work or fast production line assembly, with the result that many items were obtained which could not have been obtained otherwise, and in many cases they were of superior quality and less expensive to the Government.



3-2. Building Schedules.

a. General. - In constructing a plant as complicated as Y-12, coordinated schedules for the starting and completion of various buildings had to be worked out which would make each necessary unit available to the operators at the correct time for it to fit into the operating sequence. Thus, even though the authorized Y-12 plant, in March 1943, consisted of three Alpha (first stage) process buildings, one Beta (second stage) Process Building, one Alpha and one Beta Chemistry Building, a Development Building and the numerous plant auxiliaries, it was necessary to schedule them separately in order to fit into procurement schedules and have the entire plant in operation by 31 December 1943 (See App. B3); it did no good to finish a building shell unless the process equipment was available for installation (For location and serial numbers of buildings, see App. D12).

b. Development Plant. - Building No. 9731 (See App. C16) was known during construction as the pilot plant, but it was never far enough ahead of the main plant to be more than a development and training unit. The Development Building was scheduled for completion at the earliest possible time, to take advantage of the operating experience that it would provide, prior to starting the main plant units.

c. The Alpha I Buildings. - In the two-stage electromagnetic process it was necessary to have the first stage in operation first to provide feed for the second, or refining, stage. The process buildings alone would have been useless without the chemistry buildings, the steam plant and other auxiliaries, including facilities for workers, such as

[REDACTED]

cafeterias and change houses. Therefore, the auxiliary buildings had to be scheduled along with the main process buildings.

d. The Beta Buildings. - As soon as the Alpha Buildings had been in operation long enough to produce enriched material, the Beta, or second stage buildings, had to be ready to complete the process. This meant that the actual construction had to be started at a time which would permit operation of Beta shortly after initial Alpha operation. Here again it was necessary to have chemistry buildings and auxiliaries ready ahead of the process building.

e. Alpha II Buildings. - The additional first stage units authorized with the major plant expansion (Y-12 Extension) were started during the period when all effort was being expended toward getting a large volume of production out of the initial plant, and so were pressed side by side with continuing Y-12 construction, using practically a new and distinct organization.

f. New Beta Buildings. - A second Beta Building was authorized in the Y-12 Extension to complement the additional first stage capacity, and since its immediate completion was not necessary, it followed a much less hurried schedule than the Alpha buildings. Later, when enriched feed from the Gas Diffusion Plant increased first stage production beyond expectations, it was necessary to build the third and fourth second stage buildings at a much more rapid pace.

g. Other Plant Schedules. - Throughout the construction program individual cases occurred which required that exceptional emphasis be placed on completion of certain items to suit design changes or new authorization. Building priorities were assigned which would result

[REDACTED]

In completion of this type of work when required.

3-3. Initial Construction. - In accordance with the previously mentioned schedules, the first process building to be started was Number 9201-1 (See App. C3). Excavation of the foundation of this Alpha Building was started on 18 February 1943, and at that time nothing more could have been started as the foundation drawings were the only approved plans in the field. Additional plans started to arrive, however, and by the time the concrete foundations were being poured for 9201-1 it began to look as if the whole valley was being torn up and moved. A boiler plant (Building 9401) (See App. C15) was started and foundations were being opened up for two more first stage process buildings (9201-2 & 3) (See App. C2, C10), Chemistry Buildings (9202 and 9203) (See App. C1, C12), an Administration Building (9704) (See App. C7), a cafeteria (9711-1), and the Development Plant (Building 9731). The approved plans for Y-12 plant at that time, consisted of: 3 Alpha Buildings, housing 5 first stage racetracks; one Beta building, housing 2 second stage racetracks; a chemistry group; and the necessary auxiliary and service buildings (See App. B3). The entire plant was scheduled to be completed by 12 December of that same year.

3-4. Foundation Problems. -

a. The Third Alpha Building. - The general location of the main process buildings was determined by sub-surface exploration borings. These borings indicated that the soft clay on the north side of the valley was underlain by about five feet of weathered shale and under that a firm bearing of Conasauga Shale. The underground formation at

[REDACTED]

the south side of the valley was made up of uptilted beds of dolomitic limestone of the Knox formation. Excavation for the third Alpha process building disclosed that the limestone was in a shattered and eroded condition which had not been apparent from the boring data. The resulting formation of large irregular boulders and crevices did not provide a desirable foundation; however, construction of the other process buildings was well along by this time, May 1943, and as all of the building locations were definitely correlated to meet operating requirements, it was decided that Alpha Building 9201-3 had to remain at the site selected. The builders refused to be balked by this problem and soon power shovels were at work stripping the entire foundation area. The shovels were followed by men who laboriously dug the clay and shattered rock out of the huge crevices. The exposed surfaces were then given a thorough water flushing with fire hoses, and a solid mat of concrete was poured over a large portion of the area. The mat was lapped over the ridges and large boulders in order to tie together the entire shattered limestone formation. Following a general grouting of the balance of the area, which consisted of pumping a mixture of cement, sand and water into concealed crevices through drilled holes, the construction of the building was ready to start again. (See App. B7).

b. Other Buildings. - Because of the problems encountered on the third Alpha building, extreme care was taken in the subsequent location of other buildings. As the scope of the project increased, it was possible to avoid the shattered limestone formation for all except the third Beta Building. (No. 9204-3). In view of the past experience, a reinforced concrete mat was poured over the entire area at basement

[REDACTED]

elevation. This eliminated the laborious hand excavation and cleaning of crevices and furnished a solid, level surface upon which to work, thus expediting construction of the balance of the building.

3-5. The Development Plant.

a. Construction. - As mentioned in Paragraph 3-3, it was of utmost importance that the plant operations have early use of the development and training facilities which were housed in the Development Plant (Building No. 9731). The building housed two experimental race tracks, each of which contained three magnet coils and two process bins. The XAX unit (See App. C17) was for Alpha stage development and training, and the XBX unit performed the same service for the Beta stage. The racetracks were supplemented by necessary material preparation and recovery equipment, control equipment and other auxiliary facilities (See App. B16). The reinforced concrete building, 107 ft. by 170 ft., was completed in record time (21 days for the superstructure), in spite of the many disheartening changes in arrangement which were incorporated as the work progressed (See App. C5, C13, C16). As soon as the shoring for the forms of the concrete roof slab could be removed, installation of the magnets was started. Each magnet consisted of three coils surrounded by huge steel yokes (XAX, 330 tons, XBX, 159 tons) which were made up of laminations ^Ccut from heavy steel plates. Construction of the yokes was a time consuming and difficult process because, after erection, the interior faces of the yokes had to be ground smooth and true by hand grinding. The nature of the materials used in the building exacted unusual demands from the construction forces. Many

[REDACTED]

sections of the building were treated with special paint, the lower sections of walls in the KBX section were of glazed tile, and the floor finishing was very carefully done to avoid cracks and joints, which would have been hard to clean and would have invited losses of valuable material. Much of the piping and numerous vessels in the chemistry rooms were of stainless steel, glass, porcelain and other special materials demanded by the high purity and minimum loss requirements.

b. Construction Changes. - The XAX magnet, which was the first separation unit to be completed in the Y-12 Area, was ready for testing on 5 August 1943. Testing disclosed that the unit could not be operated because of rust and scale in the distilled water system used to cool the control cubicles (See App. B22). The firm of Sheppard T. Powell, specialist on water treatment, was consulted, and following its recommendations, a change was made in the piping system (later incorporated in all other similar installations) which permitted successful operation, and the magnet was turned over to the Tennessee Eastman Corporation on 19 August 1943 (See App. B21). The construction forces continued to make the authorized changes necessary for satisfactory operation, until the operator could organize its own maintenance force. The KBX magnet was completed in November 1943 but final completion of the building dragged out until mid-January 1944, because of delays in receiving chemical equipment (See App. B21).

3-6. The Alpha I Plant.

a. The First Alpha Building. - Following the foundation work

[REDACTED]

previously described, construction of the Alpha I process buildings proceeded with little difficulty until they were ready for equipment installation. Each building required fabulous amounts of process equipment, including the enormous oval shaped electromagnets, many process bins, source and receiver units, control cubicles, motor generator sets, vacuum systems, chemical recovery equipment and thousands of lesser auxiliaries (See Vol. 3 Design). Then the equipment began to arrive, the troubles really commenced, for it was impossible to get the proper equipment in the sequence that was needed for orderly installation. In fact, to get some items of equipment was extremely difficult and required much vigorous expediting. Separate warehouses were constructed at Midway, a warehouse area halfway between Oak Ridge and the Y-12 Plant, which provided storage space where secret materials and equipment could accumulate and be ready for installation (See Par. 3-24) (See App. C35).

Since 9201-1 was the first building of its type, it was necessary to use it as a sort of "guinea pig" to revise installations and to design improvements for later buildings. Considerable time was spent in setting up procedures and training special groups to erect equipment on a production basis. While the additional work of training required some additional time for the construction of the first building, it paid dividends many times over when similar installations were made in later buildings. Work on the first race track was well under way before the structure for the opposite end of the building was completed. The moment the overhead cranes were set and the concrete roof was poured, workmen began unloading the massive magnet coils and placing the heavy



core castings. The grinding of these castings, which were inserted as a core to the magnet coils (See App. C20), looked like an endless job when it was started; however, after performance tests were made on the first magnet, the design engineers were able to liberalize the specifications to eliminate a substantial amount of the grinding. The first core castings were handled by big overhead cranes but it was soon discovered that the job could be speeded by use of truck cranes operating in the building. Installation of the control cubicles was delayed somewhat by lack of parts and by the amount of field assembly work necessary to place them in operation; later installations were successively speeded up as the installation crews became familiar with the work. To meet security requirements, parts of the buildings were partitioned off as soon as construction reached an advanced stage, and all workmen were required to have special passes for admittance to these restricted areas. On the first building the resulting confusion was a handicap, but, as the men became used to the restrictions, the confusion was overcome and satisfactory progress was achieved for the balance of the work (See App. C8, C14, C20).

b. Initial Operation. - The first racetrack (See App. C19) in building 9201-1 was ready for preliminary operation on 1 November 1943; during the trial run period, the magnet coils showed a very low resistance to ground which indicated that the insulation was not functioning satisfactorily. By 4 December 1943, after several of the coils had failed, a committee of experts was appointed to determine the cause and correction. The failure was determined to be caused by "shorts" due to

[REDACTED]

moisture in the cooling oil and insulation, and the presence of mill scale and other magnetic materials in the oil lines. The committee recommended that all coils should be returned to the manufacturer for cleaning and rewinding. It was also necessary to tear down and clean all oil lines in that building and adopt stringent cleaning specifications for all future installations (See App. B9, B23, B24). Meanwhile, the second track in this building was ready for drying out. This was accomplished by first circulating preheated oil through the lines, vacuum drying and then gradually energizing the magnet coils. By the adoption of this procedure, the original failure was avoided and Alpha Track No. 2 became the first track to be placed in operation. It was turned over to the operators on 31 January 1944 (See App. B25).

c. Rebuilding of the First Track. - To offset the disheartening delay occasioned by the failure of the first track, work was speeded, seven days a week, 24 hours a day, to get it into operation. To accomplish this, the magnet coils scheduled for the fifth track in another building were used, and Track No. 1 was turned over for process operation on 5 March 1944, six weeks after the start of rebuilding (See App. B21).

d. The "Walking" Tanks. - Another experience which "bedeviled" the constructors on the first track was the case of the "walking" tanks (process bins). Shortly after the initial magnet tests, it was discovered that the huge 14-ton tanks, wedged between magnet coils, had moved out of position as much as three inches, putting a terrific strain on the vacuum piping connected to them. The correction was simple after it was discovered that the magnets exerted a force

[REDACTED]

between the back to back tanks which forced them apart. After being securely welded in place by tie straps the tanks stayed put. (See App. #25).

3-7. The Original Beta Process Building. - The original plan for Y-12 contained only one Beta, or second stage, Process Building (No. 9204-1). Work on this building was started 15 May 1943 (See App. #21) and was much more exacting because of the design precautions taken to prevent loss of the valuable enriched material to be handled. Also, during the summer of 1943, it seemed as though there was just not enough manpower to handle all the rush jobs. The recruiters were sending in new men daily, but the workers were leaving as fast, or faster, than the new ones arrived, largely because of the difficult living conditions. Trailers and hut camps were being established, but were grossly inadequate for the men desiring accommodations, and conditions in surrounding localities offered very little relief. Transportation from surrounding territory was also a handicap, and in addition increased the absentee rate, for very often the driver of a car would not make it to the job and his riders, numbering 4 or 5 were then also absent. In spite of these many obstacles, and while the work on Alpha buildings was going at full speed, construction on the first Beta Building was accelerated to meet revised completion dates. Construction of the foundations for the Beta building, which were of the spread footing type, was tedious because of the many underground cavities encountered, which required much hard work by hand labor. The second shift of carpenters, established for the development plant construction, was now moved to this location and the building took shape very rapidly. There was no such thing as

[REDACTED]

one craft completing their work prior to the admittance of some other craft. It was really amazing even to experienced construction men, to see the many miles of electrical conduit, interwoven with additional miles of pipe of all descriptions, emerge in a well-ordered and arranged assembly. It was a common cry that the sheet metal men would not have room for their massive ducts or that some other tradesman could not possibly get in all the equipment shown; but by coordinating the work, everything seemed to come out right in the end. While the major forces were concentrated in the building, other groups were in isolated buildings, fabricating bus bars and assembling the intricate units to be installed in the tracks, (See App. C41); and from other sections of the area, trucks were continually bringing in materials of all descriptions. When the deadline date was reached for the operators to take over the first Beta track on 13 March 1944, one would not recognize the building-chemistry areas ^{which} were shining with new white paint and glistening with stainless steel kettles, sinks, and numerous gadgets. All through the construction program, it was often necessary to work beyond the 10-hour day limit to meet schedules, and hardly a Sunday went by on which some part of the operation was not in full swing. The first Beta Building was finally considered complete in September 1944 (See App. B21).

3-8. Original Chemistry Buildings. - A major phase of the electro-magnetic process is the chemical treatment of feed material and salvage operations, which required chemistry buildings of an unusual type. Excavation was started on the 2nd of February 1943, for the Beta Chemistry Building (9203) and on the 20th of February 1943 for the Alpha Chemistry Building (9202) (See App. B21, C1); however, design changes caused some

[REDACTED]

delay in getting equipment to the field, so that sustained construction did not get under way for several months (See App. C11). Also, it was deemed more desirable to concentrate the major efforts on the first process building and other auxiliaries that were necessary for actual production. The building to house Alpha Chemistry included Liquid phase, Vacuum Distillation, a small vapor phase with rotary reactor for continuous process and Bulk Treatment process. (The initial small continuous vapor phase process mentioned above was closed down in early 1944 due to operational difficulties and lack of capacity and was followed in 1945 by a larger Batch Vapor phase plant of the Harshaw type with a large rotary drum which replaced the Liquid Phase process.) The Alpha building was finally completed (See App. C13) and before long, a large scale extension was made to take care of expanded operations for the Vacuum Distillation, Liquid Phase and Bulk Treatment plants. After the construction forces were out of the building they were called back to add a hexafluoride pilot plant for converting enhanced material from K-23 and to convert the Bulk Treatment process to the Larson process—a cold precipitation process developed by the operating company (See Vol. 3 Design.) This building contained the first large scale installations, on the site, of very fragile, glass-lined tanks and pipe, which required constant protection to keep workmen from damaging them. After the original parts of the building were placed in operation on 29 September, 1943, there was continual changing and rearranging of equipment. All during the time the major building was going ahead, the auxiliaries, such as cooling tower, pump houses, chemical storage buildings, and the Beta laboratory, were also being pushed to completion

[REDACTED]

because they were all needed with the initial portions when taken over for operation. The construction men were also plagued by many lesser headaches, such as obtaining suitable gaskets that would withstand the corrosive materials and pressures used in the processing. The construction forces completed the original work and revisions thereto for the Alpha Chemistry Building in August 1945 (See App. B21). Building 9203 for Beta Chemistry had much the same early history as the Alpha Chemistry Building (See App. C12, C15). It was partitioned off in small rooms and, after framing, the interior proceeded by individual rooms as the chemical processes were worked out by the designers. Building 9203 was eventually replaced by a larger Beta Chemistry Building (9206) (See App. C22) and it was converted for laboratory use when Building 9206 was available for occupancy (See Volume 3 Design.)

3-9. Administration and Service Buildings. - In following the construction of the process buildings one should not lose sight of the many auxiliary buildings which were necessary to plant operation. These may be divided into two groups: frame construction and masonry construction (See App. D6).

a. Frame Construction Group. - The frame construction group, included administration buildings, guard headquarters, fire stations, change houses and cafeterias (See App. C48). A machine shop (9709) was provided where tools, equipment and appliances could be repaired in the course of plant maintenance. All automotive repair was handled in a fully equipped garage (9712). A complete laundry (9728) was built to take care of the washing and mending of uniforms worn by the operators

[REDACTED]

in the process areas. One Ammonia Storage Building (9713) was of frame construction while a similar structure (9743-2) for the Y-12 Extension was built of tile. The ^majority of temporary buildings were of frame construction. These structures included the warehouses and offices of Stone and Webster Engineering Corporation's Division, miscellaneous shop buildings, canteens and stationary and portable quarters (See App. D15).

b. Masonry Construction Group. - Several of the service buildings were of masonry construction because of the nature of the service or because of fire or other hazards. The principal masonry buildings are: a medical building (9706), a dry ice storage building (9737), a liquid nitrogen storage building (9727), an electrical maintenance shop (9737) fully equipped with testing apparatus, a foundry (9738), and numerous pump houses. (See App. B21).

c. Completion Statistics. - As mentioned previously, construction of all service buildings was carried on simultaneously with the main process buildings. These facilities were turned over to the operator as soon as available. The steam from the first boiler house was turned into the mains 1 July 1943, and on 9 July the Fire Station was occupied; meals were served in the first cafeteria on 28 July 1943; the first warehouse was occupied on 5 July 1943; the first office building was occupied on 19 July 1943 and the medical building on 13 August 1943. The main machine shop was taken over 12 August 1943, and the laundry started operation 16 August 1943.

3-10. Y-12 Extension. - In September 1943, the construction of the Y-12 Plant was going full blast, and with almost 10 thousand men working on the job, which was estimated at well over 100 million dollars, it was evident to those in charge that they had a pretty big job. On

[REDACTED]

the 11th of September they had a bigger one, because on that day, General Groves authorized the construction of an addition to the plant which more than doubled its size. This addition, which became known as Y-12 Extension (See App. C36, C37), included two new Alpha Stage Process Buildings housing two racetracks each, an addition to the Alpha Chemistry building (9202) (See App. C46), a second Beta Stage Building (9204-2) containing two racetracks, a new Beta Chemistry Building (9206) and many auxiliary buildings. The job was of such magnitude that additional field forces were set up paralleling in many respects the current Y-12 organization (See App. D10). Construction in the original area did not decrease rapidly enough to permit transfer of manpower in any quantities to the Extension Area until early spring in 1944 (See App. D11). The critical labor situation all over the country was reflected here, in the inability to obtain labor in desirable numbers. This problem was also aggravated by the other large scale operations on the reservation, as the Townsite and K-25 areas, each with large manpower requirements, that were operating under the same rigid time schedules as Y-12. However, the labor shortage never seriously handicapped operations because there was always some way to overcome this obstacle (overtime work was a common device to this end).

3-11. New Alpha Construction.

a. General. - The Alpha II Process Buildings 9201-4 and 9201-5 are the largest buildings in the Y-12 Plant. Each measures 543 feet by 312 feet and stands some ninety feet above the floor of the valley. In some respects the new Alpha II buildings, being of steel

[REDACTED]

frame construction and corrugated asbestos siding, provided simpler construction; but, with the vast increase in size and the many new features added, the actual construction of these buildings involved many more manhours than the Alpha I type. The field forces by this time were familiar with the problems of handling and installing equipment, and sufficient crews of trained men with their special equipment were transferred from Y-12 to the Extension to permit the formerly difficult jobs to proceed with comparative ease. The radical change in design for the racetracks, from the former oval shape to the rectangular arrangement, also made the installation of equipment simpler. One of the slowest jobs experienced in the earlier Alpha buildings was the stacking and grinding of the many castings installed by the field forces to make up the completed coils. The Alpha II coils came in as a complete unit filled with oil and ready to be connected into the system.

b. Construction. - Excavation for building 9201-4 started on 2 November 1943, and by 15 April 1944, steel erection was complete. Building 9201-5 was started on 27^o January 1944, and on 23 May 1944, the steel work was topped out. The work on the two buildings was scheduled so perfectly that even before the steel framing was finished, three quarters of the concrete floors had been poured, half of the walls were in place and much of the mechanical equipment had been installed. The various building trades normally wait for another trade to finish up before moving in, but here men were working under, over and around other craftsmen. The roof had its water blanket insulation, the exhaust

[REDACTED]

fans were in service, and much of the machinery had been tested before the last piece of corrugated transite siding was put in place. The work was well planned and progressed with breakneck speed, yet a near-perfect safety record was achieved. (See App. C23, C26, C31).

c. Alterations. - The operating contractor's forces began testing and operating the newly acquired equipment as soon as it was installed. Their studies, in addition to adding to the general complications, resulted in authorized changes to improve the operability. After having run the first race-track for a few weeks, it was decided that the recovery equipment should be modified to improve efficiency, and that additional space was necessary for handling tank liners. These changes resulted in a 40 by 240 foot extension to each Alpha II Building for "plate wash and recovery facilities" (See Vol. 3 Design). This addition had just been completed when alterations were required to provide faster access to the control cubicles for tube replacements. These giant panel boards with their mass of lights, dials and oscilloscopes were the nerve centers of the process but they were burning out electronic tubes faster than they could be trucked into the building. As a result, tube storage sheds were built as lean-tos on the building. Another change was the expansion of the cooling system for the 7000 horsepower motor generator sets.

d. Completion. - There was no definite time that could be set for the completion of any facility in the electromagnetic plant because relatively few items were ever finished according to the original plan. Instead, major additions and alterations, to take advantage of the latest developments, were started at various times during the

[REDACTED]

course of the work. For this reason the best measures of construction time are the dates when the race tracks were turned over for operation (See App. C32). The enormous speed with which Y-12 Extension was built may be high lighted by comparison with the original Y-12 Plant, which took a little less than a year from the breaking of ground to successful operation of the first track. By contrast, the first of the huge Alpha II tracks (Alpha Track No. 6) went into operation 17 July 1944, eight months after the building was started. Alpha Tracks 7, 8 and 9 were turned over on 10 August, 12 September, and 1 October 1944, respectively (See App. B21).

3-12. The Second Beta Process Building. - The schedule for the second Beta Process Building (9204-2) was one of the few schedules which did not call for breakneck speed. Construction began on 20 October 1943, and proceeded in an orderly manner throughout. The first concrete was poured on 23 October 1943. Work progressed from West to East with pours starting on 2nd floor concrete on 15 January 1944, and on low roofs on 1 February. The crane bay roof trusses were erected by 21st March and the two overhead cranes were installed by 1 April. The outside tile walls were started then and the application of the built-up roofing began 21 April 1944. (See App. C27, C30, C34). Equipment setting began on 1 April and the first track (Beta No. 3) was turned over to the operators 10 September 1944. Track ^{No.} 4 was turned over to the operators on 7 October 1944 (See App. B21).

On 15 November 1944, all work on the second Beta Process Building was completed with the exception of the chemical area. This work had been started but changes in design delayed its completion. The schedule

[REDACTED]

of work was dictated by equipment deliveries and completion was finally accomplished 15 April 1945.

3-13. Chemical Facilities With the Extension. - The authorization for Y-12 Extension, in September 1943, included an addition to the Alpha Chemistry Building (9202) (See App. C42, C46) to handle the feed recycle material from the new Alpha race tracks. The authorization also included a new Beta Chemistry Building (9206) to replace Building 9203, which was now too small and could not be satisfactorily enlarged. During the construction of Building 9206, the field forces experienced the same difficulty as in the previous chemical building, that of the need of constant rearrangement and revamping the equipment. The building was occupied by the operator in October 1944, although alterations continued for some months.

3-14. Construction of the 9207 Group. - An entirely new group of Alpha Chemistry Buildings became necessary in June 1944, to provide for large quantities of enriched feed material to be obtained from the Gas Diffusion Plant (See Vol. 3 Design). The new group consisted of a six-story process chemical building, a chemical storage building, change houses, pump houses and tank farm. These were supplemented by an incinerator building, a vacuum distillation building, a compressor building, a hydrolysis tower, and an ammonia storage building (See App. C44, C47, C49). The major chemical buildings were of steel frame construction and incorporated many of the improvements in design and equipment that had been developed since construction of the first chemistry facilities.

[REDACTED]

Large quantities of Pyrex pipe, varying from 1" to 4" in diameter, were used. In order to speed the installation of this glass pipe, complete facilities were set up at the job to weld, bend, and fabricate special fittings. As this type pipe was new to the average mechanic, it was necessary to train men, under the direction of an engineer from the Corning Glass Works, in order that sufficient experienced men would be available for efficient installation. Other unique features of the chemical buildings were the numerous dry rooms, used for handling material, wherein the temperature and the humidity were accurately controlled. To protect the operating personnel from fumes in the process areas, elaborate ventilation systems were installed, designed to provide up to 30 changes of air per hour in hazardous sections. All finished floors were of smooth concrete laid with special care to prevent cracks or openings. Floor areas that might come in contact with acid were protected by acid-resistant tile or stainless steel plate. Construction of the major part of the 9207 Group was stopped in June 1945, because increased enrichment of the Gas Diffusion Plant product made it desirable to feed K-25 material direct to the Beta stage at Y-12, thus eliminating the Alpha stage entirely.

3-15. The Third Beta Process Building. - A third Beta Process Building and auxiliaries were authorized in May 1944, to handle the increased Alpha production expected because of the enriched feed. This new building (9204-3) was similar in arrangement to the two earlier buildings but was changed structurally (See App. C40, C45). Steel framing was used instead of the earlier reinforced concrete, and the change houses

[REDACTED]

were incorporated in the building. Site grading for 2204-3 started 15 May 1944, and Tracks 5 and 6 were turned over for operation 25 November 1944, and 8 November 1944, respectively (See App. 221). Building completion was achieved 15 May 1945, after numerous changes to the Chemical area.

3-16. The Fourth Beta Process Building. - On 2 April 1945, under Contract No. W-14-103-eng-60, a fourth Beta Process Building (2204-4) was authorized, to handle increased production resulting from Gas Diffusion Plant feed. Construction started ¹¹ April 1945, duplicating the design of the third building (See App. 221). By 1 July 1945, the structure was well underway and equipment installation had started. Completion was scheduled for 1 December 1945.

3-17. Construction Status 1 July 1945. - By 1 July 1945, the major part of the Electromagnetic Plant was complete and in operation (See App. 251 and 252). There were 9 first stage race tracks, containing 364 separate process bins; 6 second stage race tracks, containing 216 process bins; facilities for handling and processing the feed material through the separation process; facilities for serving the huge operating staff of over 20,000 people. Some of the facilities were already obsolete or well on the way to obsolescence and new facilities were under construction to keep abreast of the rapid development of the Uranium Separation Process. Construction forces had dropped to about 6,600 workers and were gradually tapering off to an expected completion in January 1946 (See App. 221).

3-18. Utilities.

a. General. - The utilities at the Y-12 Plant were constructed and operated in conjunction with the Central Facilities for the Town of

[REDACTED]

Oak Ridge. The construction of these utilities was commenced early in the program and was revised and added to in accordance with general expansion. Then, in September 1943, when the Y-12 Extension was authorized, approximately doubling the size of the electromagnetic program, an extensive expansion to existing utilities was required. Still later, additional facilities were necessary in order to keep pace with new construction.

b. Water Supply System. - The Central Facilities water supply system consists of a pump house, with installed pumping capacity of 28.0 mgd., located on the Clinch River; two 24" diameter force mains running to a ^{17.5} 16 mgd. filtration and purification plant; and one 4.0 mg. and one 3.0 mg. storage reservoir located on a ridge between the manufacturing and townsite areas (See Book I, Volume 12 and App. D8). This system also supplies potable water to the distribution system of the entire Y-12 manufacturing area. Work was started 22 March 1943, by Stone and Webster's own forces and was placed in beneficial use on 25 November 1943. As forced draft cooling towers are used for removing heat ^{generated} in the process, ~~buildings of the manufacturing area,~~ ^{and} a large part of the make-up water is raw water taken directly from the force mains between the river water pump house and the filtration plant. Both raw and filtered water are chemically treated to prevent scaling. Make-up water for the cooling tower installation (See App. C24), reputed to be one of the largest in operation at the present time, constitutes the largest part of the water demand, 5.2 mgd., for the manufacturing area (See App. B27).

c. Sewage Disposal. - Process wastes from the manufacturing

[REDACTED]

area are treated and then collected, together with sewage, in the ^{sewer} sewage system for that area. The major part of this waste flows by gravity through the trunk sewer line. Originally, the waste passed through a pumping station and was pumped over a ridge and thence flowed by gravity to the East Treatment plant (See Book I, Vol. 12). This plant was constructed by Stone and Webster's own forces, work being started 16 April 1943, and was turned over for beneficial occupancy 18 November 1943. Later, the west sewage disposal plant was constructed by Stone and Webster. It was started on 15 February 1944, and completed for use by 30 May 1944. All sewage from the manufacturing area now flows directly by gravity to this location.

d. Electric Power. - In order to supply the ultimate power requirements for the manufacturing area and Oak Ridge, two high tension switching stations were constructed. The initial station (1501) was supplied with power by cutting the Watts-Bar-Norris line of the Tennessee Valley Authority system and looping it into the bus of this station. The second switching station (1501-2) was supplied from a new line about ¹⁴ ten miles long, constructed from Fort Loudoun Dam, with a tie line to the first station (See App. D12). Initially, the first station consisted of a single bus to take two incoming lines, with two outgoing feeders to the manufacturing buildings, and a 9000 kva. transformer, for supplying power to the Townsite and Administrative Area and for pumping facilities. Later, a circuit was added to this station to supply about 20,000 kva. to another manufacturing area in the reservation, and another circuit was added for the tie line to the second station (See Central Facilities, Book I, Volume 12). Process buildings were connected

[REDACTED]

to the feeder lines through load break disconnect switches with transformers to step the 154 kv. down to 13.2 kv. for building distribution. Because of the critical steel situation, wood pole construction was used for all of the transmission lines and for both of the stations (See App. B16).

e. Steam Plant. - Two boiler houses (See App. C15, C13) were constructed in the Y-12 Area; the first, to serve the initial authorization, was started 2 March 1943 and placed in operation 15 July 1943; the second, for the Y-12 Extension, was started 13 November 1943, and placed in operation 19 June 1944 (See App. B21). The first boiler house has a concrete foundation, brick exterior walls, precast concrete roof slab supported by concrete beams and concrete interior columns, and 6-ply, built up, slag-surfaced roofing. The second one has a concrete foundation, structural steel frame, corrugated asbestos siding, precast concrete slab roof, and 6-ply built-up roofing. The initial installation in the first boiler house consisted of two 600 hp. boilers, which was enlarged by the installation of two more boilers of the same size and also a final expansion of four more 600 hp. boilers. The second boiler house, which was initially provided with two 600 hp. boilers, was expanded in two stages by the installation of one additional 600 hp. boiler and then three additional 600 hp. boilers. The boiler house capacities were expanded in accordance with increased demands caused by new construction. All of the boilers had been in service at other steam plants and had to be disassembled, transported and erected at this site. All of the process steam and steam for the heating of buildings and structures are carried in overhead insulated steam pipes supported on wood pole structures.

[REDACTED]

3.19. Roads. - The main entrances to the Clinton Engineer Works are located at Elza, Edgemoor, Solway, White Wing Bridge and Gallagher Bridge, Blair Gate and Oliver Springs, from which county or state roads lead to primary highways connecting with Knoxville, Clinton, Lenoir City, Harriman and other surrounding towns. These towns afford living accommodations for the personnel working on the project who were not housed in the townsite facilities (See Book I Vol. 12). The Clinton Engineer Works area itself is traversed by three county roads in a generally east and west direction, known as "Bethel Valley", "Bear Creek" and "Wheat" (Oak Ridge Turnpike) roads. (See App. D13). These are all located in the main valleys of the project and are cross-connected by River, Seabore, Mountain View and White Wing Ferry roads. The Y-12 Area is located just south of Bear Creek Road and west of Seabore Road. The 10 miles of roads in the manufacturing area were laid out to serve the various buildings and structures in this area and were subject to much rearrangement during the different stages of building development. At first, the roads were graded, drained and built up with a crushed lime rock base of sufficient thickness to withstand the construction traffic. Gradually, as different portions were turned over for operation, the base was reshaped and a bituminous surface was applied. (See App. 328).

3-20. Railroads. - The Louisville and Nashville Railroad main line between Knoxville and Cincinnati forms the northeast boundary line of the Clinton Engineer Works, with the local freight station located at Elza, Tennessee (See App. D13). This is the entrance to the project where the main switching points are located, to transfer railroad shipments from

[REDACTED]

the L&N Railroad system to the project classification yards. A receiving, classification and material storage yard was constructed in the eastern end of the Reservation, which connects to branch lines leading to individual storage yards at Midway Secret Storage Yard and at the Y-12 Area. The Y-12 Area system, comprising a total of 7.2 miles, was developed to serve the installation and maintenance of the heavy equipment in the process buildings and shops.

3-21. Fences and Guard Towers.

a. Perimeter Fence. - A temporary perimeter fence which restricted the construction area was ready for use during the first part of June 1943. At first, the use of restricted entrances caused some confusion and delay but this observance soon became routine, as did all of the other necessary security measures on the job. A permanent fence and series of guard towers were completed and placed in service during October 1943 (See App.D7). This fence was erected with wooden posts, because of the scarcity of steel, and has 8 foot Cyclone fencing fabric with 2 foot side arms which carry 3 strands of barbed wire. The fence line was lighted by means of flood lights, mounted on poles which carry the necessary power supply lines. Access gates, which were operated by the guard force as described in Par. 5-3, allowed properly authorized personnel, material and equipment to pass in and out of all restricted areas.

b. Interior and Temporary Fences. - The interior fencing (See App. D7) was erected in order that further security measures would be maintained in the various highly restricted areas. The construction of this fence was the same as that of the perimeter fencing except that flood

[REDACTED]

lighting was not required. In addition to 5.31 miles of perimeter fence and 5.63 miles of interior fence, approximately 10 miles of temporary fence were erected during the course of construction in order to maintain proper security without delaying completion of the project.

c. Guard Towers. - The guard towers are of standard wood type construction, erected at the elevation required to provide the proper sight distance between towers necessary for adequate guarding. The towers are heated by electric heaters and equipped with vertical and horizontal manually operated spot lights.

3-22. Work Performed under Service Contract.

a. General. - Plant activities at Y-12 and Y-12 Extension, in the latter part of 1944, indicated the need for extensive changes in process and equipment. Tennessee Eastman Corporation, the operating contractor, had been constantly developing refinements in process which required major changes in construction. However, as Tennessee Eastman Corporation was shouldered with the usual operational difficulties and maintenance problems, these plant revisions, involving large expenditures of money, materials and labor, could best be carried out by a construction firm. Stone and Webster Engineering Corporation, nearing completion of their original construction contract No. W-7401-eng-13, and located at the site with an experienced organization, were selected as the firm most capable of fulfilling the exacting requirements of speed, engineering and construction. Consequently, a new contract, W-114-108-eng-49, was executed on 2 February 1945, which was to remain in force for six months, with the option of renewal for a six months period.

[REDACTED]

Work Authorities (known as "WA's") were requested by Tennessee Eastman Corporation and submitted to the U.S.E.D. Contracting Officer for approval of scope and expenditures. These requests were then forwarded to the engineering division of Stone and Webster Engineering Corporation for study, designs, plans, specifications, checking, and related requirements. Major changes developed by the Stone and Webster Engineering Corporation were re-submitted to the Contracting Officer and the Operating Company for further checking and approval. Prints were then issued to the field, for construction, in the form of WA's, carrying both the basic and supplemental WA numbers.

b. Scope. - A total of 480 WA's was issued up to 1 July 1945. Of this total, 113 were basic authorities for new projects, or for establishing policies and specifications. Twenty-nine requested additions or revisions in structure or equipment. Many were issued to clarify plans or specifications, and some to authorize miscellaneous contracts with other prime contractors on the area. The following were some of the major revisions performed under this contract.

WA numbers 1 and 3, with 66 supplementals, required extensive changes to equipment previously installed in Building 9202, an Alpha Chemistry Building. Revisions in piping, tank and pump additions, and the separation of a common system for bulk treatment to several single lines for flexibility in operation, were carried on during operations. Because of pressing requirements of speed, materials were borrowed from job stocks or purchased under high priorities from outside vendors. The plant refrigeration system was increased from 61 tons to approximately 90 tons, requiring extensive installations of pipe coils and insulation. WA

[REDACTED]

number 1, issued 7 February, and NA number 3, issued 13 February, were nearly completed on 1 July 1945. During this period, a total of 5,600 manhours and \$226,000 were expended.

NA number 8 and supplementals involved additions to the Plant Oxygen Distribution System. NA number 59 required extensive changes to the ventilating systems of Building 9206, the Beta Chemical Building. Estimated expenditures on this project were \$56,250 up to 1 July. NA's 32, 48 and 210 authorized installations of new lines of process equipment for this building. NA number 100, although not in Building 9206, established a new area to serve this building. Two large stainless steel storage tanks of 25,000 gallon capacity were erected for the process refinement, with the necessary pumps, piping and other equipment. This area was located at the westerly end of the Y-12 Plant. NA number 200 authorized construction of a receiving warehouse covering more than an acre of ground, built of steel framing originally fabricated for a similar structure at Lowell, Massachusetts.

e. Major Construction. - The largest single item under this contract was authorized by NA number 159. This item was the construction of a Beta Chemistry Building (9212), to be used for preparation of the final product, consisting of a two-story Head House with four one-story wings extending from the long side of the Head House (See App. C50). The building has steel framing, concrete spread footings and foundation walls, structural tile walls, and concrete floors. The floors, in general, are covered with linoleum, but certain rooms have floors of stainless steel, or nickel (See Vol. 3 Design). Roof construction is poured gypsum on sheet-rock, a light weight material, with standard built-up tar

[REDACTED]

and gravel roofing. All roofs are insulated to a specified heat conductivity factor. Under the first floor are pipe tunnels carrying all piping services for the entire laboratory area. Also, in the Head House tunnel area one section is set off as a refrigeration room, containing air-conditioning compressors and refrigeration equipment. Fire-proof lumber is used for furring all exterior walls and for intermediate room partitions. The walls are finished with fire-resistant sheet rock.

The first floor is composed of offices, laboratories, salvage and reconversion rooms, machine shop, stock rooms, and vaults. Most of the laboratory equipment is made of stainless steel, although certain of the hoods and sinks are of Alberene Stone, Transite, and Karbate, all resistant to various types of acids. Davis Gas Alarms are installed in many rooms to detect explosive mixtures, while certain rooms are protected with a CO₂ fire protection system. The building is windowless to aid rigid temperature and humidity control. The second floor of the Head House contains air conditioning equipment, supplying properly humidified air to the laboratories through large plenum chambers occupying all of the space above the first floor ceiling. Air exhausted through hoods is discharged to atmosphere by large fans at the extreme ends of the laboratory wings, eliminating remote chances of toxic fumes being drawn into the fresh air supply. However, this exhaust air is first processed through electric precipitrons to recover all solids and product, insuring no waste.

This chemistry building was authorized for construction 5 April 1945, with completion requested by 1 October of the same year. In normal

[REDACTED]

times, the design and construction would have required 18 months. It incloses a floor area of 126,330 square feet and contains 2,152,917 cubic feet. The structure, together with auxiliary buildings, includes a cooling tower and pump house, a cafeteria and a change house; it required 15,000 cubic yards of excavation, 25,000 cubic yards of fill, 5,300 cubic yards of concrete, 700 tons of structural steel, 300 tons of reinforcing steel, and 238,000 pieces of structural tile. On 1 July the design was 95 percent complete, orders for materials and equipment were 98 percent complete, while only about 3 percent of the process equipment had been delivered to the site. The structure on that date was 36 percent complete (See App. B21).

d. Review. - On 1 July 1945, 480 WA's had been issued, 160 were fully completed and 320 in progress. At that time the force employed on this work was 4,535. An estimated total of \$7,656,900 had been expended on materials and labor. Work which was not completed on the previous contract was necessarily concluded under the terms of this contract, at a cost of approximately \$1,167,500, which cost is included in the above total (See App. B5).

3-23. Temporary Facilities.

a. General. - Numerous temporary buildings were provided to facilitate the construction of the Y-12 plant. Separate shops, office buildings, time offices, warehouses, etc., were built for the various divisions of the Stone and Webster Engineering Corporation. Much of this temporary construction, when no longer needed by the construction forces, was transferred to Tennessee Eastman Corporation, to facilitate their

[REDACTED]

operation of the plant, thus achieving maximum economy. A tabulation of these facilities, all built by Stone and Webster, is to be found in Appendix D13. The following is a discussion of the major items (See also App. Ch. C28, C29).

b. Warehouses. - Five buildings, 60 ft. x 200 ft., with concrete floors at car-floor height, were constructed at Midway (See App. C35), a specially fenced and guarded area used to store secret equipment which arrived prior to its scheduled installation. When Y-12 Extension was added to the project, three additional warehouses were constructed at this site. Two of these were 40 ft. x 400 ft. and one was 48 ft. x 192 ft. These also had concrete floors but just above the ground level and not at car-floor height. (See App. B29).

c. Shops.

(1) Machine Shops. - A special machine shop was built by Stone and Webster to manufacture certain items which could not be secured in time from outside manufacturers, to alter other items, and to make necessary repairs. The machines and tools installed in this shop were varied and extensive, and practically any kind of machine work could be accomplished. One instance of the value of this shop is indicated by the fact that when turntables were required to rotate 50-ton coils through 90°, this shop designed, built, and had the equipment in operation within 48 hours. Procuring these special turning devices would have taken perhaps 60 days through other channels. (See App. B30).

(2) Pipe Shops. - The Pipe Shops were set up for cutting, threading, welding and bending pipe. There was also an installation for

[REDACTED]

the fabrication of pyrex piping. Originally, the piping for oil distribution, and later piping for other purposes, was cleaned by pickling, and it was necessary to erect pickling vats and handling equipment. The interior of a part of the piping was also sand-blasted and painted, and it was necessary to set up sand-blasting sheds and pipe paint shops. The valves received at the job and used in oil cooling lines were dismantled and pickled or sand-blasted and the interiors were painted.

(3) Carpenter Shops. - The Carpenter Shops constructed cabinets, lockers, tables, benches and millwork which it was not possible to procure from outside manufacturers within the required time. The inclosures around the operation tracks in the manufacturing buildings were also built in these shops.

(4) Miscellaneous Shops. - All sheet metal work for extensive ventilation and other purposes was fabricated in the Sheet Metal Shops at the job. These shops were furnished with all the machine tools necessary to do this work. The Paint Shops were used principally for painting the interior of valves and piping and the millwork manufactured in the Carpenter Shops. The Plate Shops were used to fabricate the steel plates used for the magnets in Building 9731 and the various Beta buildings. A building 30' x 96' was constructed to fabricate and bend silver bus bars. This was a closely guarded operation (See Volume 4, Silver Program). Practically all of the automotive and construction equipment was serviced and repaired in the Automotive and Machine Shops which also did work required by the Townsite Facilities.

d. Office Buildings. - Office buildings for the General



Superintendent's organizations were constructed both in Y-12 and Y-12 Extension. Stone and Webster's General Accounting Office and Local Purchasing Department were located in the Main Administration Building in the Townsite Area. The main office and facilities of the Personnel Department, who hired all employees at the job site and kept all employment records, were originally located in the Townsite Area on Route 61, but later, when this building was taken over by Tennessee Eastman Corporation, a new Personnel building was built at the east, or Elza Gate, entrance. This building contained vaults for storing employment records.

e. Miscellaneous Temporary Facilities.

(1) Canteens. - Eight canteens, 28' x 50'8", were constructed in the two areas, to furnish lunches to the workmen.

(2) Clock Alleys. - The clock alleys constructed were sectional and could be readily moved when the necessity required.

(3) Stone Crushing and Concrete Mixing Plants. - The crushed stone for roads, as well as some of the concrete, was furnished by Ralph Rogers Company from two quarries located in the valley south of the Y-12 area. This material was furnished under two contracts (W-7418-eng-3 and 66) which totaled \$549,972.66.

The ready-mixed concrete was purchased from Transit Mix Concrete Corporation under Contract No. W-7418-eng-4 in the amount of \$1,975,627.73. The contractor located a batching plant on the railroad spur near Soarboro Road, about three-quarters of a mile east of the East entrance to the Y-12 area, in order to facilitate the handling of materials.



f. Equipment. - The construction equipment used in Y-12 was varied and extensive and consisted of:

- | | |
|---------------------------------|----------------------------|
| 35 Cranes, Shovels and Backhoes | 76 Hoists |
| 600 Trucks | Light Plants |
| 655 Welding Machines | Concrete and Mortar Mixers |
| Pumps | |
| 131 Air Compressors | Saw Higs |
| 23 Road-Grading Machines | Vibrators |
| 9 Rollers | Earth Drills |
| 2 Ditching Machines | 80 Tractors |
| 18 Material Hoists | 76 Sedans |
| 8 Derricks | 7 Station Wagons |
| 68 Concrete Finishing Machines | 36 Busses |

g. Temporary Roads. - The construction roads in general were built on the location of the permanent roads, but it was necessary to build other temporary roads. On account of the heavy concrete-mixing trucks and other trucks loaded with heavy materials and equipment, it was necessary to surface these temporary roads with crushed stone.

h. Facilities for Night Work. - Temporary lighting was required for night work, and this, together with the electrical welding machines and other motor-driven construction equipment, required the installation of a temporary electrical distribution system. Portable lighting plants were used where that method was more economical than extending the temporary lines.



[REDACTED]

SECTION 4 - MATERIALS OF CONSTRUCTION

4-1. Procurement. - It would be a mere cliché to say that the procurement of materials for the construction of the electromagnetic project was an indispensable factor in the successful completion thereof. Because of the size and diversification of the project, it was deemed necessary to establish two distinct Purchasing Departments, one of which, in the Boston Office of Stone and Webster Engineering Corporation, was primarily concerned with the procurement of process equipment; the other, with headquarters at Oak Ridge, Tennessee, dealt with structural materials and associated items. The functions and activities of the Boston Office, except for fleeting references, are discussed in Volume 3 of this Book. Standard Stone and Webster Engineering Corporation purchasing procedure proved invaluable; e.g.: division of responsibility for purchasing and subsequent expedition of the purchase order. The nature of the project involved the procurement of vast quantities of such critical material as steel, copper and alloy pipe. However, thr^{ough} timely discussions between Stone and Webster Engineering Corporation Purchasing Department and War Production Board with the mediation of Liaison Office of the Manhattan District in Washington, orders were placed within two days after authorization for construction was received from an official source. Mention should also be made here of the valuable assistance in the procurement of construction equipment rendered by Government surplus pools and other Government agencies.

4-2. Expediting. - Simultaneously with the placing of a purchase order by the Purchasing Department, the Inspection-Expediting Department

[REDACTED]

went into action. At first located in Boston, Massachusetts, the department was moved to Oak Ridge, Tennessee, during April, 1944. As the volume of purchase increased, so did the expediting department grow and eventually reached a peak of 119 Field Inspector-Expeditors, 26 Schedulers, 9 Priority Men, and 85 Field Stenographers, Typists and Clerks. Branch offices were maintained in Chicago, Illinois; Los Angeles, California; New York, New York; Philadelphia, Pennsylvania; Pittsfield, Massachusetts; Pittsburg, Pennsylvania; Rochester, New York; Springfield, Massachusetts; San Francisco, California; Schenectady, New York; and Toronto, Ontario. The heavily stressed basis of operations was expediting raw materials into the fabricators' plants. This necessitated expediting thousands of suborders placed by contractors and vendors, in addition to contracts and purchase orders originating with Stone and Webster Engineering Corporation. A nationwide canvass of sources of materials and equipment was vigilantly maintained, and on approximately 80 percent of all orders, it was necessary to assign competent personnel to the manufacturer's plant to make an inspection of the product. In many cases it became imperative for the expediting department to develop an alternative source of supply or find a subcontractor whose facilities were more adequate. All means of shipment were scrutinized and the one deemed most advantageous was selected. Every prime contract, sub-contract, modification, purchase order and memorandum of change was handled by the Expediting Department, as well as all suborders placed by contractors and vendors. To illustrate the efficiency of the purchasing and expediting departments, it is not irrelevant to state that, through revisions and credits, \$27,391,654.33

[REDACTED]

were saved in the procurement of equipment for Alpha 1 and 2, and Beta 1, 2 and 3 processes alone. This saving was in no small part due to the alertness of the aforesaid departments in expediting deliveries of raw materials and sub-contract parts.

4-3. Receipt and Distribution. - Receiving, warehousing and distribution of material for construction of such scope as the work at Clinton Engineer Works involved one of the most intricate problems of management. Facilities, at first somewhat primitive, rapidly expanded as the tempo of construction activities and the concomitant influx of materials and equipment increased. A transportation system, including roads, railroads and classification yards, was developed as rapidly as possible, and was followed by the inception of a warehouse building program in the electromagnetic project area (See Paragraph 3-24). Trucks transporting material and equipment from the original central and receiving depot were, at first, sent directly to the area receiving department, whence a man accompanied each truck to its ultimate destination to check its contents. It was found necessary, for a time, to dispatch a guide with each truck to prevent undue loss of time between the area entrance gate and the receiving office. With the construction of warehouses, all carloads, and some LCL shipments, were sent directly to the area, and their contents were distributed to buildings under construction or to their proper warehouses. Each division was allotted a warehouse, in addition to general piping and electrical warehouses--a division comprising, in general, a major process building and its appurtenant minor buildings. Because of the quantity and complexity of instruments required for a project of this scope, it was also considered

[REDACTED]

advisable to establish a separate instrument warehouse. Process equipment, which was of a highly secret nature, was stored in a specially provided area, under armed guard, and was unpacked only at the site destined for its ultimate installation. Statistics illustrative of the quantities of material received are found in Paragraph 4-5.

4-4. Disposal of Scrap. - Inevitably, a great amount of scrap metal accumulated during construction of the plant. During the earlier stages of construction, Stone and Webster undertook the disposal of such scrap material by offering it for sale to the high bidder, the proceeds then being turned over to the Government. A sum of \$15,148.03 was realized through this method of disposal. This procedure was changed, however, by order of the District Engineer, and, on and after 1 July 1944, all scrap and non-repairable property was turned over for disposal to Roane-Anderson Company, the operating contractor for Central Facilities (See App. B11). A total of 2,771 tons of miscellaneous metal scrap had been so turned over to the Roane-Anderson Company during the period ending 30 June 1945. This scrap weight reached 4962 tons by 31 December 1945, and 6515 tons by 31 December 1946. All such scrap material is segregated as to type by the Roane-Anderson Company and disposed of ^{to} ~~at~~ the highest bidder. Each sale is approved by a government representative.

4-5. Construction Statistics

a. General. - An interesting feature of the construction program is the enormous quantities of materials and supplies that were used to build the electromagnetic plant. Because of the speed of construction schedules, it was mandatory that construction materials and



equipment of all descriptions be mobilized at the earliest moment. As all phases of construction were started as soon as plans were available, a multiplicity of the same types of equipment were required. All known sources were canvassed for the necessary supplies; material was purchased from private concerns, rented from contractors or sales organizations, transferred from deferred or completed government projects, and, in some instances, new facilities were constructed in order to meet the requirements. Carload after carload of specialized electrical and mechanical process equipment was shipped well in advance of actual installation so as not to delay construction. This influx of equipment clogged the railroad facilities for miles around the project and created a major unloading problem. Much of the material was of a secret nature and had to be stored in highly restricted and patrolled warehouses, large quantities of other materials were just unloaded along the track, or in any empty building or shanty that could be found. The following tabulations are indicative of the task that confronted the Engineers.

b. Peak Carload Receipts (See App. B8).

<u>Quantity</u>	<u>Description</u>
54	Cars of ties received in one week
11	Cars of valves received in one week (three different weeks)
41	Cars of wallboard received in one three-week period
63	Cars of concrete blocks in one four-week period
31	Cars of brick received in one week
128	Cars of electrical material in one two-week period
560	Cars of electrical material in one eleven-week period
1585	Cars of lumber in one eleven-week period
110	Cars of pipe and fittings in one two-week period
15	Cars of plywood in one two-week period



c. Total Car Receipts of Certain Material (See App. B8).

<u>Item</u>	<u>Quantity</u>
Coal and Coke	946 cars
Elect. Material	2157 "
Heavy Equipment	1219 "
Lumber	5389 "
LCL Merchandise	2113 "
Operators Cars	4514 "
Pipe and Fittings	1407 "
Sewer and Soil Pipe	1172 "
Steel	1188 "
Tile	1236 "
Valves	257 "
Welding Electrodes	11 "
Anti-freeze	7 "
Bolts and nuts	24 "

d. Representative Quantities for Y-12 Area (See App. B8).

TABULATION OF MATERIAL

<u>Item</u>	<u>Quantity</u>
Excavation	1,000,000 Cu. Yds.
Concrete	275,500 Cu. Yds.
Lumber	37,562,000 F.B.M.
Brick	4,900 M.
Concrete Blocks	6,000 Ea.
Tile, Structural	5,284,000 Ea.
Corrugated Asbestos	146,000 Sq. ft.
Wallboard	2,332,000 Sq. ft.
Asphalt Shingle	
Roofing	486,000 Sq. ft.
Built-up Roofing	1,937,000 Sq. ft.
Windows	13,100 Ea.
Doors	4,400 Ea.
Precast Roof Slab	82,000 Sq. ft.
Asphalt Tile Floor	26,600 Sq. ft.
Sewer Lines	61,500 L.F.
Water Mains	55,000 L.F.
Steam Mains	28,600 L.F.
Crushed Limestone	554,800 Tons

[REDACTED]

SECTION 5 - LABOR RELATIONS, SAFETY & SECURITY

5-1. Labor Recruitment and Industrial Relations.

a. Procurement of Labor.

(1) Local Offices. - Procurement of personnel necessary for the construction of a project of the size of the electromagnetic project at Clinton Engineer Works, during a time when the labor situation throughout the country was already most stringent, was an employment problem requiring a very large amount of planning work, screening and an extensive distribution of employment offices. Key personnel for Stone and Webster Engineering Corporation was supplied through the Boston Office of the organization, but by far the greater part of the manpower was hired at the job offices. A few persons were hired at the temporary headquarters at the Andrew Johnson Hotel in Knoxville, Tennessee, but procurement began in earnest with the establishment of an employment office, on 6 November 1942, at 931 North Central Avenue, Knoxville (See App. B13). Immediately after the organization of the Personnel Department, conferences were held with representatives of the Building Trades Council, the various labor unions, the United States Employment Service ^{of} and the War Manpower Commission, during which the scheduled requirements of the project were discussed. The urgency for and importance of obtaining adequate manpower were constantly emphasized, and the several agencies assured the personnel department of their cooperation.

(2) Distant Sources of Labor. - It soon became mandatory

~~CONFIDENTIAL~~

to establish a recruiting service, and recruiters were stationed in the larger labor centers of practically every state in the southeast portion of the United States. The first personnel hired through this channel arrived on the job 13 May 1943, and there was a steady influx of such manpower until recruitment was abandoned in September, 1945 (See App. B14). After ~~1 July 1945~~,^T the shortage of electrical workers became so acute that special measures were instituted by Under Secretary of War Robert P. Patterson, described in a letter to Edward J. Brown, President of the International Brotherhood of Electrical Workers, dated 21 June 1944 (See A1 & A2). Known as the Patterson-Brown plan, these measures provided for payment to employees of round-trip transportation and subsistence, no loss of seniority rights, and a job on return to their former employers after the completion of at least 90 days' service. Provision was also made for official recognition of employers releasing men in response to the appeal (See App. A1). Thousands of people ^{were} ~~are~~ interviewed, and whenever the interview was successfully concluded, the prospective employee was supplied with necessary credentials and transportation to the job site. Security regulations were rigidly observed, and all persons employed were carefully investigated as to their past history, loyalty, habits, citizenship and other characteristics.

(3) Magnitude of the Labor Problem. - To convey some idea of the magnitude of the undertaking, in the peak month of July 1944, a total of 12,000 men were actually working on the electromagnetic project, and the average had been in the neighborhood of this figure for approximately 8 months (See App. D11). It is estimated that upwards of 400,000 people were interviewed for the entire Stone and Webster program, includ-

~~SECRET~~

ing Y-12, as for every person hired two or three others were not. This is approximately equivalent to interviewing the entire ^{1940 population} populace of Houston, Texas, which ^{was then} is the twentieth city in the United States in size. A contributing factor in the interviewing and hiring of so great a number of persons was the fact that, at that time, inductions into the armed services were at their height. However, deferments were requested for those employees whose particular skills fell in critical categories and who could not readily be replaced. In nearly all cases, such deferments were granted. Also, because of the fact that the location of the project is in a primarily rural area, a large percentage of the laborers and craftsmen, particularly the carpenters, lived on surrounding farms, and, consequently, took time off for planting and harvesting their crops.

b. Housing. - One of the most serious obstacles which had to be overcome in order to keep personnel on the project was inadequate housing. At the inception of the project, housing facilities were practically non-existent, but, as rapidly as possible, hutment camps for white and colored personnel, trailer camps equipped with Government-owned trailers or for private trailers, small family huts for supervisors and dormitories were built. A limited number of key personnel were awarded houses in the Townsite but these facilities were, in general, reserved for the operating personnel (See Book I, Volume 12).

c. Transportation. - Despite the efforts made to provide housing facilities on the area, it was necessary for many thousand^{of} employees to commute from surrounding villages, towns, and cities. Thus, the lack of transportation became a stumbling block in maintaining manpower on the job. Distances as great as 90 miles were covered twice

~~SECRET~~

daily at a time when gasoline and tires were already at a premium. However, the Personnel Department did all possible to alleviate the seriousness of the problem by establishing and operating an officially sanctioned OPA Gas and Tire Rationing Board on the area. At the peak of activities it was estimated that approximately 8,000 automobiles entered the area daily, and that about 400,000 miles were covered by these vehicles each day. Busses were operated to surrounding centers of population, at a nominal tariff. A shuttle train was operated by Stone and Webster Engineering Corporation over the L&N Railroad between Knoxville and the job site. Fifteen obsolete coaches were obtained, twelve from the Chicago, Burlington & Quincy Railroad, with a capacity of 60 passengers each, and three from the New York, Ontario & Western Railroad, with a capacity of 70 passengers each. These coaches were altered by Stone and Webster Engineering Corporation so as to increase their capacity, and from 1,000 to 1,200 passengers were carried per trip. The service was inaugurated on the morning of 4 August 1943 and discontinued with the final run on 15 July 1944 (See App. B31). Intra-area busses were also operated from the various housing facilities and trailer camps to the job site. Such busses were at first operated by Stone and Webster Engineering Corporation, but all were gradually turned over to Roane--Anderson Company by 31 August 1944 (See Bk. I, Vol. 12).

d. Recreation and Welfare. - Because of the semi-isolated nature of the project, it was necessary to provide facilities for recreation and welfare on the area. Inasmuch as these subjects are treated in detail in another Book of the History (Book I, Volume 12), suffice it to say here that, in many cases, the retention of employees

~~SECRET~~

on the job was due solely to the successful establishment and subsequent operation of these facilities.

e. Labor Relations and Stoppages. - Although it must be expected that some labor difficulties and grievances should have occurred on an undertaking of the scope of the electromagnetic project, yet, because of the efficient functioning of the Labor Relations Department of Stone and Webster Engineering Corporation, in conjunction with members of the U. S. E. D. and the business agents of the labor unions, it was possible to anticipate and compromise, or arbitrate, all disputes. Considering the fact that as many as four crafts were involved in the setting of a single piece of equipment, it reflects credit on the Labor Relations Department and the patriotism of the employees that comparatively few manhours were lost because of jurisdictional disputes or other work stoppages. (See Book I, Volume 5.)

5-2. Safety.

a. General. - The magnitude of the work to be performed in the Y-12 area at the Clinton Engineer Works was sufficient to require the organization of a complete program of safety and accident prevention. A Chief Safety Engineer was assigned to the project before any actual work was begun in the field. The parent safety organization was set up in the District Office, and, in early 1943, an inspector from that office was assigned to cover preliminary grading and construction in Y-12. A Safety Engineer was assigned to the project under the joint supervision of the Chief Safety Engineer and the Y-12 resident engineer. The personnel of the Y-12 Safety Department was increased in proportion to

[REDACTED]

the manpower of the job, and, at the peak of construction (late summer and fall, 1943), six inspectors and an engineer comprised the staff. An inspector was assigned to each construction division. Their duties were to inaugurate accident prevention programs within the divisions and to effect close inspection of all work in progress. An additional inspector was assigned to cover night operations. A similar pattern of organization was set up for the Y-12 Extension. One inspector supervised the organization for accident prevention during the early stages of construction, but the staff was increased to an engineer and four inspectors at the peak of construction (See App. D14).

b. Obligations of the Safety Department. - The safety program of the electromagnetic plant was developed from and conformed with the safety concepts of the Corps of Engineers. The duties included responsibilities uncommon to other Districts, as described in pertinent District Circular Letters. These letters were subsequently compiled in District Circular Letter (Safety 45-5) subject: Safety and Accident Prevention Program. The more important duties of the Safety Department included:

(1) Accident Reporting. - A full time investigator whose office was located at the field hospital investigated and completed all formal insurance and government reports of lost-time accidents and compensable injuries.

(2) Orientation of New Employees. - A staff member maintained quarters at the Main Personnel Office where he gave safety instructions to all new employees. He also distributed pertinent literature, printed rules, etc.

(3) Sanitation and Public Health. - A sanitary engineer made frequent inspections of all cafeterias, canteens, and drinking water facilities. He also supervised mosquito control and the sanitation of latrines.

(4) Fire Prevention Inspection. - Regular inspections were made of the area by a trained fire prevention inspector.

(5) Sterilization of Personal Protective Equipment. - A plant was established for the sterilization of goggles, respirators, gas masks, hard hats, boots, raincoats, etc. Daily pickup and delivery service was effected at all tool rooms.

(6) Motor Vehicle Inspection. - Weekly safety lane inspection was made of all motor vehicles.

c. Policies of the Department. - Many and various problems pertaining to safety arose during work on the electromagnetic plant. Policies were established in accordance with safety requirements of the Corps of Engineers to cope with these problems.

(1) Cooperation with Other Agencies. - Close contact and cooperation were maintained among the Stone and Webster Engineering Corporation safety organization and the Safety Section of U. S. E. D., the engineers assigned to the project by the insurance carrier, and the fire department and the safety department of the operating company.

(2) Meetings. - Weekly meetings of the general committee, whose members included the general superintendent, resident engineer, division superintendents, division engineers, and department heads, were called to assist general superintendents in maintaining low averages of

[REDACTED]

accident frequency and severity. The division committee meetings and foremen's meetings were called weekly to discuss current problems of safety.

(3) Publicity and Education. - Extensive use was made of safety posters, National Safety Council Safe Practices Pamphlets, material prepared by the A. E. M., and information furnished by the Corps of Engineers in making the employee safety conscious. An automobile equipped with a public address system was used to good advantage where outdoor safety meetings were held.

d. Medical Facilities. - Field first aid stations were established on the basis of one per one thousand employees up to five thousand, and one station for each two thousand employees thereafter. Serious wounds or fractures were not attended at the aid stations but were treated at the field hospital. The field hospital was first located about a mile and a half from Y-12, but in August 1943, it was moved to a new building in the Y-12 Area. Five physicians and eight registered nurses staffed the hospital during the peak construction period. Two ambulances at Y-12 provided service to Knoxville when necessary. In November 1943, the hospital in Oak Ridge was opened, and it performed practically all medical services beyond the limitations of the aid stations and the field hospital.

e. Comparative Statistics. - It may be seen from the following comparable statistics that the Safety Department performed a very commendable job:

<u>1943 Rates</u>	<u>Frequency</u>	<u>Severity</u>
Y-12 Area*	7.75	1.37
Construction Industry**	49.87	5.43



<u>1943 Rates</u>	<u>Frequency</u>	<u>Severity</u>
Corps of Engineers***	14.29	2.74
<u>1944 Rates</u>		
Y-12 Area*	7.70	2.07
Construction Industry**	23.02	2.65
Corps of Engineers***	10.51	2.50

Source:

- * Y-12 Safety Records.
- ** Accident Facts - National Safety Council, 1944-5.
- *** Office of Provost Marshall General.

f. Fatal Accidents. - Five fatal accidents occurred during the course of construction of Y-12; of these, none could be attributed to the unusual nature of the purpose of the work; one person was run over by a tractor, one was electrocuted, one was burned to death in a welding accident, and two died as the result of falls (See App. B-20).

5-3. Security.

a. Guard Force. - During January 1945, Stone and Webster was issued a directive authorizing them to process the hiring of Guard-Trainees and to place them on the Stone and Webster payroll (See App. B17). The first guard-trainee was hired 5 February 1945 and the last one was hired on 2 December 1945. A total of 1844 trainees were hired within these dates. The District Protective Security Offices approved all applications until this function was taken over by a Guard Chief. The trainees were subjected to a 3-months training and probation period after which they were transferred to Manhattan District payroll. While the guards were often identified as "Stone and Webster" guards they were assigned to and under the direction of the District Protective Security Office.



[REDACTED]

ect supervision of the District Protective Security Officer until 20 September 1943 when they became members of the Auxiliary Military Police. The guards handled traffic and manual patrols and guard posts for early construction areas. After the first fence construction started in Y-12 Area guards were placed within this area and within buildings. During October 1943, Tennessee Eastman Corporation took over the protection of Y-12 and guards were thereafter assigned by them wherever they were required on installations under construction (See App. B18).

b. Fire.

(1) General. - From the time that the first bulldozers scarified and grubbed away the sedge grass and weeds from the area of what is now Y-12, there were presented unusual fire hazards to a job which is unparalleled in all history. What was to happen beyond the start of construction could not be ascertained, since a plant designed for the manufacture of this extraordinary product, involving brand new processes, was to undergo many changes in plans while construction was in progress. Arrangements for storing all construction materials were made in such a way as to reduce to a minimum any possibility of creating destructive fires and were in keeping with standard recommendations for fire prevention. Proper types of portable fire fighting equipment were installed in the various storage yards and were supplemented by adequate numbers of large water barrels equipped with buckets. These barrels of water were protected during the winter months by the addition of anti-freeze chemicals.

(2) Water Mains. - As soon as the first building was started a temporary raw water main was laid and tapped within easy access of all work centers, and as the project grew this main was replaced by a

larger one, which served until September 1943, when the permanent mains were placed in service.

(3) Procedures. - Fire inspectors, who worked in connection with the Safety Departments, instituted by the construction contractor and the United States Engineer Department, were very active in promoting all principles and devices for the removal of conditions favorable to fires. Many memoranda and posters were issued and placed in conspicuous places, calling everyone's attention to the necessary precautions which must be taken to make all areas free from costly fires. Safety meetings, regularly attended by division superintendents, engineers, supervisors, foreman, and craftsmen, included discussions relative to the promotion of better practices in construction methods for the purpose of eliminating fires. Trained fire fighters attended these meetings at regular intervals to acquaint the men with the various types of portable fire fighting equipment. Demonstrations of the merits and effectiveness of the various types of equipment were made on test fires to further acquaint the workmen with their uses.

(4) Hazards from Welding. - Fires, that were frequently started but controlled, were in most cases attributed to electric and gas methods of welding and cutting steel. All workmen who used electric and gas methods of welding were thoroughly instructed as to how an area should be cleared of all combustibles before their equipment was used.

(5) Material Storage Practice. - After materials had served their purpose in construction, they were well stacked in adjacent areas which had been properly cleared and could be protected from fire by temporary means. Good methods, practices, and an orderly arrangement of

[REDACTED]

materials in those classification yards kept down fire hazards and facilitated the reuse of materials elsewhere. Equipment of the types previously mentioned in this report was used in protecting these yards from fires.

(6) Damage by Fire. - Extensive fires representing losses of \$10,000 at a Steel Plate Shop on June 13, 1944 and damage amounting to \$3,000 at the Steel Prefabrication Shop on September 7, 1944 were the only occurrences of major fires in this area. There were no deaths or serious injuries attributed to fire in the Y-12 Area other than that mentioned in paragraph 5-2f (See App. B19).

(7) Firemen-trainees. - In January 1943, Stone and Webster was authorized by the District Engineer to hire and process fireman-trainees (See App. B17). During the period of 12 February 1943 to 1 December 1943 a total of 328 men had been hired. Equipment and firemen were stationed at the Y-12 Area and were under the control of Stone and Webster. After October 1943 all fire protection for Y-12 was taken over by Tennessee Eastman Corporation.

c. Intelligence and Security.

(1) Clearance for Restricted Area. - Military Intelligence required a Personnel Security Questionnaire to be made out for each employee of the construction contractor before he could enter a restricted area or handle classified documents. They then reviewed the completed form for clearance. Some forms were further distributed to a commercial company or to a Government agency for investigation. About 72,890 questionnaires were reviewed between 16 February 1943 and 1 July 1945. Of these, 932 were for naturalized citizens and contained complete information concerning the naturalization records. In addition, 75 alien questionnaires have been reviewed for a few who have been employed within Y-12 or Y-12

[REDACTED]

Extension by subcontractors.

(2) Fingerprints. - All fingerprints of employees were transmitted to the Federal Bureau of Investigation through the Military Intelligence Division. If a record was on file it was returned through Military Intelligence to the Stone and Webster Personnel Section, to be compared with the arrest record given by the employee at the time he was hired. About 21,000 arrest records were given by applicants at the time of hiring, the vast majority being voluntary information about traffic offenses or drunkenness. If the employee failed to state his arrest record when he was hired, or failed to give a complete record on serious charges, if still employed he was contacted and interviewed. He was either retained or discharged, as judged by his attitude towards being questioned, the seriousness of his arrest, his work and absenteeism record, and the urgent need of his classification of work. Many were discharged for falsifying the most serious arrests, many were retained. Of those retained, most were allowed only in the general area, and not in the restricted areas. No one was hired or retained that had been convicted of a rape, arson, or narcotic charge.

(3) Badges and Passes. - A number of different methods were devised to identify an individual's clearance to a multitude of restricted areas requiring specific clearance. A general clearance method used was the issuance of badges with various colored backgrounds. These were used for clearance to general areas, such as Y-12 and Y-12 Extension. Pass cards of different color schemes were issued for restricted areas in Y-12. Over 8,694 cards were issued to construction forces for eleven Y-12 restricted areas. Badges were issued in place of pass cards in Y-12 Extension.

~~SECRET~~

sion with letters denoting restricted areas for which personnel were cleared. For the period between 15 April 1944 through 31 October 1944, 10,150 badges of this type were issued. The same procedures were followed for the employees of Stone and Webster contractors.

(4) Personnel Investigation. - The large number of employees who were never previously investigated necessitated extensive investigation by mail. Stone and Webster, at the request of Military Intelligence, was asked to conduct a part of this investigation for employees active on their payroll. A vast number of letters were sent to former employees, friends, etc. and 75% of these were answered. A large percentage not answered were a result of wrong addresses. As a further means of security, a file of 6,000 cards was kept containing derogatory information on employees from other jobs. Over 4,090 "stop cards" were furnished by Military Intelligence to protect against the hiring of undesirable applicants. In addition, 1,164 "no pass" cards were kept to guard against issuing passes to personnel barred from this area.

~~SECRET~~

~~SECRET~~

SECTION 6 - ORGANIZATION AND PERSONNEL

6-1. Manhattan District. - Construction at the Electromagnetic Plant performed under Stone and Webster Engineering Corporation's management was supervised for the Manhattan District by the Y-12 Construction Officer, who was responsible, through the Y-12 Unit Chief, to the District Engineer, Col. K. D. Nichols. Prior to January 1945, the construction officer was directly responsible to the District Engineer, and the Y-12 Unit Chief assisted the District Engineer in coordinating the design and operation phases of the program with construction. The operating contractor, Tennessee Eastman Corporation, assisted in the final inspection and recommended that the facilities be accepted as they were completed, for operation by the Government.

The following officers were connected with this work during the periods indicated:

Lt. Col. Warren George, as Construction Officer, was responsible for all construction at Y-12 from November 1943 to January 1944, during which time he was assisted by Major Roy C. Blackledge. From January 1944 to May 1944 Col. John S. Hodgson was the Construction Officer at Y-12. Lt. Col. M. C. Fox, (November 1943 to June 1944) was assigned as assistant in charge of construction at Y-12 Extension. Col. Walter Williams was assigned as Assistant Construction Officer in January 1944 and served as Construction Officer from May 1944 to 1 January 1945 at which time he was succeeded by his assistant, Major L. E. Johnston, who served until 23 January 1945. On 23 January 1945, Lt. Col. L. W. Kehe assumed the responsibilities of the Y-12 Construction Officer, until he was succeeded in June 1945 by Lt. Col. M. C. Fox, who remained on active duty as

~~SECRET~~

[REDACTED]

15 May 1946

Construction Officer until ~~December 1945~~, when the active duties were assumed by Major Kenneth A. Dunbar. Major Dunbar continued as Construction Officer at the electromagnetic plant until after the project was taken over 1 January 1947 by the Atomic Energy Commission. Capt. A. O. Garvik served as Assistant Construction Officer from January 1945 until June 1946. Major W. E. Kelley was assigned as Y-12 Unit Chief from March 1943 to September 1944, when he was succeeded by Lt. Col. J. R. Ruhoff, who in turn was succeeded in November 1945 by Col. G. J. Forney. Colonel Forney continued to serve as Y-12 Unit Chief until after the project was taken over on 1 January ¹⁹⁴⁷ by the Atomic Energy Commission.

6-2. Stone and Webster Engineering Corporation. - The entire activities of Stone and Webster Engineering Corporation in the development and construction of the Clinton Engineer Works came under the direct management of Mr. R. I. Branch, President. Key personnel, assigned from the Stone and Webster Organization to devote their entire time to the design, engineering, purchasing and expediting of all requirements, were moved to separate headquarters and acted as managers and department heads, under the supervision of Mr. A. C. Klein, Project Engineer. This nucleus was supplemented by the employment of additional personnel.

A smaller organization under the direction of Mr. R. R. Wisner, Assistant Project Engineer, was employed at the area, working in close cooperation with the Boston Office. Still another group was assembled at Berkeley, California, doing research work, headed by Mr. L. O. Waite and Mr. R. E. Argersinger.

The field construction ^{organization} was formed from Stone and Webster employees of long standing, and was assembled under the direction of the Project

[REDACTED]

Manager, Mr. T. C. Williams. This personnel consisted of General Superintendents, Chief Field Accountant, Resident Engineers, Purchasing Agent, Personnel Manager, Process Engineer, Chief Expeditor and Division Superintendents, with their sub-organizations, which varied in size in accordance with construction activities (See App. D10). The following list of key personnel indicates the length of service of each at this project, together with a brief description of his classification:

<u>Name</u>	<u>Started</u>	<u>Terminated</u>	<u>Classification</u>
R. T. Branch	6-29-42		President-District Manager
A. C. Klein	6-29-42		Project Engineer
F. R. Creedon	1-6-44	1-31-45	Resident Manager
T. C. Williams	6-29-42	5-13-44	Project Manager
A. L. Hartridge	7-26-43	6-10-44	Asst. Project Manager
T. B. Thornburg	3-17-43	1-17-45	General Superintendent-Y-12 Area
T. B. Thornburg	1-31-45		Project Manager
H. F. Cleary	2-27-43		General Superintendent Y-12 Extension
R. R. Wisner	6-29-42		Asst. Project Engineer
E.W. Seckendorff	7-7-43		Process Engineer
G.P. Darlington	6-29-43		Chief Expeditor
E.P. O'Connor	11-15-42		Chief Field Accountant
T. W. Piper	12-26-42		Personnel Manager
J. P. Piper	12-1-42		Purchasing Agent
G. E. Crosby	4-15-43		Administrative Engineer
Paul Brown	11-2-42	6-23-45	Y-12 Resident Engineer

<u>Name</u>	<u>Started</u>	<u>Terminated</u>	<u>Classification</u>
E. L. Field	7-1-44	2-2-45	Division Superintendent
E.L. Field	2-2-45		General Superintendent
Frank Wells	5-10-45		Electrical Superintendent
A.P. Nicholson	3-15-43		Mechanical Superintendent
Luther Thompson	11-2-42		Carpenter Superintendent
H. J. Sykes	5-3-43		Asst. Genl. Superintendant
G. D. Brown	3-11-43		Division Superintendent
J. S. Howley	3-24-43	6-20-45	Division Superintendent
C.J. Baldwin	3-22-43		Piping Superintendent
W. B. Stansbury	5-18-43	9-2-44	Division Superintendent
J. L. Cannon	4-17-43		Division Superintendent
E.L. Maier	3-31-43	6-30-45	Division Superintendent
W.L. Sheets	11-8-43	6-23-45	Y-12 Ext. Res. Engineer
L.W. Wilkes	12-1-43		Mechanical Superintendent
E.E. Jones	8-16-43		Electrical Superintendent
W. L. Pitzer	6-11-43		Division Superintendent
J. D. Butterfield	12-28-43	9-20-44	Division Superintendent
H. R. MacPhee	12-1-42	9-30-44	Rigging Superintendent
Myron Groht	9-10-43		Night Superintendent
Harry Thompson	7-6-43	6-30-45	Night Superintendent
Glenn Fulcher	1-18-44		Rigging Superintendent
William Fisher	11-5-43		Electrical Superintendent
H.M. McCampbell	9-6-43	9-8-44	Asst. Gen. Superintendent

6-3. Acknowledgement of Assistance.

[REDACTED]

a. Magnet Coil Construction. - Several conferences were arranged to discuss corrective measures to overcome the difficulties experienced with low resistance in the coils of the first Alpha Track. At these conferences Messrs. F. I. Marvel, Brand and E. A. Elge of General Electric Company, Dr. C.F. Hill and Mr. J.G. Ford of Westinghouse Electric and Mfg. Company, and Messrs. K.P. ^{Wiedehecker} Wiedekehr and Sealy of Allis-Chalmers Company were present in a consulting capacity to discuss improvements in coil construction (See Paragraph 3-7, b). Dr. Miller of the Standard Oil Company was requested to investigate and recommend suitable treatment of the oil. Mr. H.R. Young of E. I. duPont de Nemours and Company, assisted in determining the proper materials to use for treating internal pipe surfaces. (See App. B10).

b. Distilled Water System. - The firm of Sheppard T. Powell was consulted on the major problem of supplying distilled water to the process equipment.

c. Installation Procedures. - The field forces received much valuable assistance from engineers and physicists from the Radiation Laboratory at the University of California. These men were helpful in conveying suggestions on methods of installation and testing, particularly on the high vacuum system. The construction forces were also assisted by competent service engineers furnished by the several companies supplying special equipment.

~~SECRET~~

MANHATTAN DISTRICT HISTORY
BOOK V - ELECTROMAGNETIC PROJECT
VOLUME 5 - CONSTRUCTION

APPENDIX "A"

DOCUMENTS

No.

Description

1. Letter (with enclosure) from Under Secretary of War, Robert P. Patterson to Mr. E. J. Brown, President of I.B.E.W., dated 21 June 1944.
2. Letter of Appeal to Electrical Workers from Mr. E. J. Brown, dated 23 June 1944.

~~SECRET~~

C
O
P
Y

WAR DEPARTMENT

Washington, D. C.

June 21, 1

Mr. Edward J. Brown, President,
International Brotherhood of Electrical Workers,
1200 15th Street, N. W.
Washington, D. C.

Dear Sir:

A critical shortage of skilled electrical workers is seriously hampering construction of two different but equally vital War Department "must" projects, the Hanford Engineer Works Pasco, Washington, and the Clinton Engineer Works, Knoxville, Tennessee.

The shortage of electrical workers on each of these projects has become so critical that extraordinary measures must be taken to place men on these jobs. Ordinary no method as well as some extraordinary measures never failed to adequately staff the jobs. Full advantage has been taken of the facilities of the War Manpower Commission. Conferences with your organization, the National Electrical Contractors' Association, and the War Manpower Commission indicate that the most feasible, as yet untried, plan to meet this emergency is to call for volunteers to serve on these projects for a period of at least 90 days. A statement outlining this plan is enclosed.

I am certain that a vigorous prosecution of this program will successfully man these vital projects and that such a vigorous prosecution can only be insured if you give it your promised, whole-hearted support.

Sincerely yours,

(Signed) Robert P. Patterson

ROBERT P. PATTERSON,
Under Secretary of War.

1 Encl.
Statement

~~SECRET~~

[REDACTED] [REDACTED]

rate is \$1.65 per hour with total earnings of \$100.65 for the standard 54-hour week. At the Clinton Engineer Works the wage rate is \$1.50 per hour with total earnings of \$105.00 per week for the standard 60-hour week. Housing in dormitories and food in mess halls are furnished at the Hanford Engineer Works for a flat charge of \$14.00 per week. At the Clinton Engineer Works the charge for dormitory rooms run from \$12.00 to \$15.00 per month, depending on the type provided, and food is served in cafeterias at charges averaging \$8.75 to \$12.00 per week.

The housing and food at both projects is excellent. Union officials and others who have inspected the projects state that living conditions are the best they have encountered on construction projects.

Round trip rail transportation plus a subsistence allowance of \$2.50 per day while in travel will be furnished all men volunteering under this plan. In each case, the local union of the International Brotherhood of Electrical Workers will furnish a rail coach ticket and money for subsistence to men leaving for the projects. The local union will be reimbursed immediately by a contractor who employs the men.

Contractors who will hire electrical workers under this plan are Berry, Chandler and Lord at Hanford Engineer Works and Watson-Flagg and Atcock-Bryant at Clinton Engineer Works.

An office to coordinate the program has been established in the War Department, Office, Chief of Engineers, in Washington. Mr. Arlie Dicke is in charge of the office and will be available to answer any questions in connection with the program. Mr. Dicke may be reached by telephone in Washington Republic 5700, Extension 73654 or 73614.

[REDACTED]

[REDACTED]

[REDACTED]

SECRET

INTERNATIONAL BROTHERHOOD
ELECTRICAL WORKERS
1200 Fifteenth Street N. W.
Washington, 5 D. C.

June 23, 1944

TO I. B. E. W.
LOCAL UNIONS

Dear Sirs and brothers:

This is an appeal with a "must" to the members of various Local Unions. At the present time there is a shortage of electrical mechanics on two very important war projects, namely, the Hanford Engineering Works, Pasco, Washington, and the Clinton Engineering Works at Knoxville, Tennessee.

While both these projects have been under construction for considerable time they are far from completed; the Invasion having now become a reality, vital materials to the further prosecution of the war are very essential.

The officers of the International are appealing to our members to give of their service at this time on the two above named vital projects. We can realize that it is a burden for some of our members to leave their homes and assist in this work, however, we know of the grave consequences and the additional casualties that may be incurred by our failure to see that facilities are created wherein vital materials will be produced.

We are enclosing a personal appeal, together with a circular, from the Honorable Robert P. Patterson, the Under Secretary of War. We hope that our Local Unions and their membership will read these carefully, after which they will volunteer for the ninety-day period as specified therein. You will note that a certificate of service is to be issued to our members so volunteering. This, we believe, shows the necessity of your assistance at this time.

We are asking our local unions to gather groups of men and notify this office how many they are sending from their particular community and to which job. This will enable us to have an adequate check on the manpower available and prevent an over supply of men.

We are again appealing in the hope that our men will volunteer their services to help these most needed war projects.

Fraternally yours,

Ed J. Brown
International President

G. N. Bugnisset
International Secretary

This document contains information affecting the national defense within the meaning of the espionage laws, the transmission or the revelation of its contents in any manner to an unauthorized person is prohibited by law.

MANHATTAN DISTRICT HISTORY
BOOK V - ELECTROMAGNETIC PROJECT
VOLUME 5 - CONSTRUCTION

APPENDIX "B"

REFERENCES

<u>No.</u>	<u>Description</u>	<u>Location</u>
1	Letter from Mr. R. T. Branch to Col. J. C. Marshall regarding estimated costs - 24 September 1942	Manhattan District Classified Files
2	Stone & Webster Cost Estimate - 29 June 1943	Manhattan District Classified Files
3	Y-12 Unit Chief's Report - March 1943	Manhattan District Classified Files
4	Stone & Webster Engineering Corporation Contract No. W-7401-eng-13	Manhattan District Contract Section
5	Stone & Webster Engineering Corporation Contract No. W-14-108-eng-49	Manhattan District Contract Section
6	Stone & Webster Engineering Corporation Contract No. W-14-108-eng-60	Manhattan District Contract Section
7	Stone & Webster Report on 9201-3 Foundations	Manhattan District Classified Files
8	Stone & Webster's Bills of Material	Stone & Webster Engineering File
9	P.E. 1115 Subject - Test and Design Improvements for 2 Coils dated 21 January 1944	Manhattan District Classified Files
10	Letter from Mr. A. C. Klein to Boston Area Engineer, dated 6 August 1945	Manhattan District Classified Files
11	Memo to All CPFF Contractors from the District Engineer, dated 29 June 1945	Stone & Webster Engineering File

<u>No.</u>	<u>Description</u>	<u>Location</u>
12	Stone & Webster Engineering Corporation Cancelled Vouchers	Stone & Webster Acct. Dept. Files
13	Stone & Webster's Records of Transmittal of Fingerprints	Stone & Webster Personnel Department
14	Stone & Webster Engineering Corporation Personnel Records	Stone & Webster Personnel Department
15	Stone & Webster Report of Contracts plus Daily Commitment Records of Boston and Local Purchasing Department	Stone & Webster Acct. Department Files
16	Stone & Webster Subproject No. 47	Manhattan District Classified Files
17	Letter dated 25 January 1943, from Major Warren George to Mr. T. G. Williams	Manhattan District Classified Files
18	Tennessee Eastman Corporation Y-12 History, Vol. I	Manhattan District Classified Files
19	Tennessee Eastman Corporation Fire Department Records	Tennessee Eastman Corres. Files
20	Stone & Webster Engineering Corporation Safety Records	Stone & Webster Engineering File
21	Stone & Webster Progress Reports (File No. 600.914)	Manhattan District Classified Files
22	Report of Failure and Correction of Distilled cooling System on XAX	Manhattan District Classified Files
23	Letter from Mr. A. C. Klein, date 1 January 1944	Manhattan District Classified Files
24	PE 1177 dated January 1944, Subject - Filtering Sedimentation of Foreign Material and Removal of Water from cooling oil	Manhattan District Classified Files
25	Y-12 Unit Chief's Report, February 1944	Manhattan District Classified Files

<u>No.</u>	<u>Description</u>	<u>Location</u>
26	Letter from Mr. A. C. Klein to Mr. T. R. Thornburg - Subject: Sub-Anchorage of Alpha Bins - dated 17 November 1943	Manhattan District Classified Files
27	Tennessee Eastman Corporation Report	TEC Files
28	WA 101, Subject - Bituminous Road Surfacing	Manhattan District Classified Files
29	Stone & Webster Subproject No. 55	Manhattan District Classified Files
30	Description of Special Construction Equipment - SWK 14713 -29 January 1946	Manhattan District Classified Files
31	Stone & Webster Engineering Corporation L&N Railroad Records	Stone & Webster Engineering File

[REDACTED]

MANHATTAN DISTRICT HISTORY
BOOK V - ELECTROMAGNETIC PROJECT
VOLUME 5 - CONSTRUCTION

APPENDIX "C"

PHOTOGRAPHS

<u>No.</u>	<u>Description</u>
1	Foundation Excavation for Alpha Chemistry Building 9202 - 20 February 1943.
2	Foundation Excavation for Alpha Process Building 9201-2 - 16 April 1943.
3	Excavation and Construction of footings for Alpha Process Building 9201-1 - 16 April 1943.
4	Concrete Batching Plant - 26 April 1943.
5	Foundation Work for Development Building 9731 27 April 1943.
6	Stone & Webster Engineering Corporation Administration Building - 27 April 1943.
7	Y-12 Administration Building - 27 April 1943.
8	Foundation for Alpha Racetrack No. 1 in Building 9201-1 18 May 1943.
9	Foundation Work for the Second Alpha Building 9201-2 18 May 1943.
10	Foundation Excavation for Alpha Building 9201-3 18 May 1943.
11	Reinforced Concrete Framing for Alpha Chemistry Building 9202 - 18 May 1943.
12	Beta Chemistry Building 9203 - 18 May 1943.
13	Development Building 9731 - 22 May 1943.
14	Alpha Building 9201-1 - 2 June 1943.

[REDACTED]

SECRET

[REDACTED]

<u>No.</u>	<u>Description</u>
15	Boiler House and Beta Chemistry Building on 8 June 1943.
16	Development Building 9731, 8 June 1943.
17	Experimental Racetrack (XAX) - Building No. 9731.
18	Alpha Chemistry Building 9202 - November 1943.
19	Y-12 Plant - December 1943.
20	Completed Alpha I Racetrack.
21	Y-12 Plant - March 1944.
22	Construction of Beta Chemistry Building 9206 - May 1944.
23	Alpha II Process Building 9201-4 under construction January 1944.
24	Pump House and Cooling Tower - 24 February 1944.
25	The Second Boiler House 9401-2 under construction 24 February 1944.
26	Alpha II Process Building 9201-4 - 24 February 1944.
27	Beta Process Building 9204-2 - 24 February 1944.
28	Y-12 Plant - March 1944.
29	Y-12 Extension - March 1944.
30	Beta Process Building 9204-2 - March 1944.
31	Alpha II Process Building 9201-4 - March 1944.
32	Alpha II Racetrack Installed.
33	Panoramic View of the Y-12 Plant March 1944.
34	Beta Process Building 9204-2 - 19 April 1944.
35	Aerial View of Midway Storage Area, 22 May 1944.
36	Aerial View of Y-12 Extension - June 1944.

[REDACTED]

[REDACTED]

<u>No.</u>	<u>Description</u>
37	Aerial View of Y-12 Extension - June 1944.
38	Alpha II Drydock?
39	Y-12 Plant, September 1944.
40	Beta Process Building 9204-3 September 1944.
41	Typical Beta Racetrack Installation
42	Alpha Chemistry Building 9202 - September 1944.
43	Construction of Extension to Boiler House 9401-1 September 1944.
44	Construction of 9207 Group of Alpha Chemistry Buildings - September 1944.
45	Third Beta Process Building 9204-3 - December 1944.
46	Alpha Chemistry Building 9202 - December 1944.
47	Alpha Chemistry Building 9207 - December 1944.
48	Some Plant Auxiliaries - March 1945.
49	9207 Chemistry Group - March 1945.
50	Foundation and Partial Steel Frame for Final Product Building (9212) - June 1945.
51	Aerial View of Y-12 Plant - March 1945.
52	Aerial View of Y-12 Plant - March 1945.

[REDACTED]

01. Foundation Excavation for Alpha Chemistry

Building 9202, 20 February 1943.

This photograph shows some of the earliest work done at the Y-12 Plant.



02. Foundation Excavation for Alpha Process

Building 9201-2, 16 April 1943.



C3. Excavation and Construction of Footings
for Alpha Process Building, 9201-1, 16 April
1943.

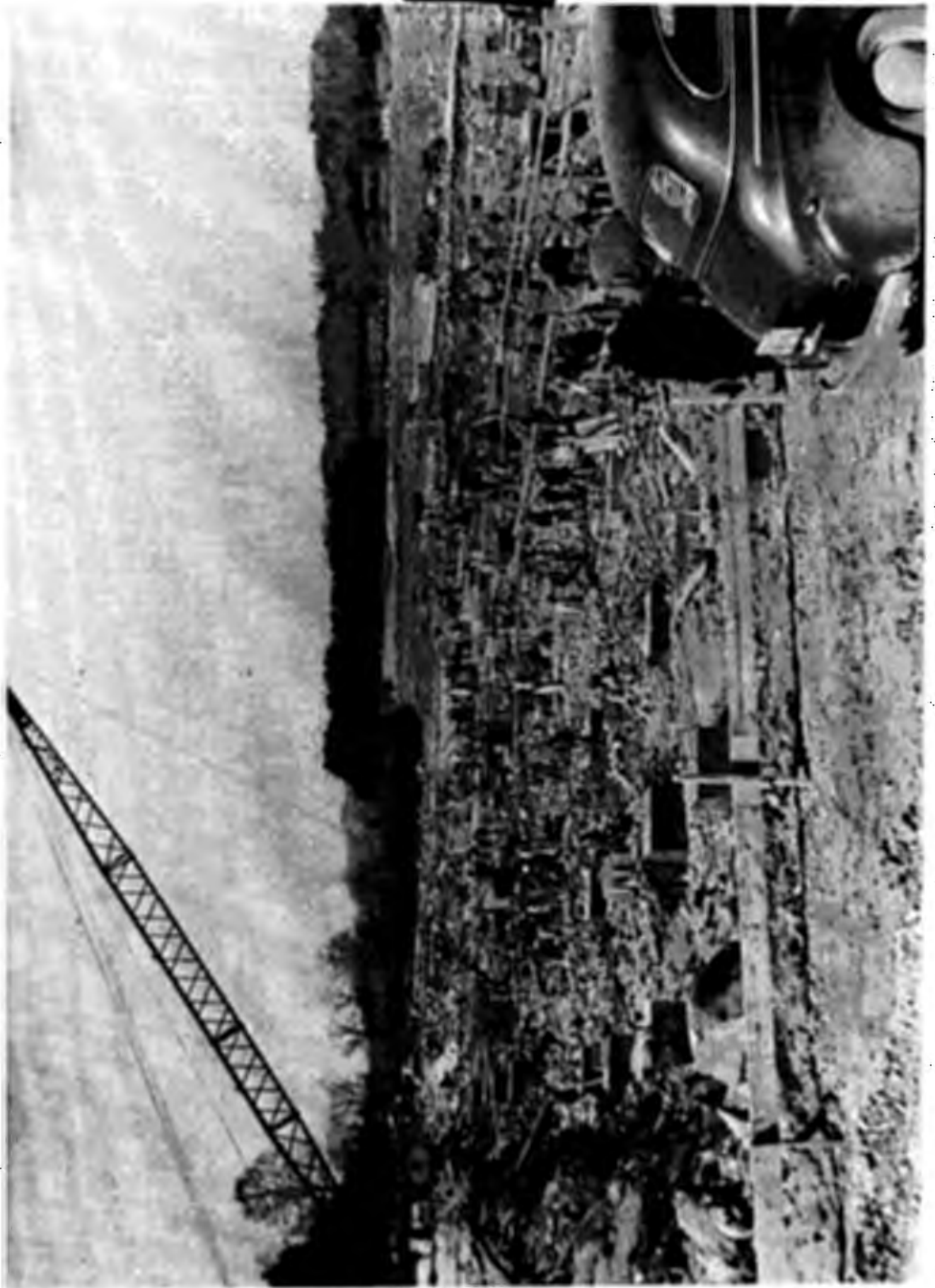

04. Concrete Batching Plant, 26 April 1943.

Concrete for Y-12 Construction was obtained from this plant, located immediately East of the Y-12 Area. In the foreground are the Time Offices and the Clock Alley for construction workers.

2000
1999
1998
1997
1996
1995
1994
1993
1992
1991
1990
1989
1988
1987
1986
1985
1984
1983
1982
1981
1980
1979
1978
1977
1976
1975
1974
1973
1972
1971
1970
1969
1968
1967
1966
1965
1964
1963
1962
1961
1960
1959
1958
1957
1956
1955
1954
1953
1952
1951
1950
1949
1948
1947
1946
1945
1944
1943
1942
1941
1940
1939
1938
1937
1936
1935
1934
1933
1932
1931
1930
1929
1928
1927
1926
1925
1924
1923
1922
1921
1920
1919
1918
1917
1916
1915
1914
1913
1912
1911
1910
1909
1908
1907
1906
1905
1904
1903
1902
1901
1900

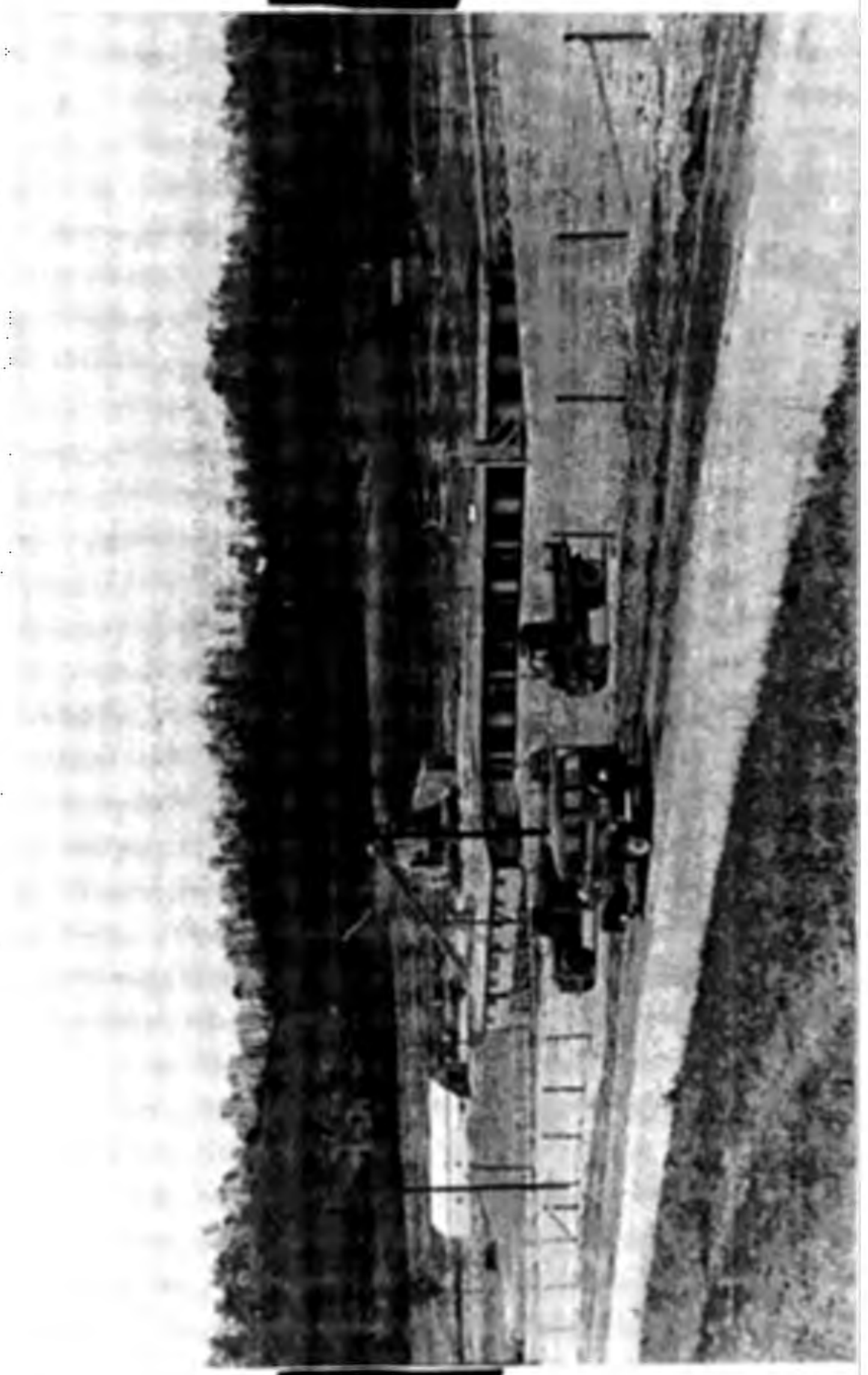

05. Foundation Work for Development Building

9731, 27 April 1943.



C6. Stone & Webster Engineering Corporation

Administration Building, 27 April 1943.

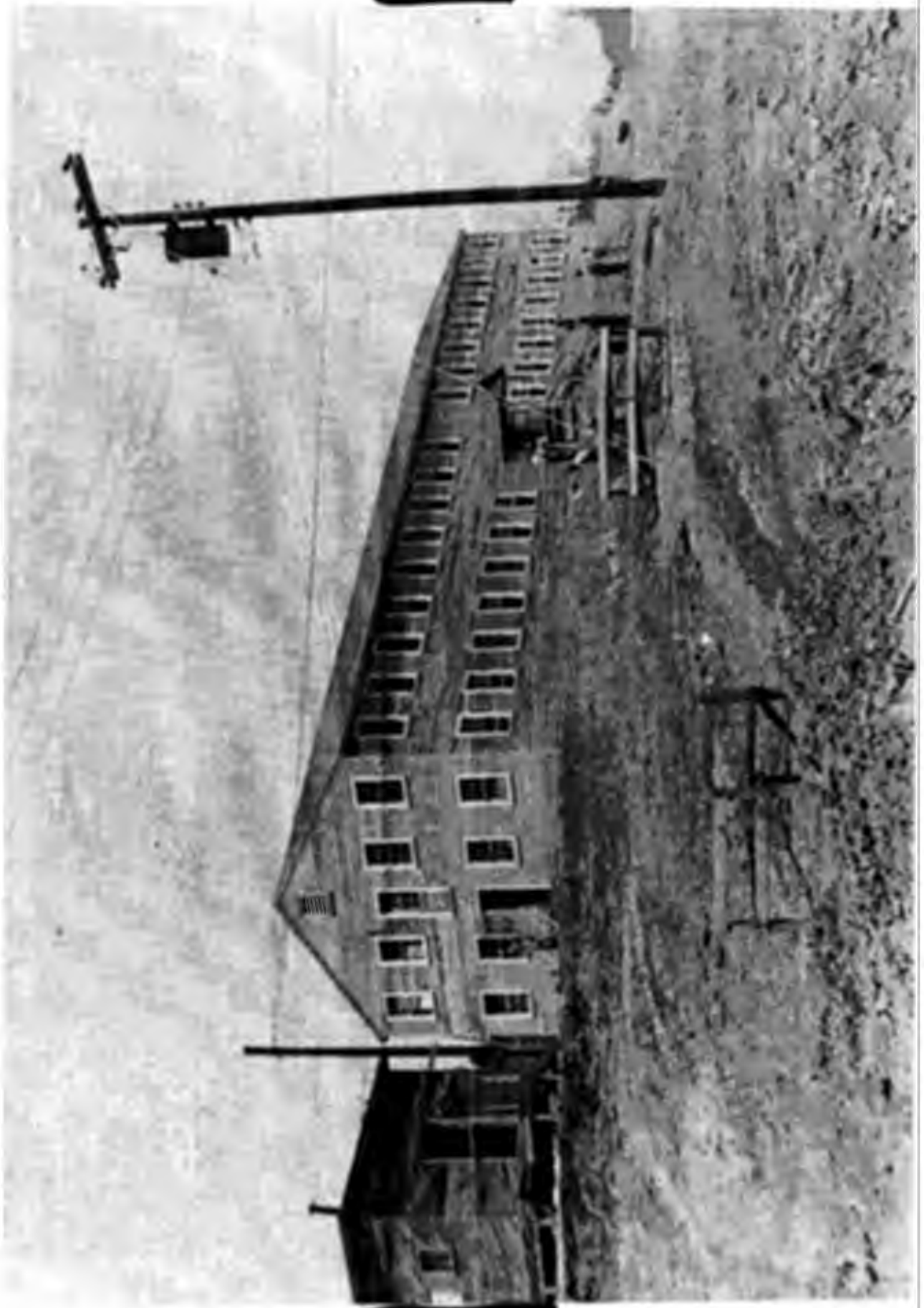

67. Y-12 Administration Building, 27 April

1945.

This building became known as the "Fish Bowl" because of glass interior partitions.

[REDACTED]

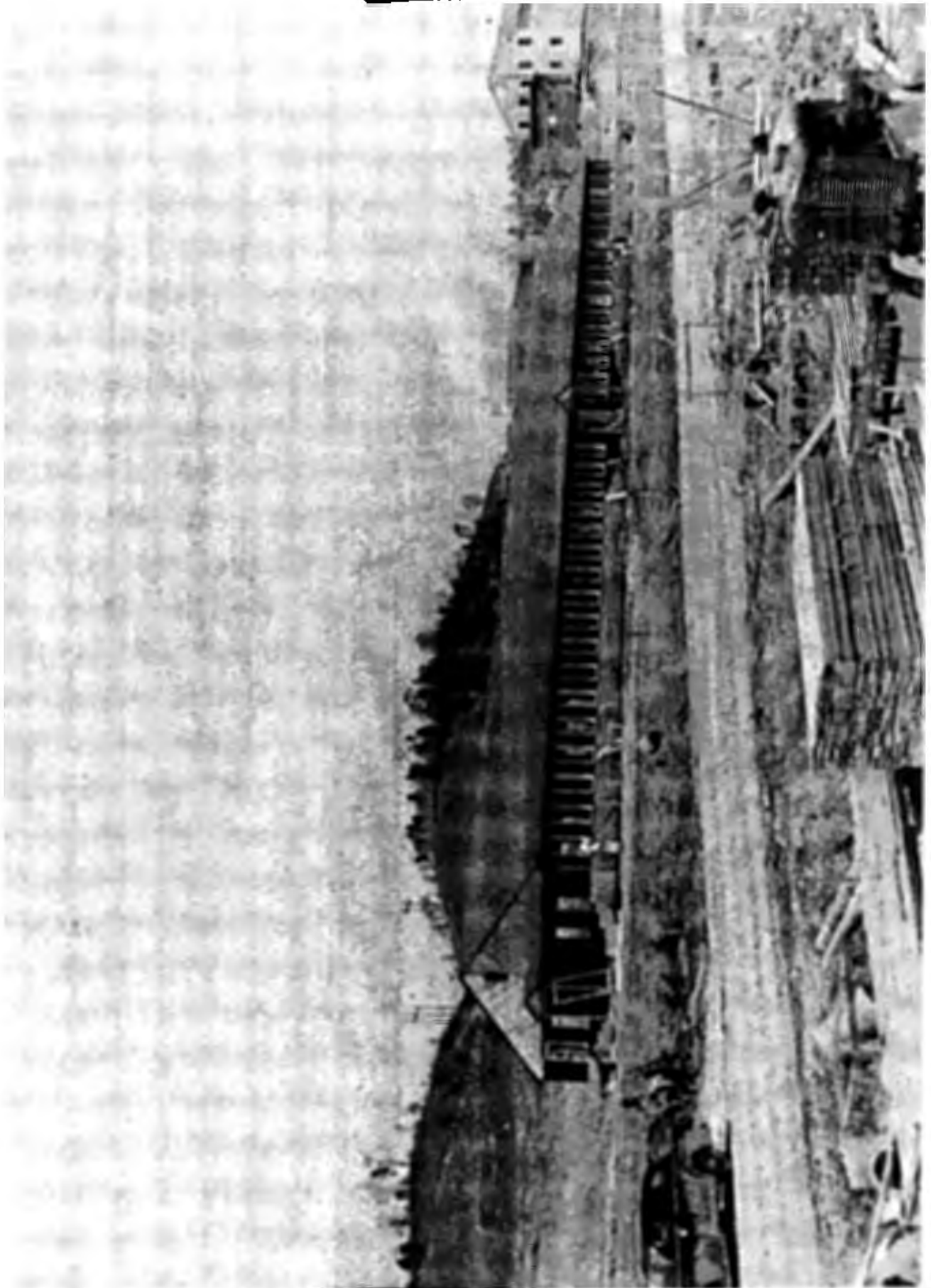

[REDACTED]

08. Foundation for Alpha Racetrack No. 1

In Building 9201-1, 18 May 1943.

The oval shape of the racetrack accounts for the arrangement of reinforcing steel shown here.

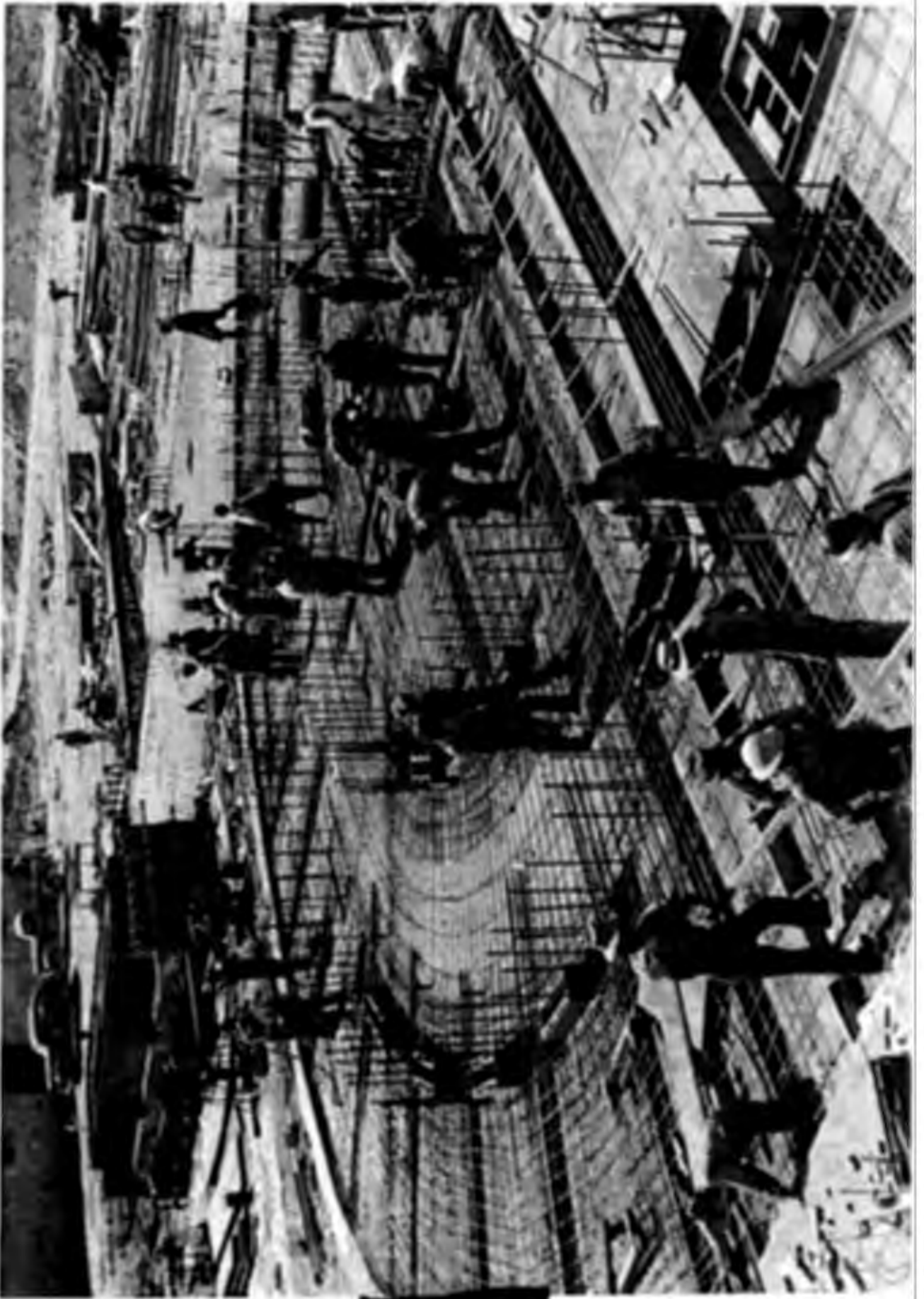

09. Foundation Work For The Second Alpha

Building 9201-2, 18 May 1943.

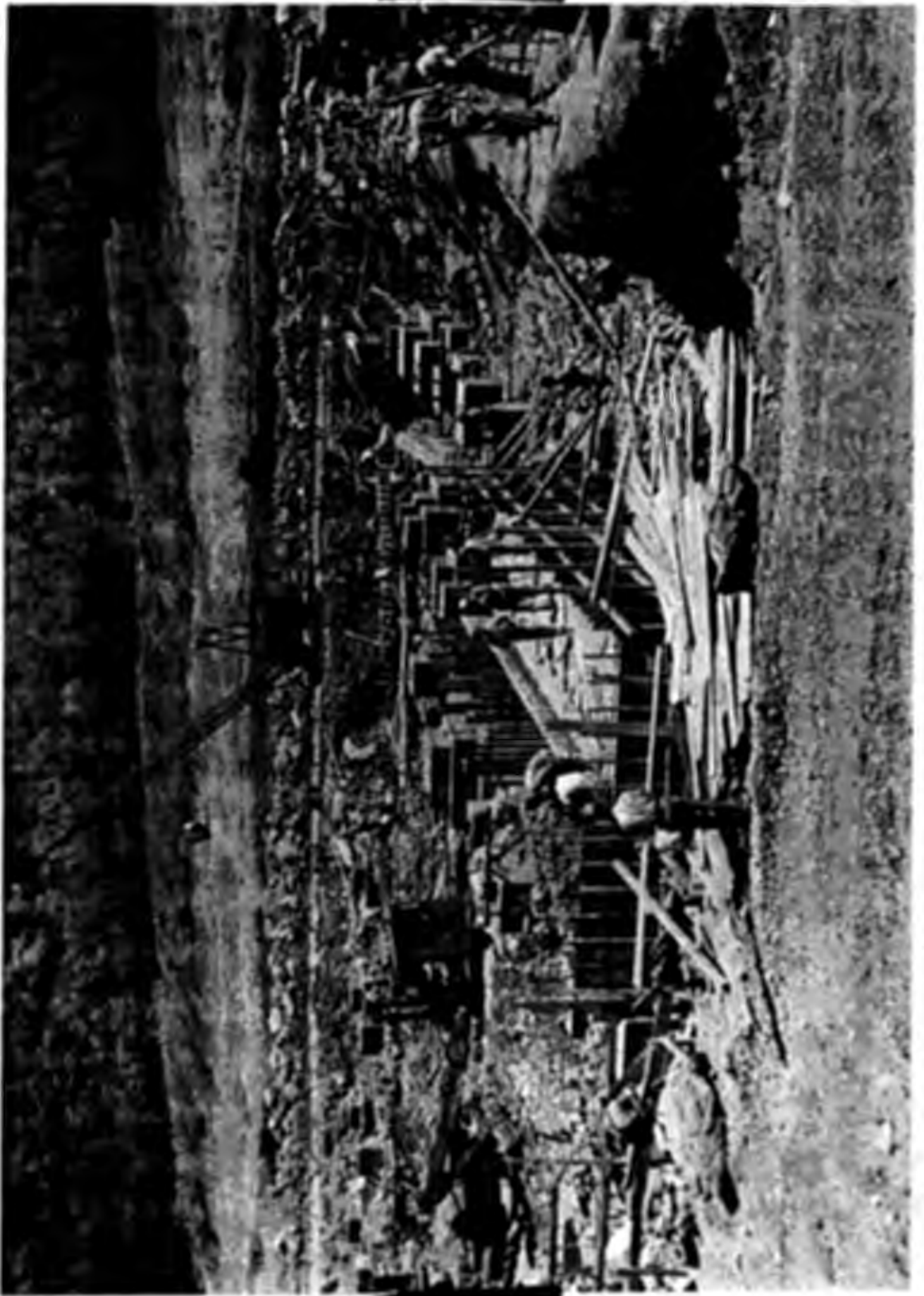

C10 Foundation Excavation For Alpha Building

9201-3, 18 May 1943.

It was here that the constructors encountered the worst foundation condition of the entire project.

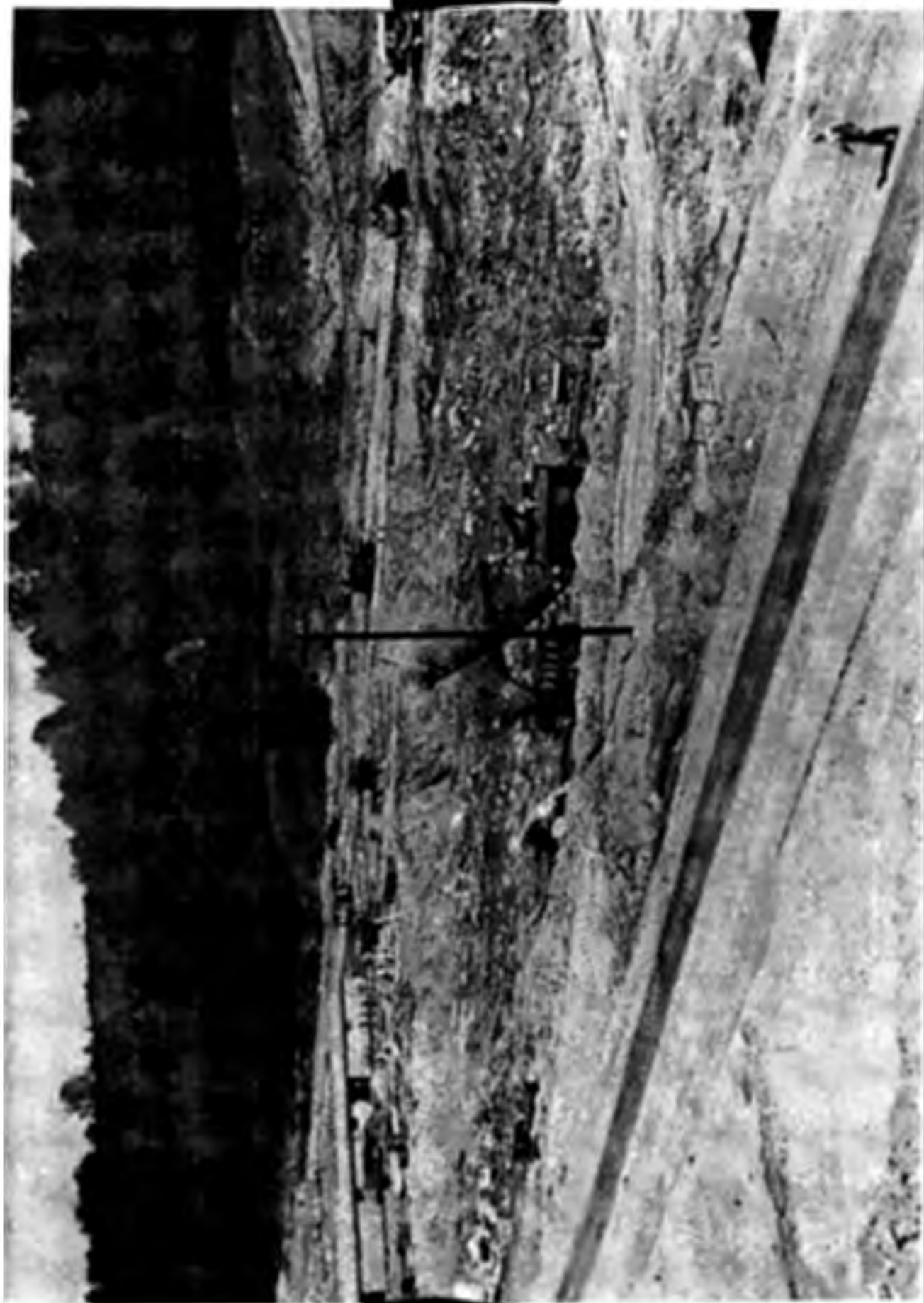

011. Reinforced Concrete Framings for Alpha
Chemistry Building 9202. 18 May 1941.

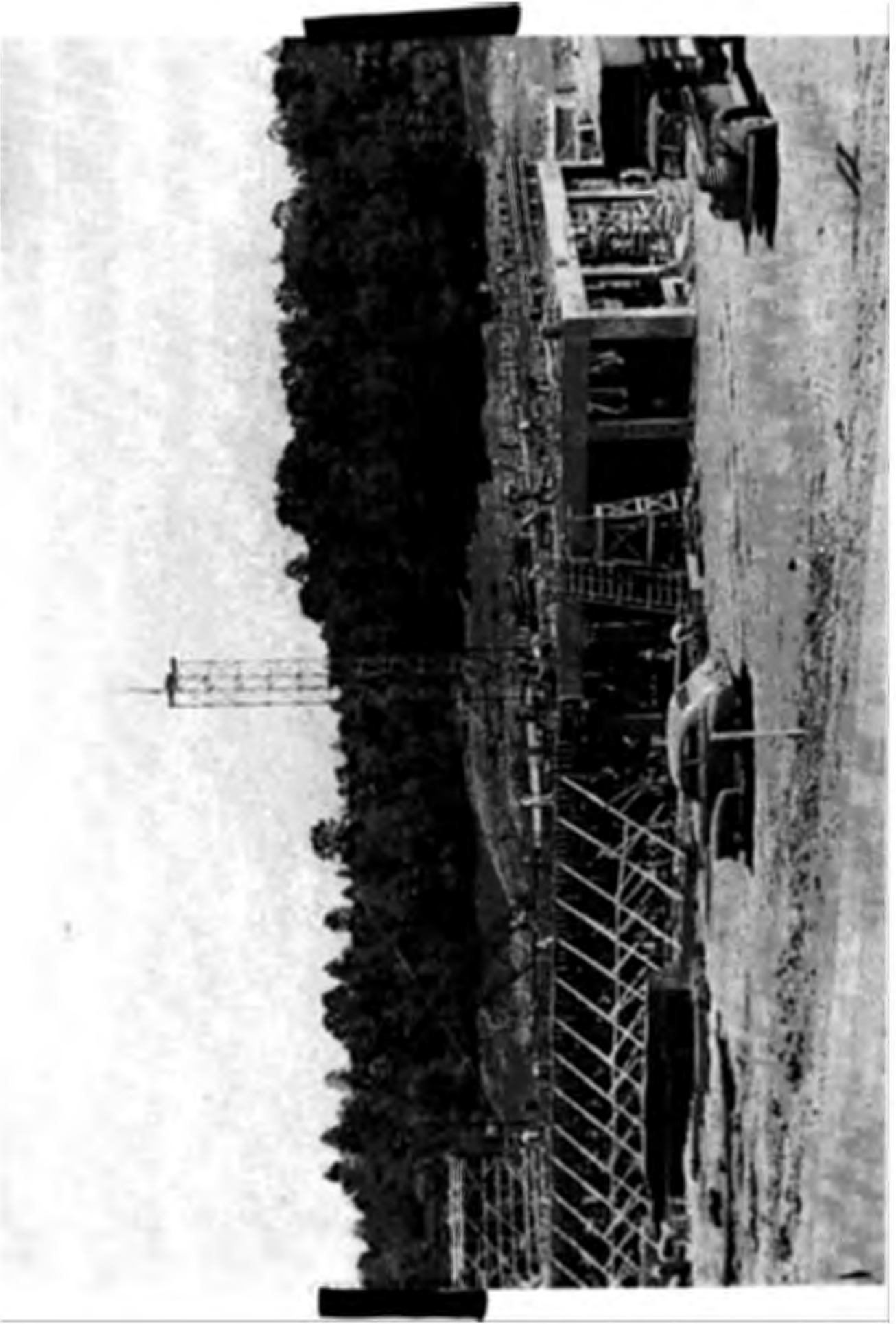

012. Beta Chemistry Building 9203, 18 May

1943.

In the background may be seen the beginning of
the brick stack and the walls for Boiler House
9401.

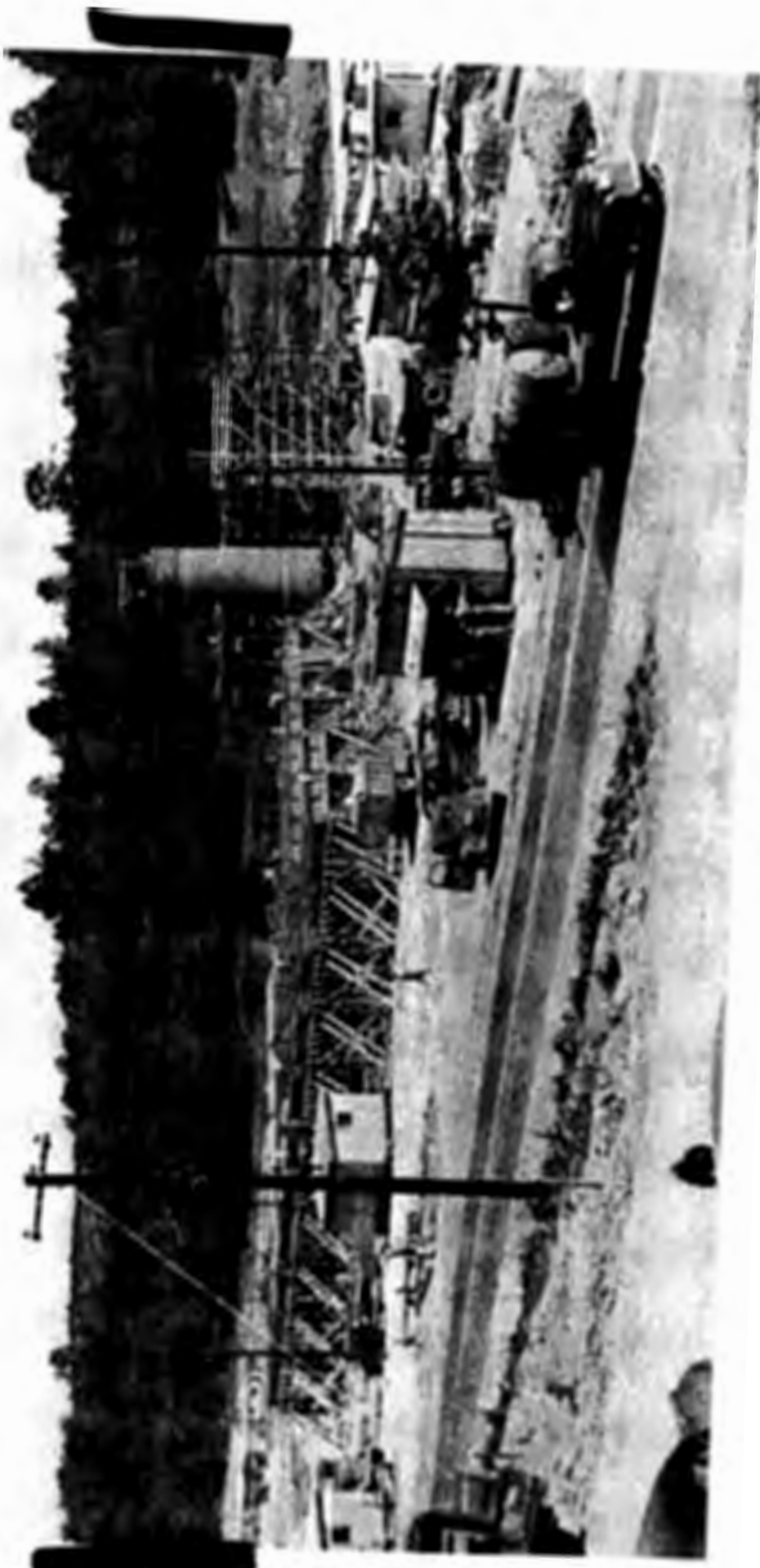

613. Development Building 9731, 22 May

1943.

Note the method used for Fern Erection shown
in the right foreground.

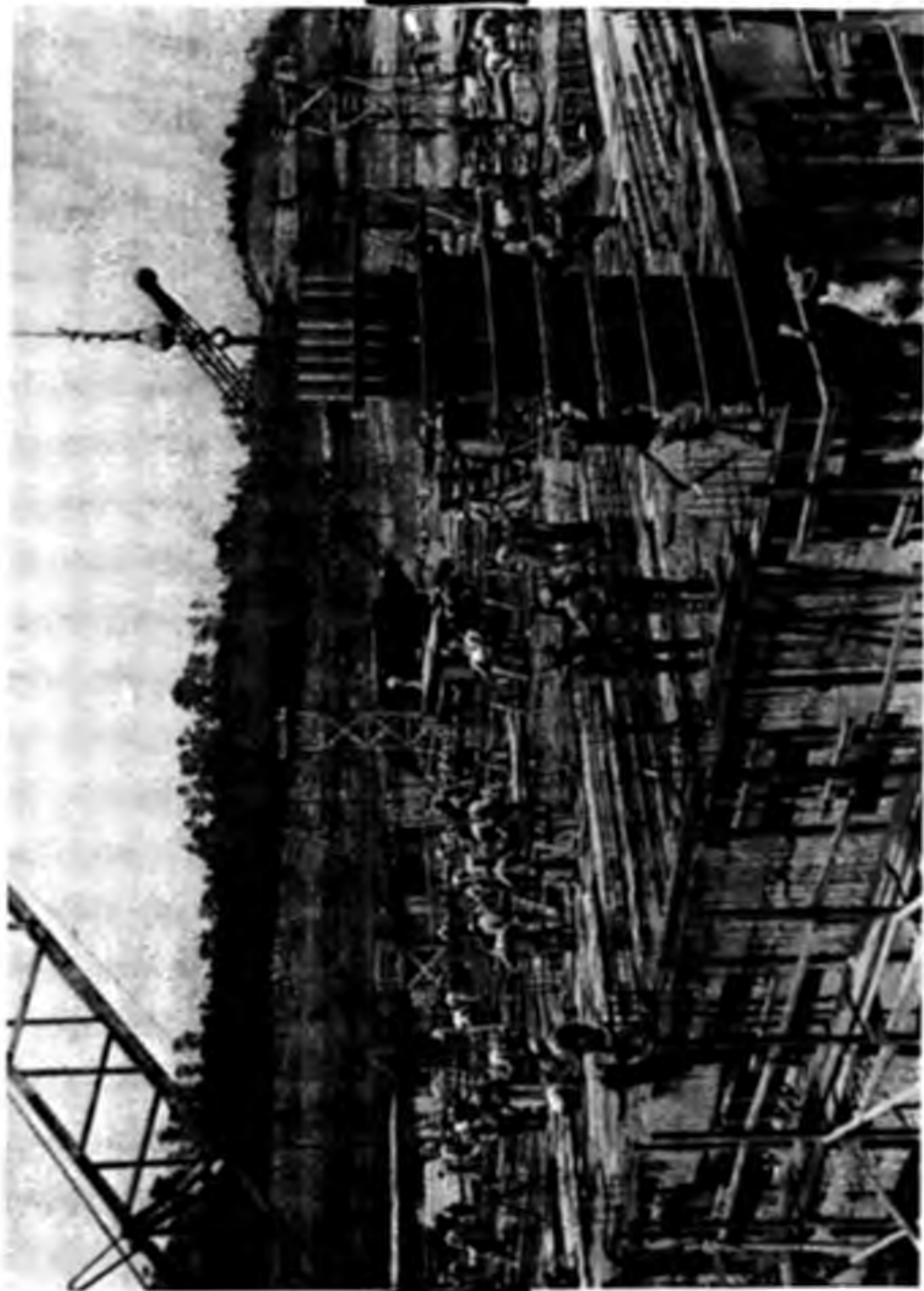

C11. Alpha Building 9201-1, 2 June 1943.

Reinforced concrete construction required huge amounts of form work.



C15. Boiler House and Beta Chemistry Building

on 8 June 1943.

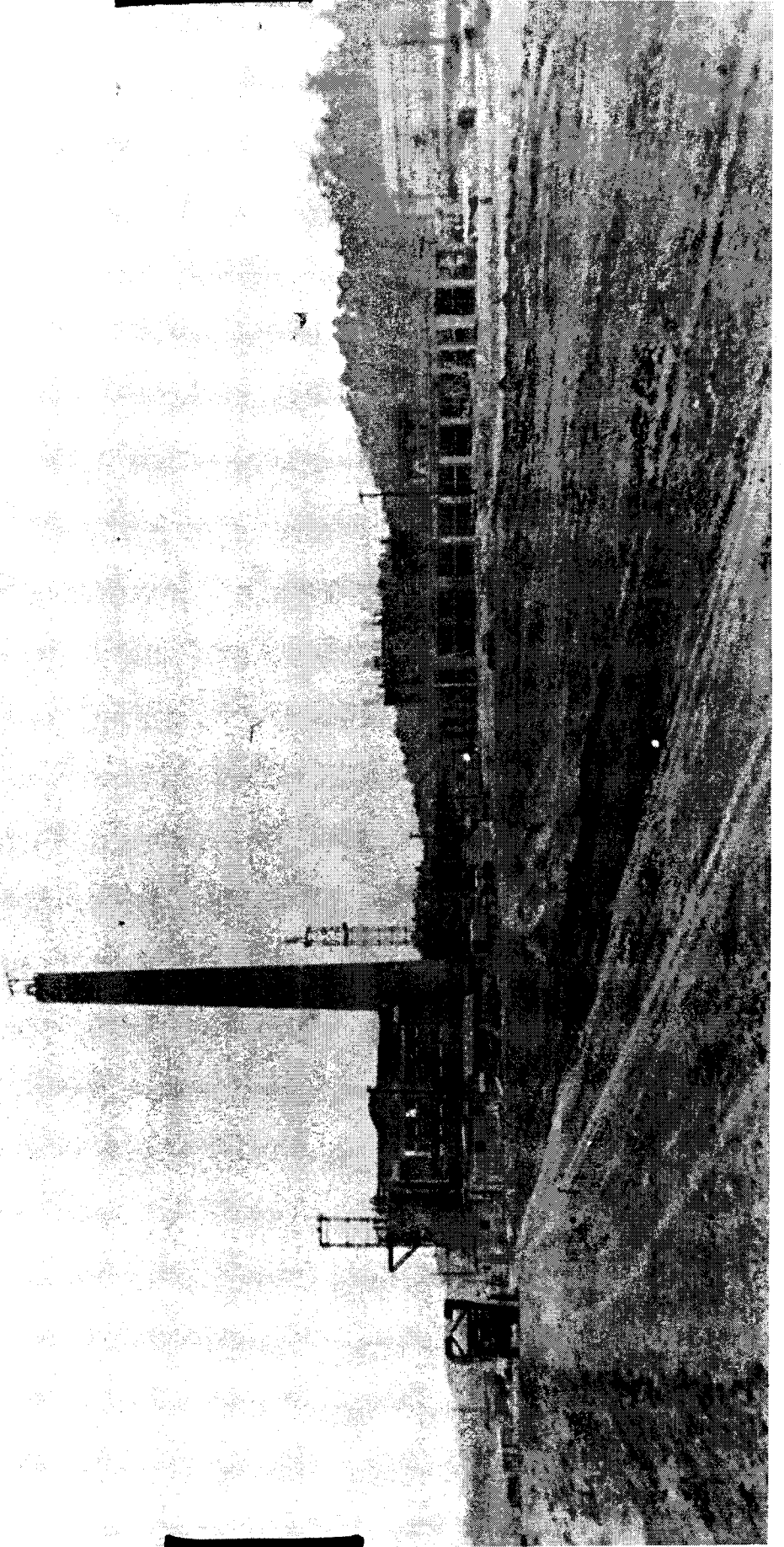

C16. Development Building 9731, 8 June 1943.

Construction of this concrete superstructure was completed in twenty-one days.

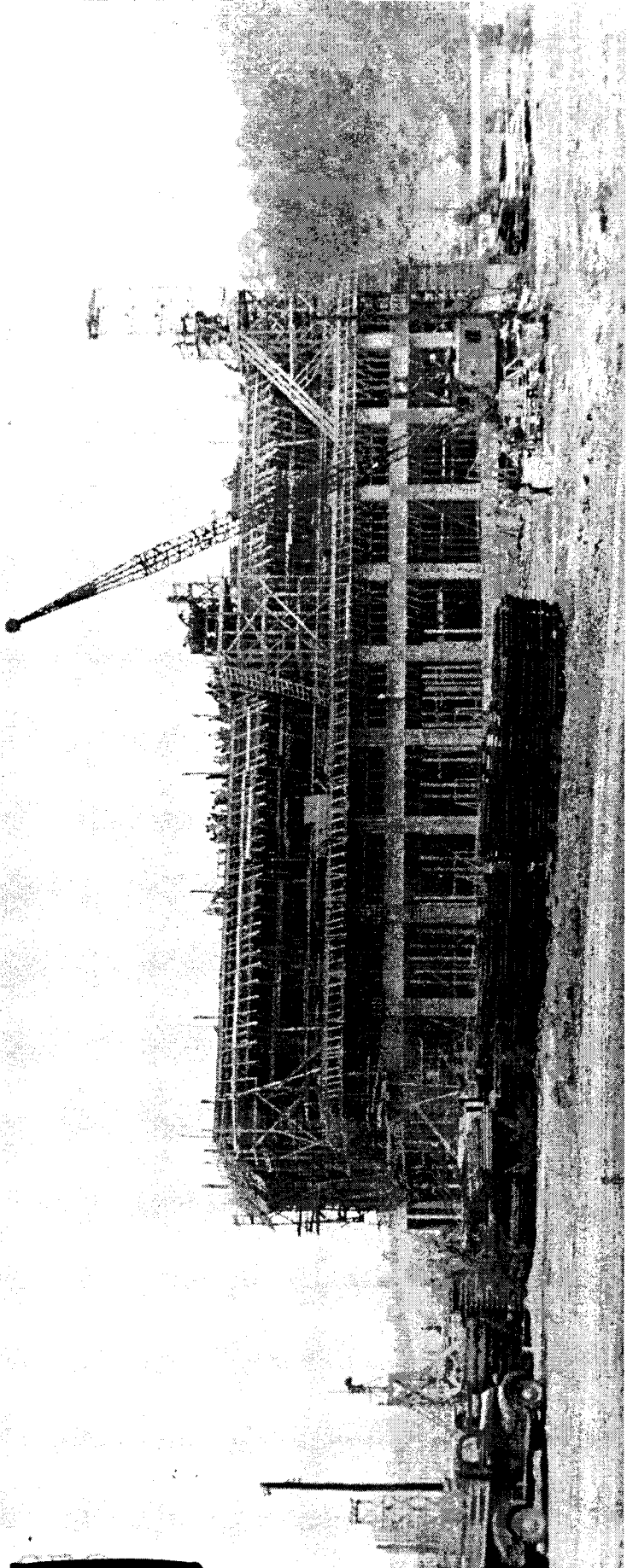

017. Experimental Racetrack (XAX)

Building No. 9731.

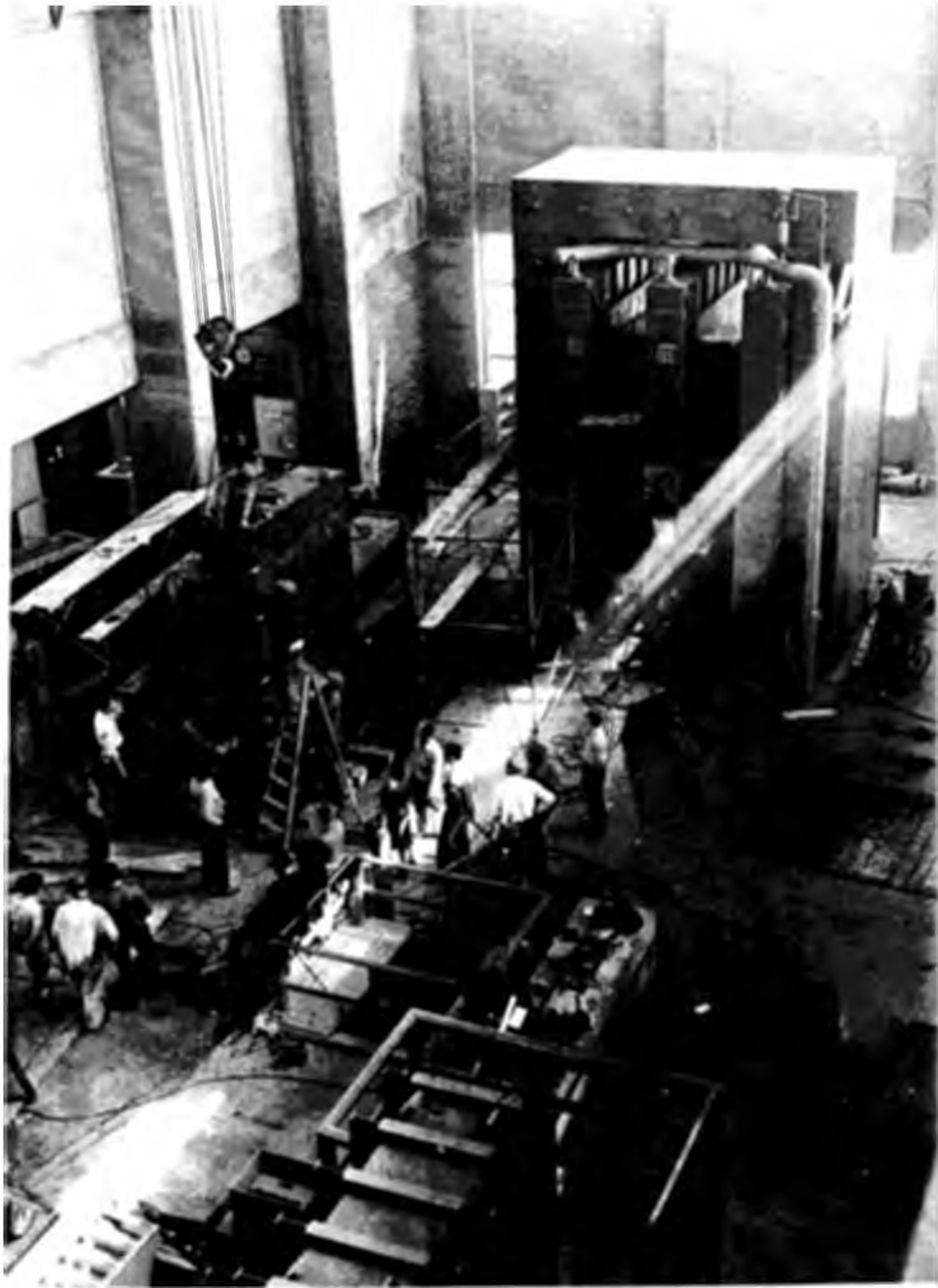

618. Alpha Chemistry Building 9202.

November 1943.

First plant operations were started here.

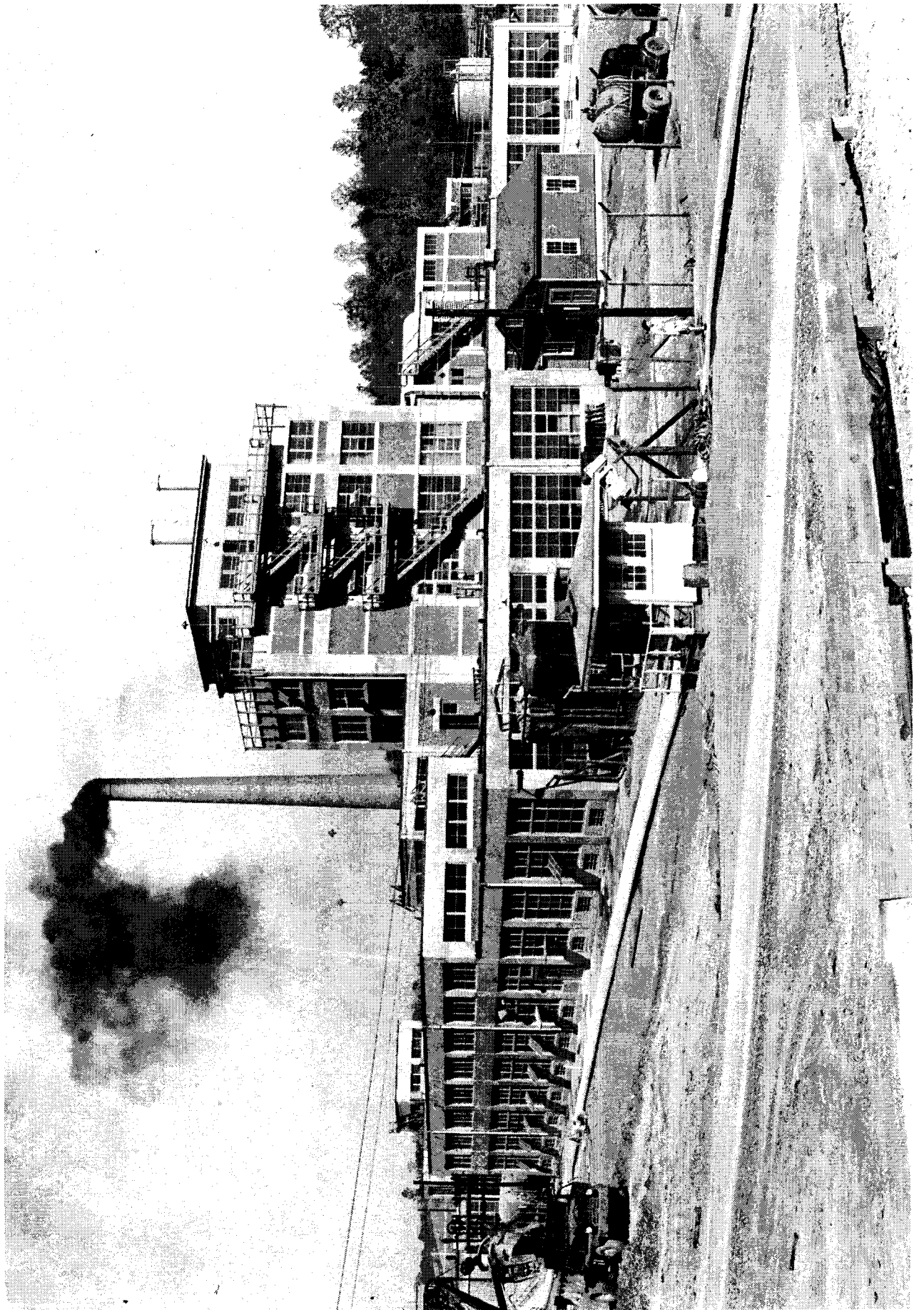

619. Y-12 Plant, December 1943.

Building 9201-1 in the center. Behind and to the right is 9201-2 and at the far right the framing for 9201-3. In the right foreground are the Cooling Towers and Pump House which were required for each process building.

On the horizon, one can see the Water Filtration Plant which served Y-12 and the Town.

[REDACTED]



C20. Completed Alpha I Racetrack

An entire installation of this type had to be
torn out and rebuilt when the first magnet failed.

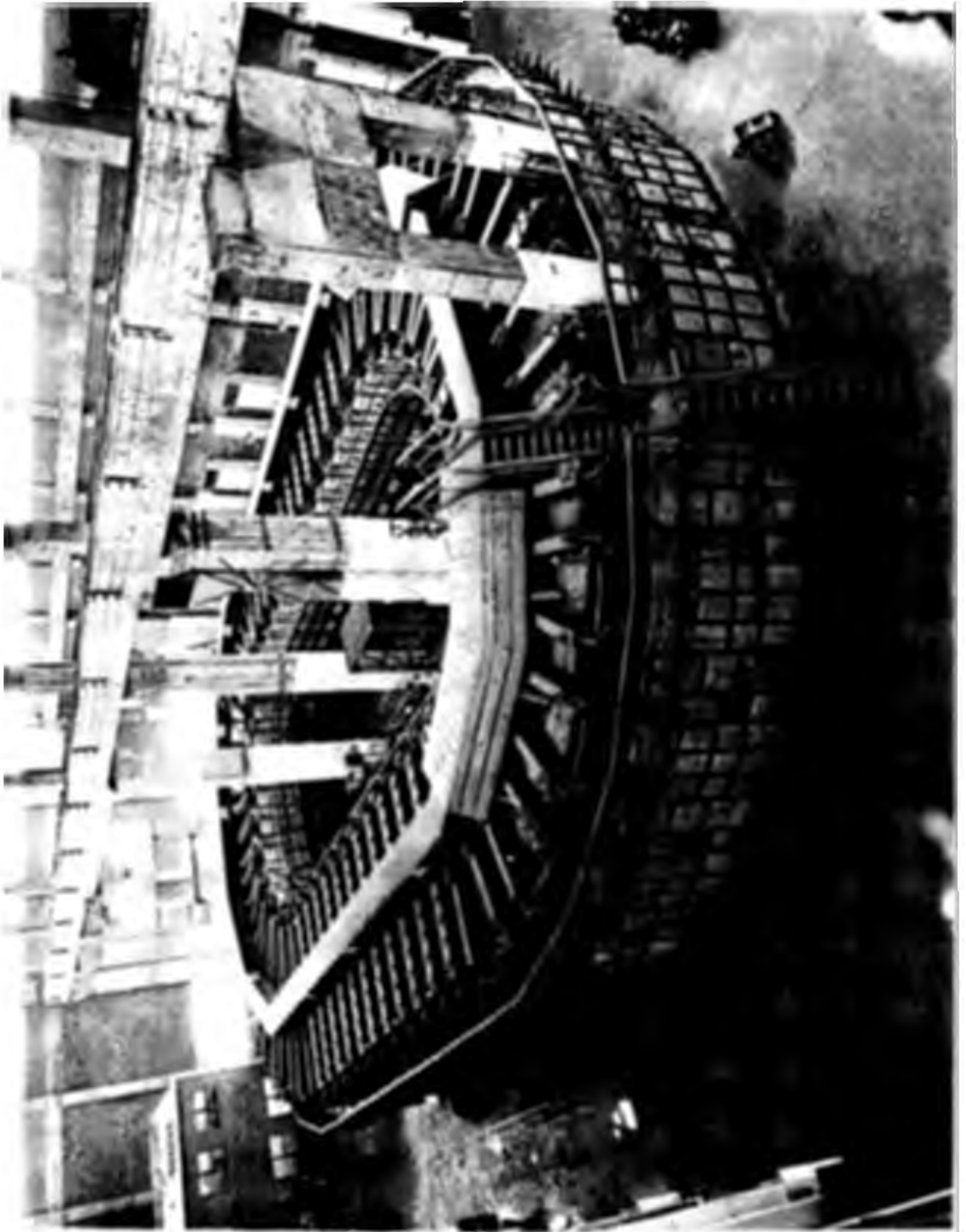

[REDACTED]

[REDACTED]

621. Y-12 Plant, March 1944.

This view looking southwest from the Water Filtration Plant shows the Alpha I buildings to the left, Beta Building Y204-1 in the right center and the start of Y-12 Extension to the fore right.

1



1

C22. Construction of Beta Chemistry Building

9206, May 1944.

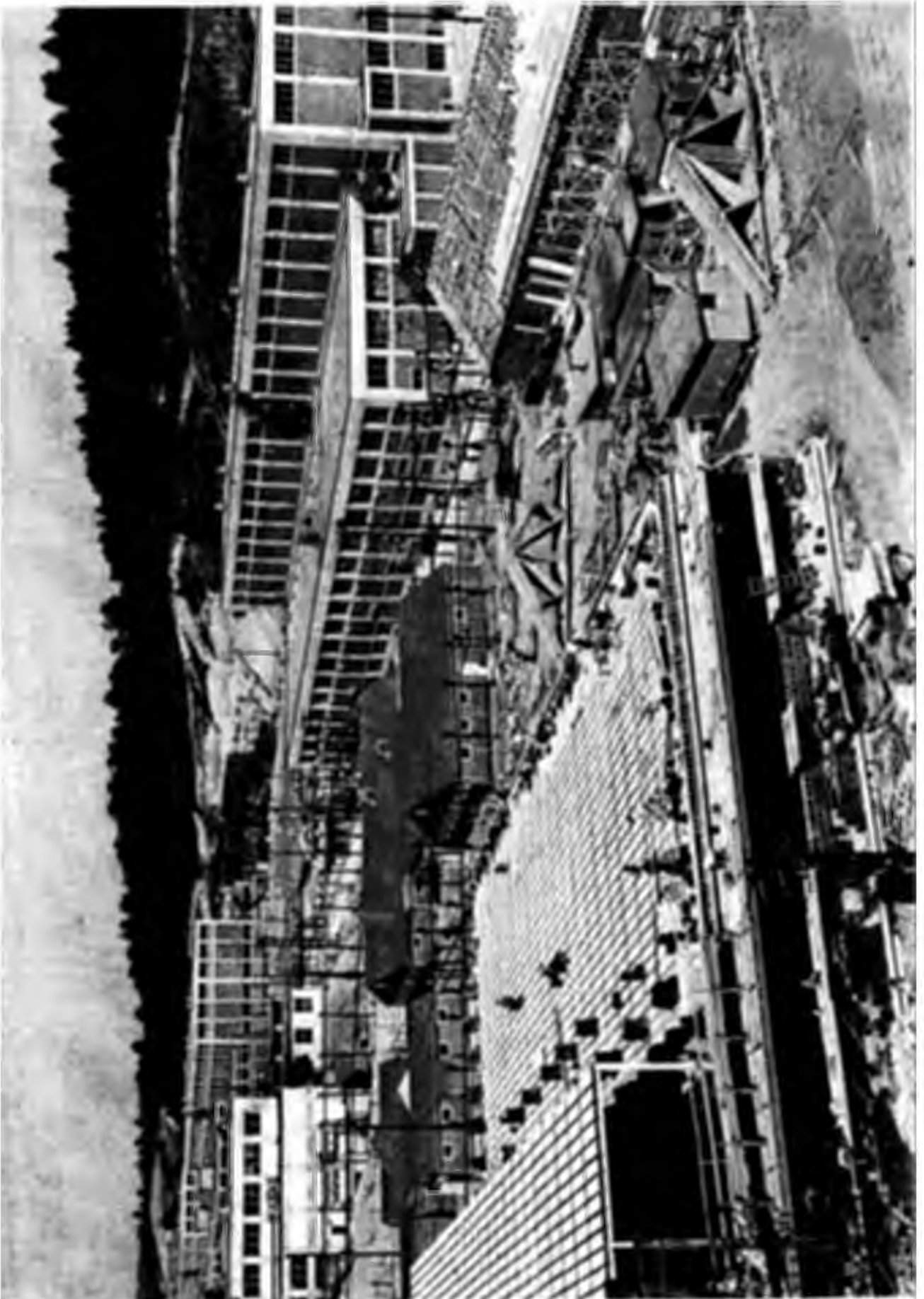

C23. Alpha II Process Building 9201-4

under construction, January 1964.

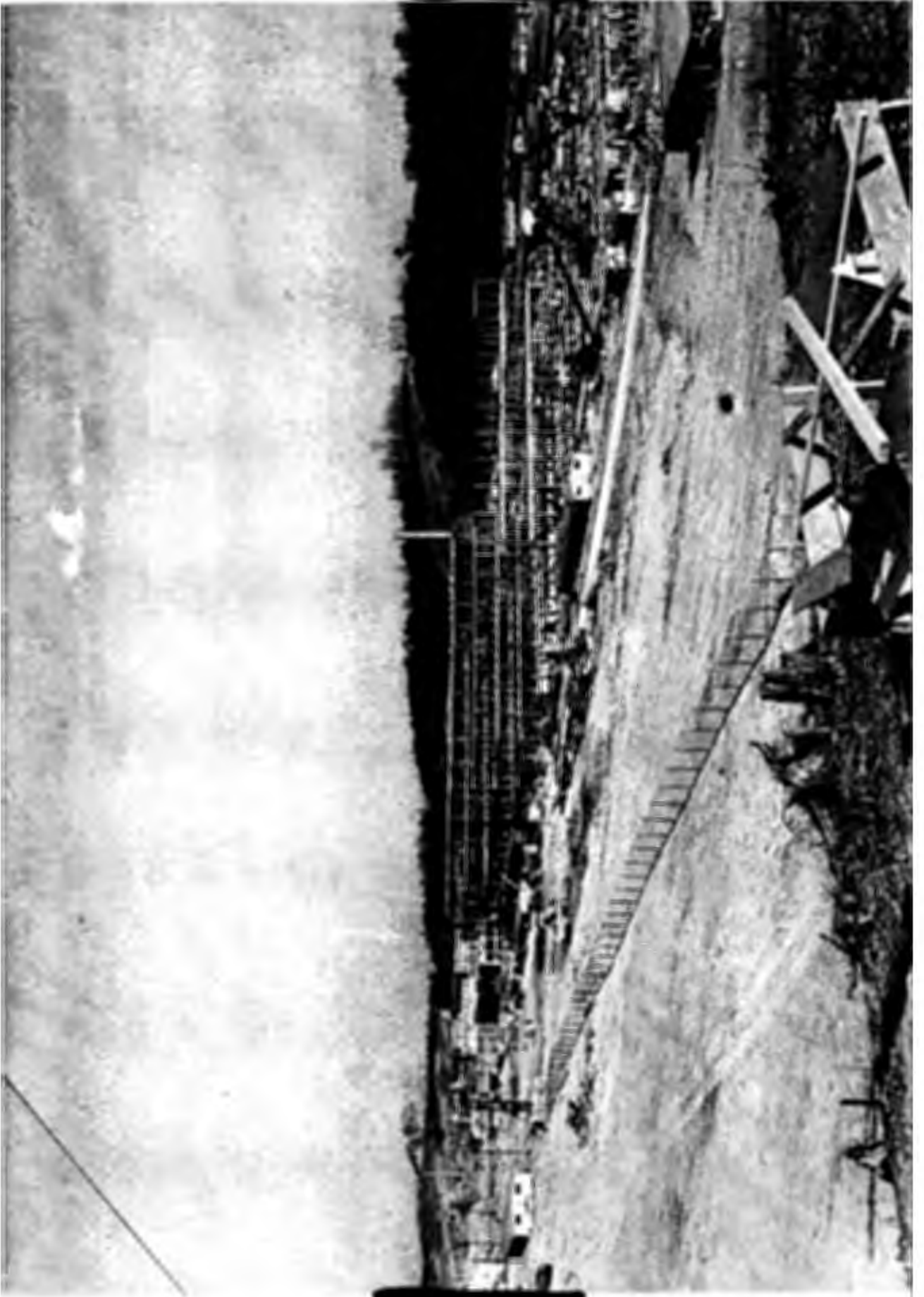

021. Pump House and Cooling Tower

21 February 1944.

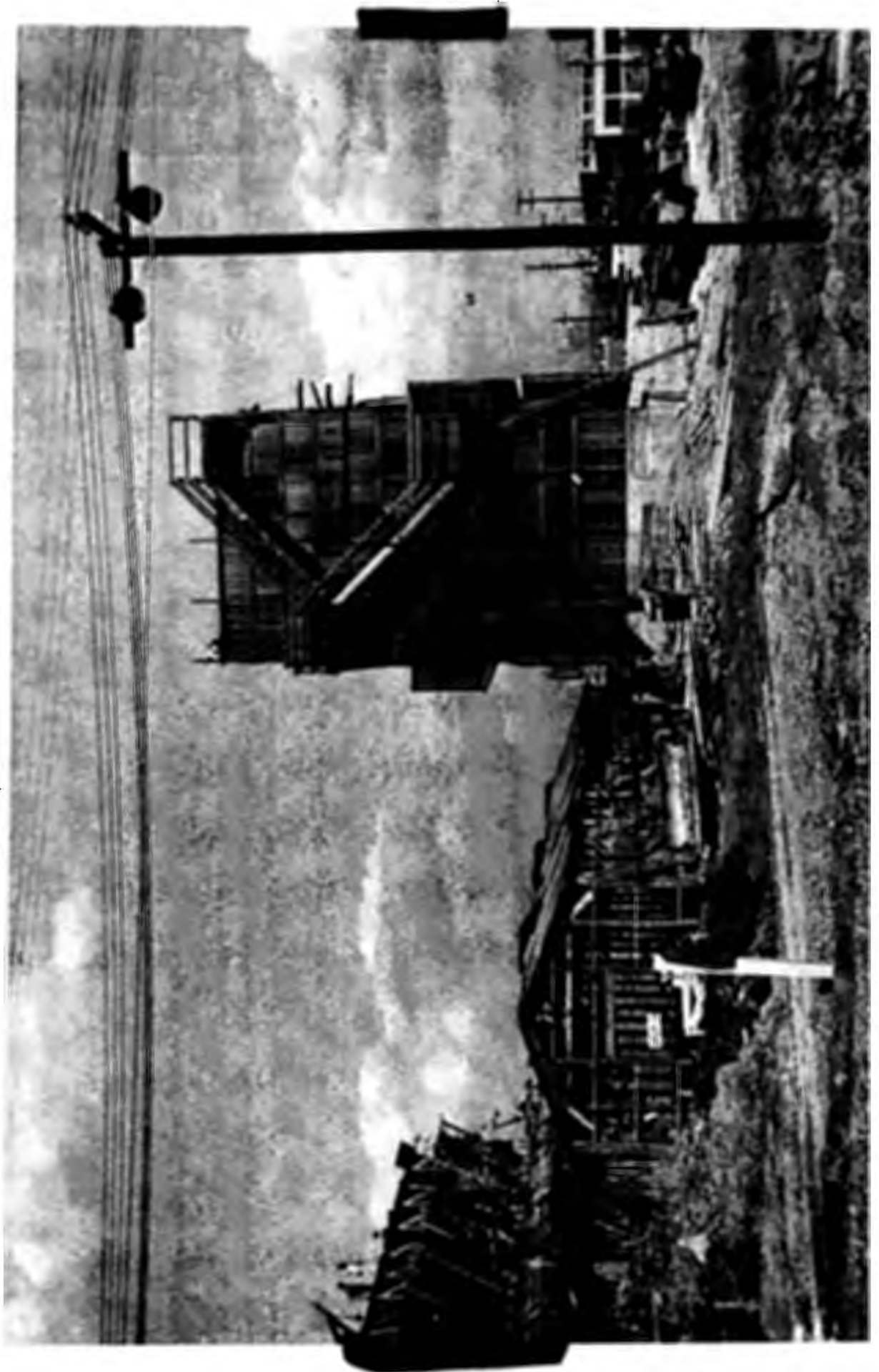

025. The Second Boiler House 9401-2 under
construction 24 February 1944.

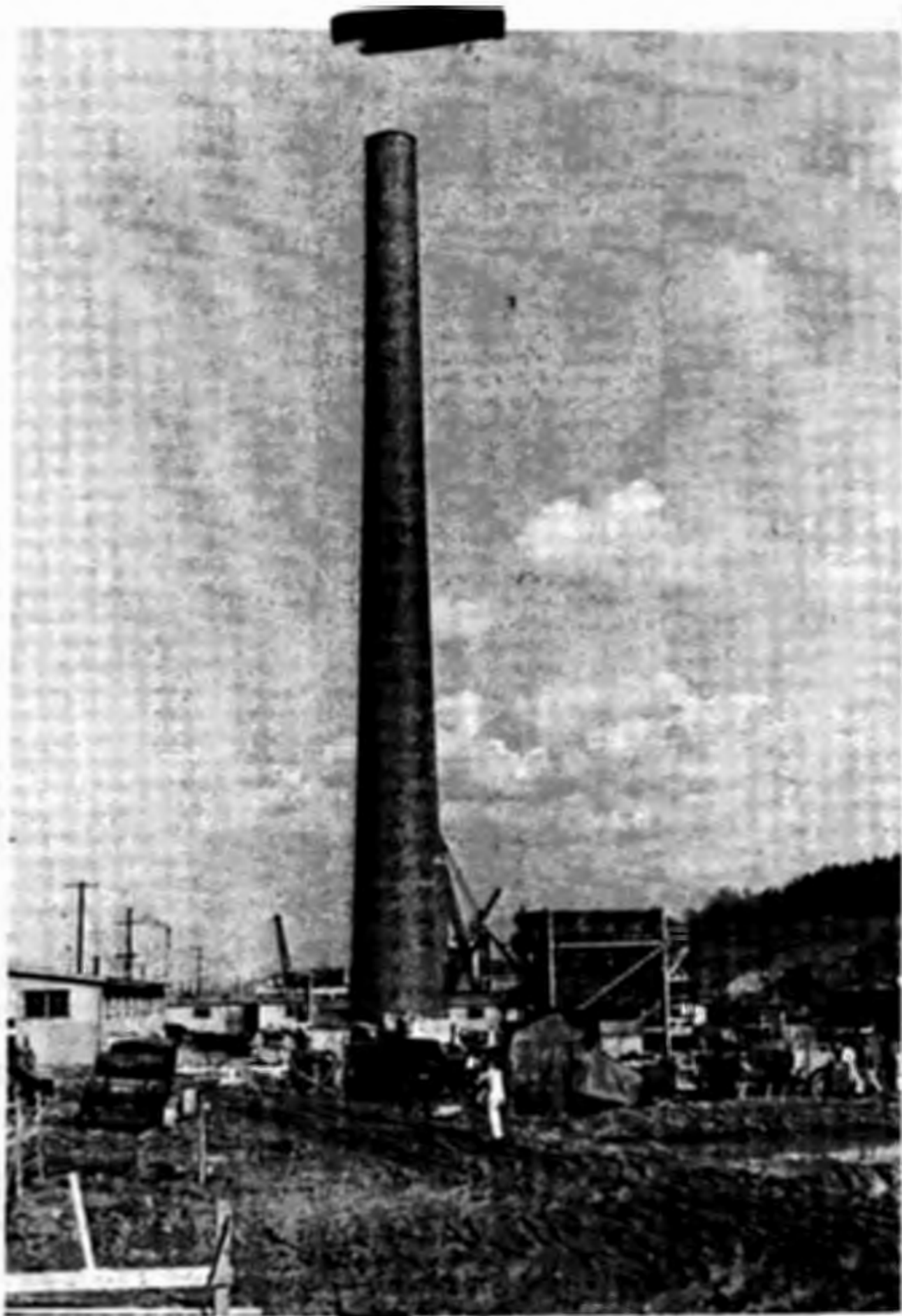

026. Alpha II Process Building 9201-4

24 February 1944.

Note the comparative simplicity of steel erection as against the forming for the earlier reinforced concrete buildings.

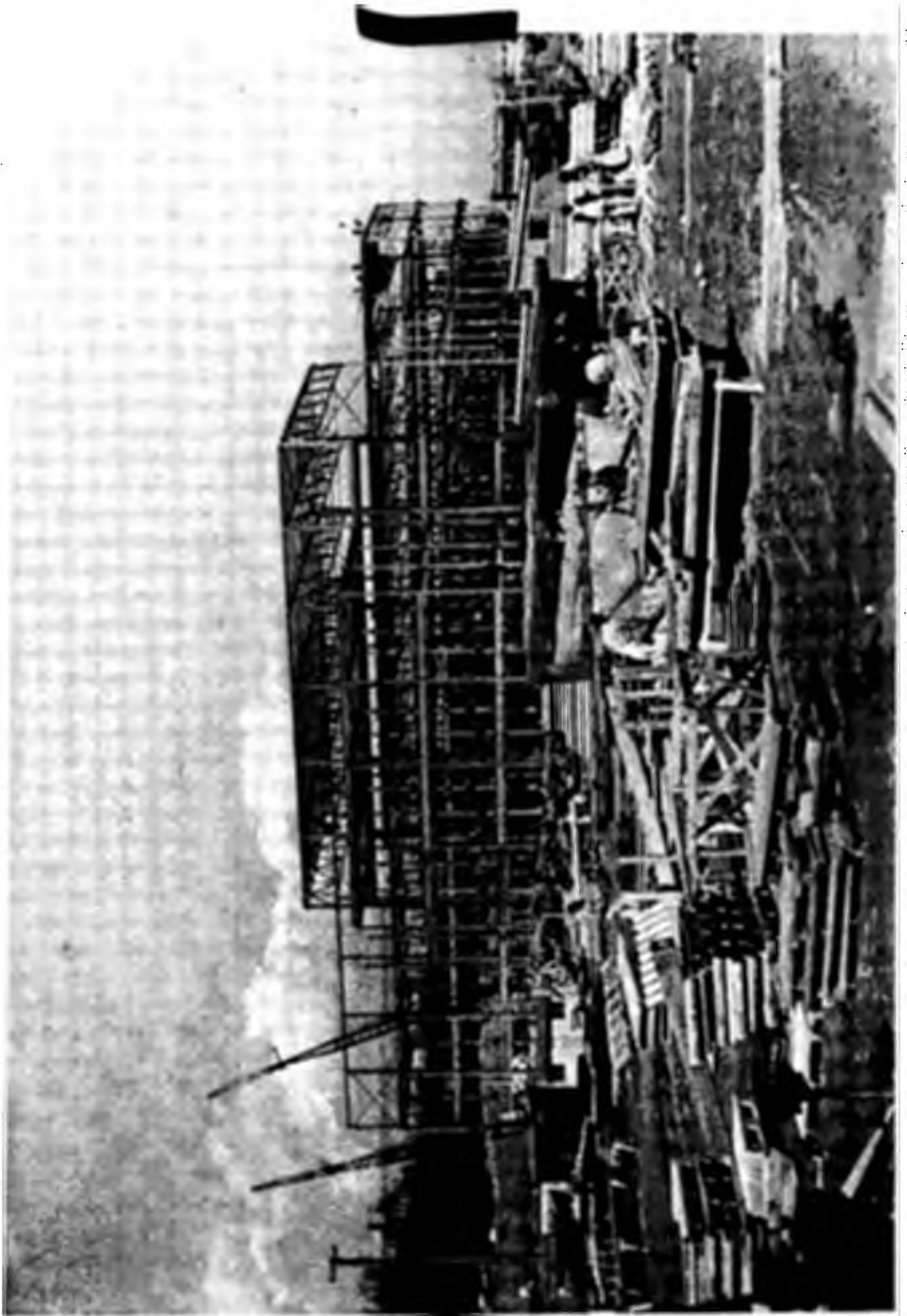

027. Beta Process Building 9204-2

24 February 1944.

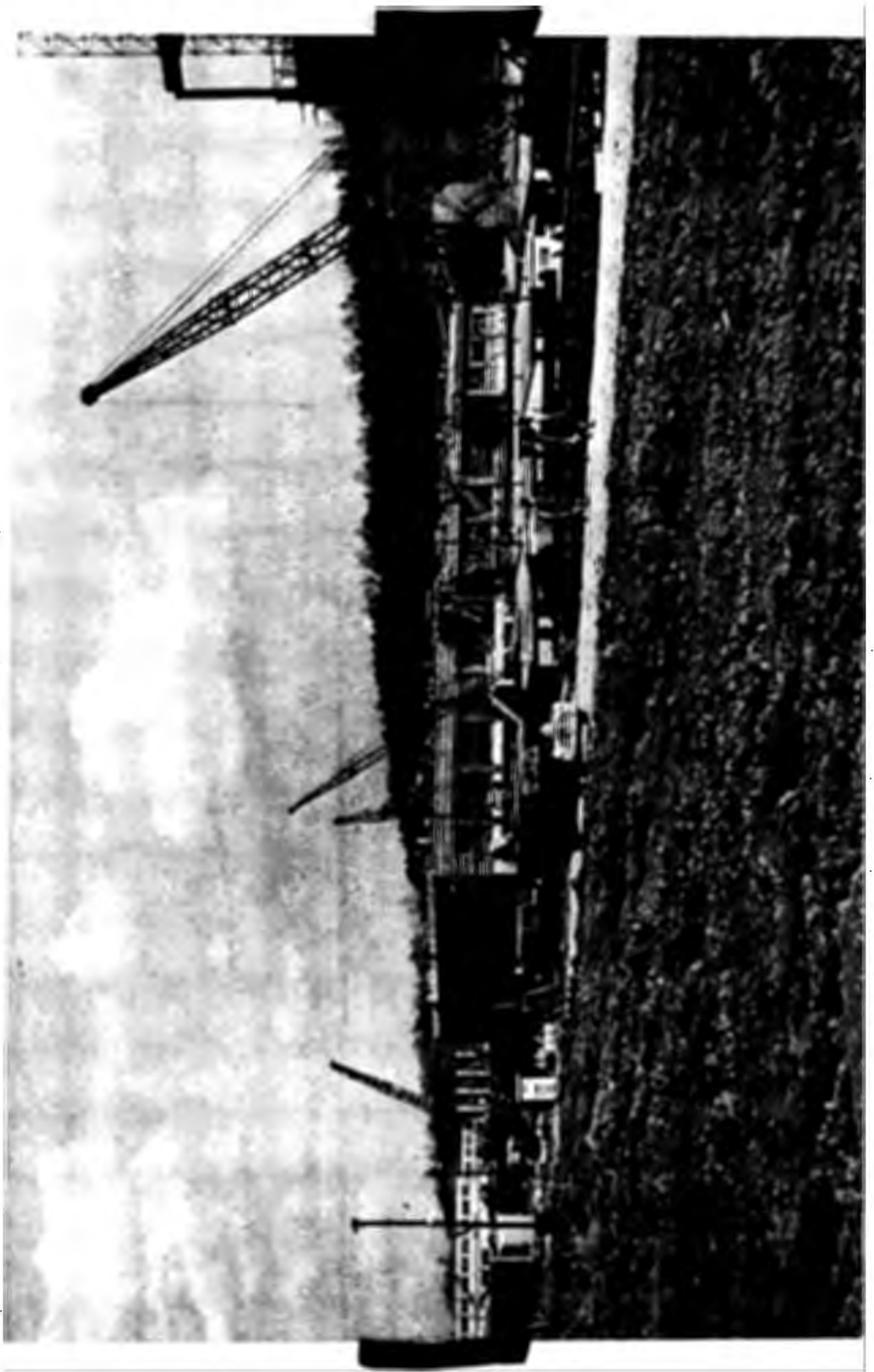

C28. Y-12 Plant, March 1944.

The parking lot in the foreground became
the site for the 9207 group of Chemistry
Buildings.

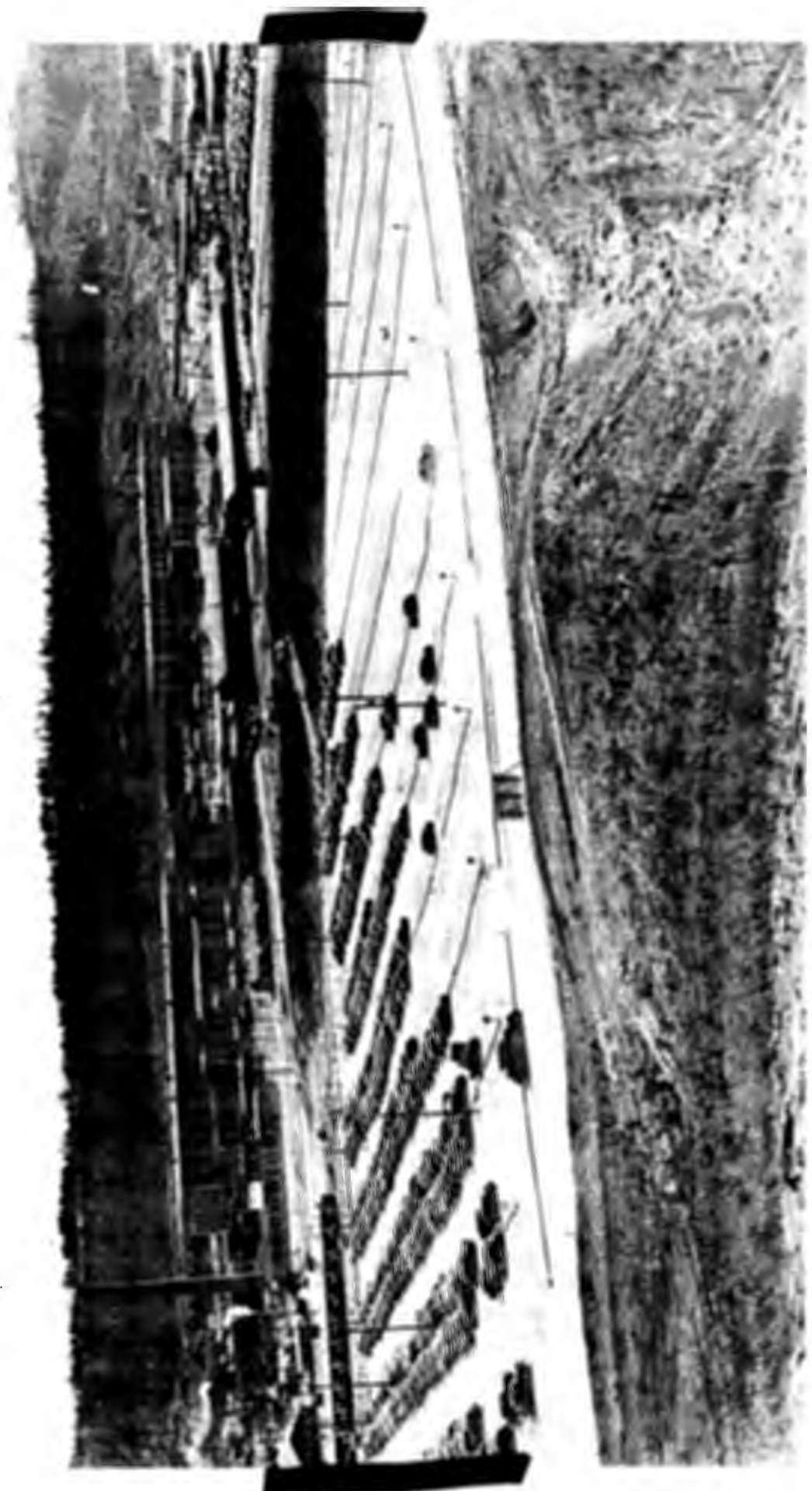

629. Y-12 Extension, March 1944.

Framing well along on Alpha Building 9201-4.
Foundation started for 9201-5.

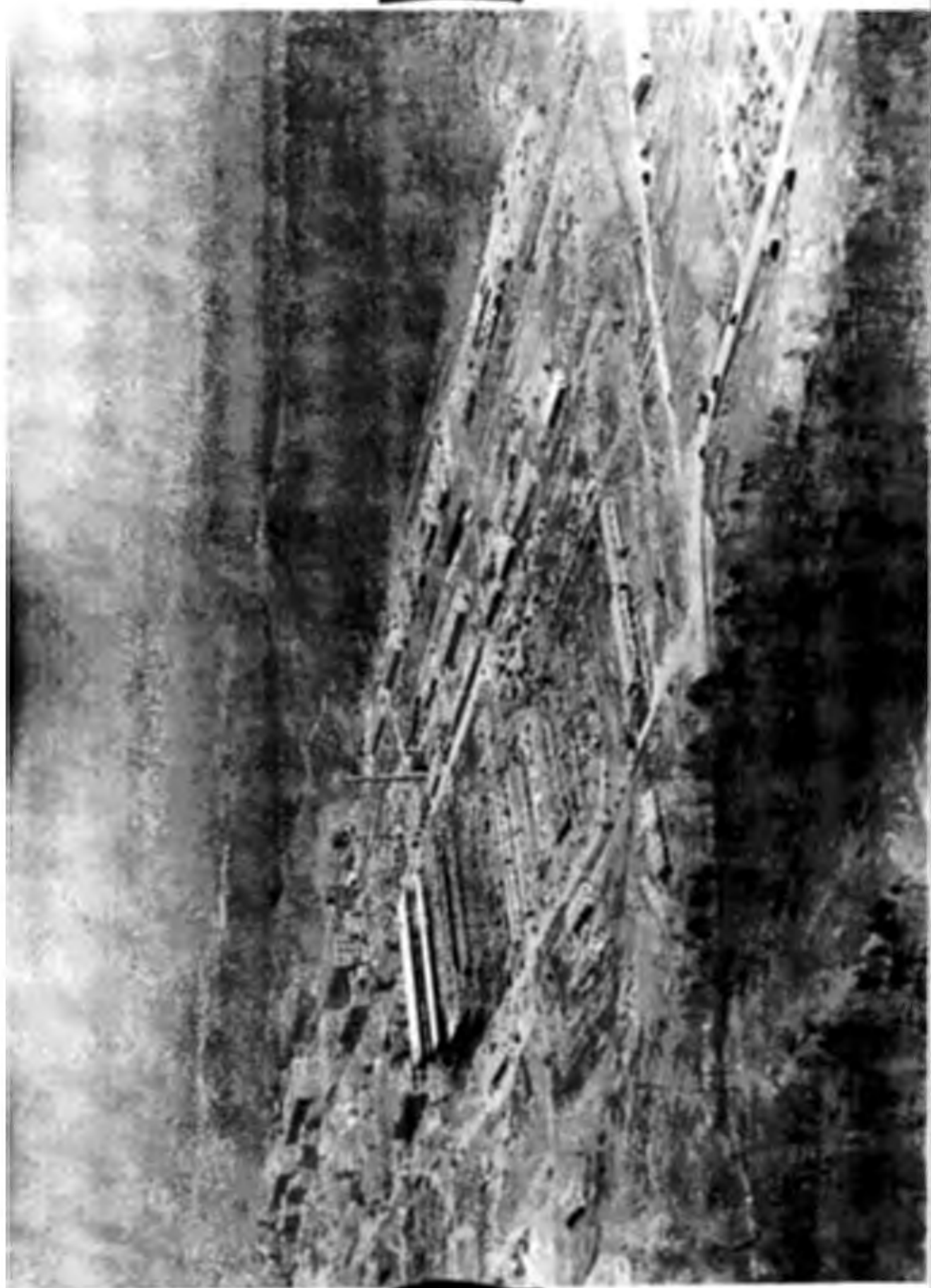

C50. Beta Process Building 9201-2

March 1944.

Note that this second Beta Building retained
the reinforced concrete framing design.

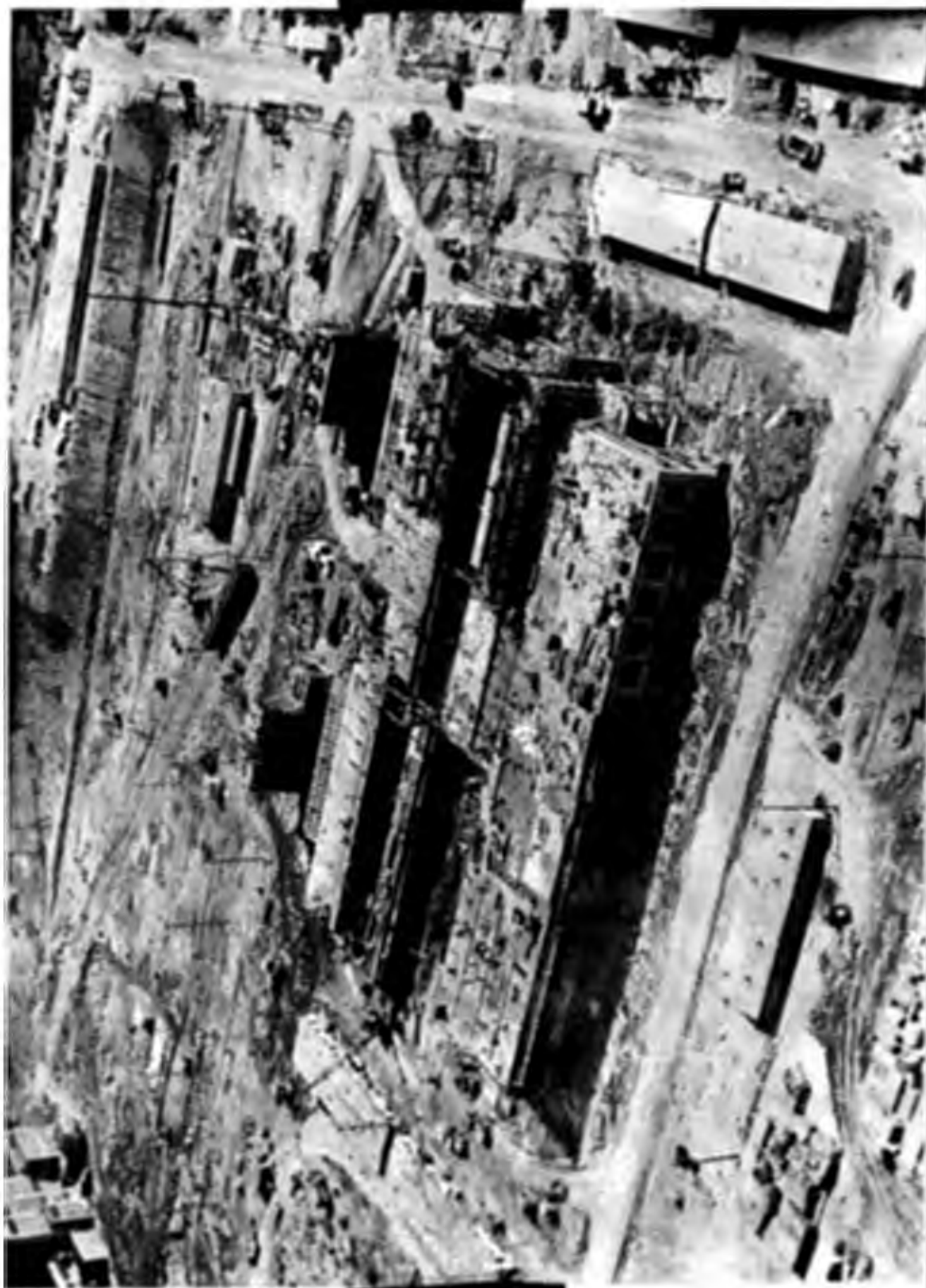

C51. Alpha II Process Building 9201-4

March 1944.

This building is being roofed over ready for equipment installation. Each high bay houses one racetrack.

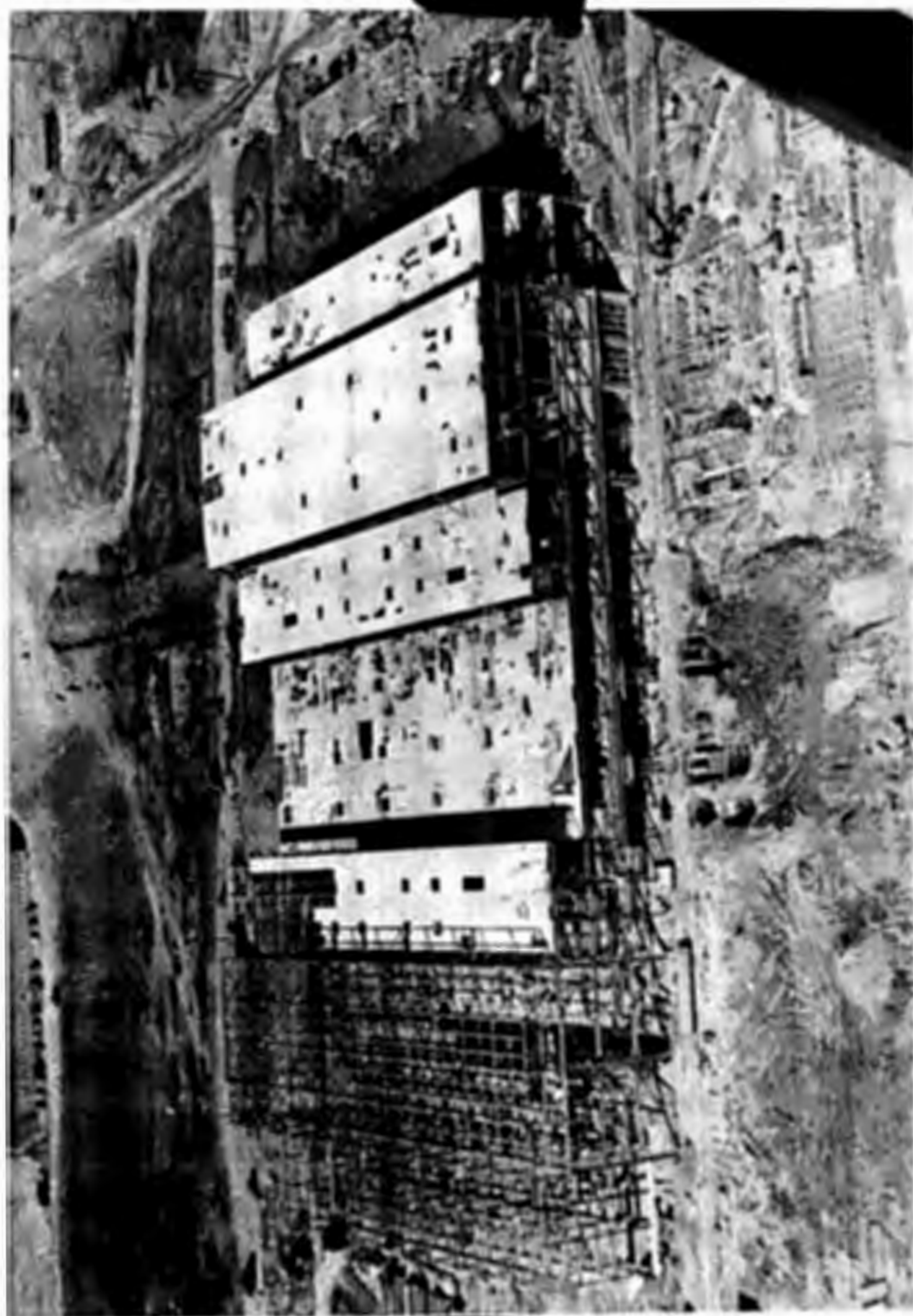

032. Alpha II Racetrack Installed.

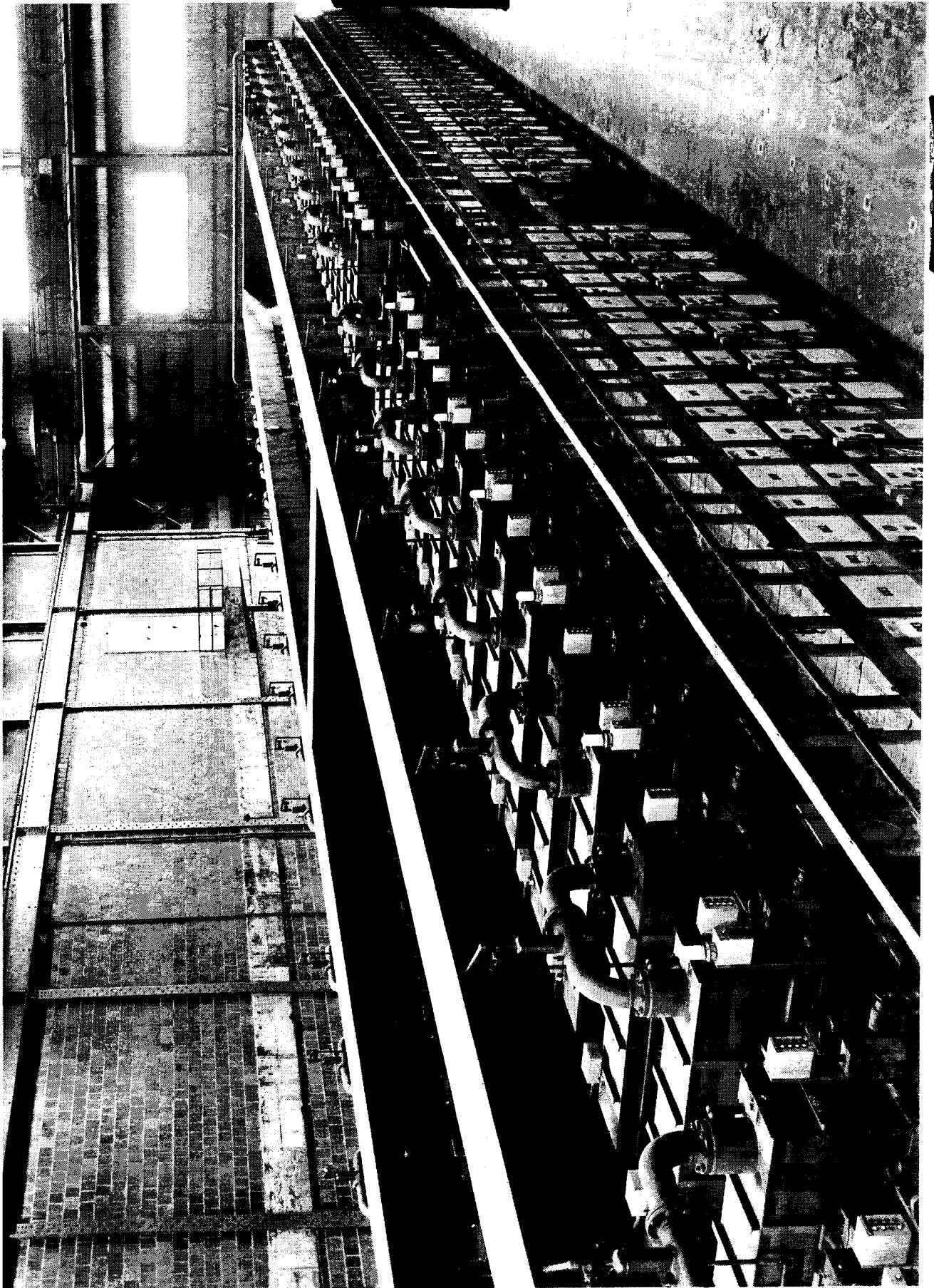

C53. Panoramic View of the Y-12 Plant

March 1944.

The mass of poles in the foreground is one of the two substations delivering TVA Power to the Plant.





C34. Beta Process Building 9204-2, ready for
equipment installation 19 April 1944.



035. Aerial View of Midway Storage Area.

22 May 1944.

Secret equipment for Y-12 Plant was stored here until time for installation. In the background lies the Town of Oak Ridge.



C36. Aerial View of Y-12 Extension, June 1944,

Looking Southeast.



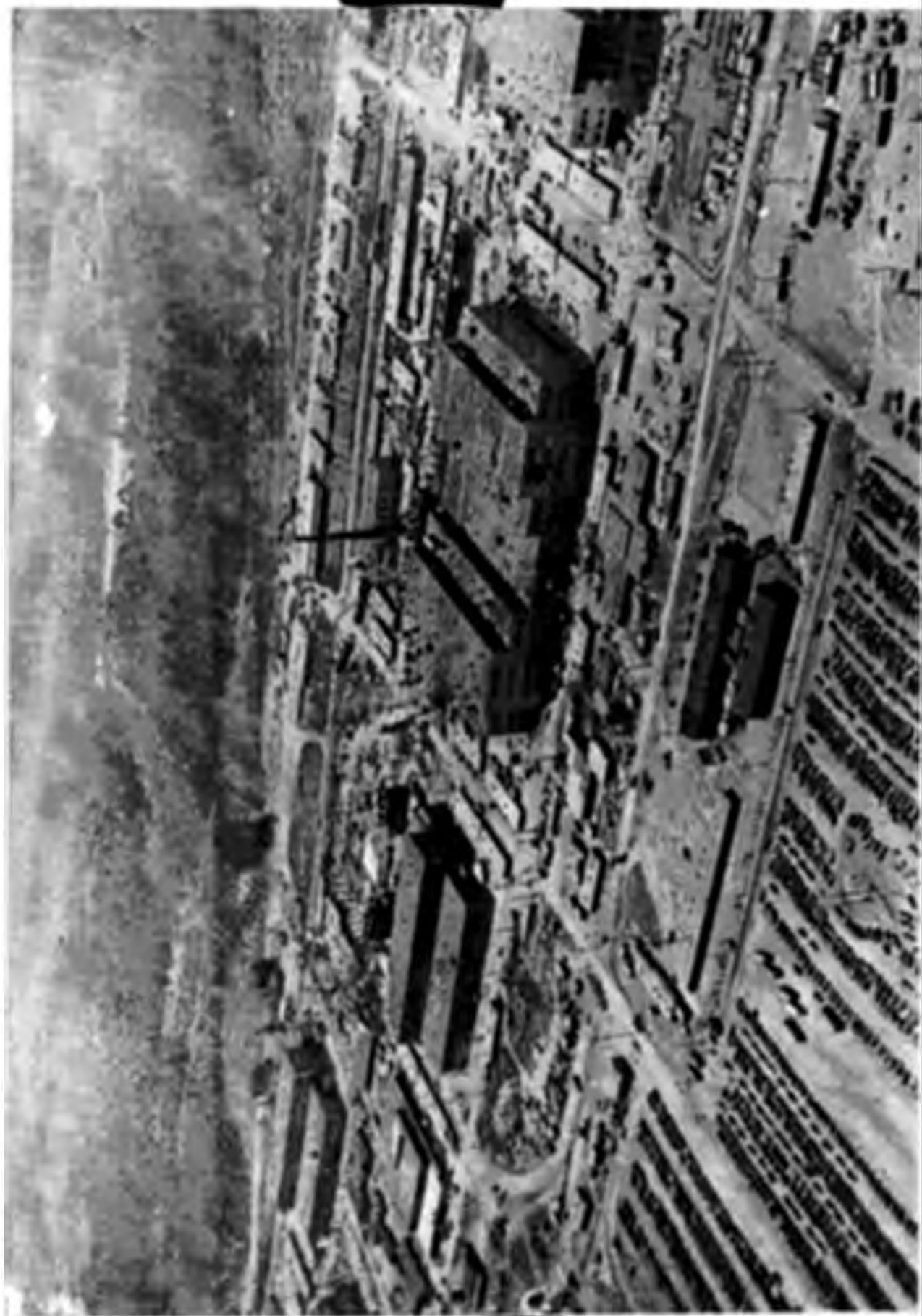

637. Aerial View of Y-12 Extension, June 1944.

Looking West.

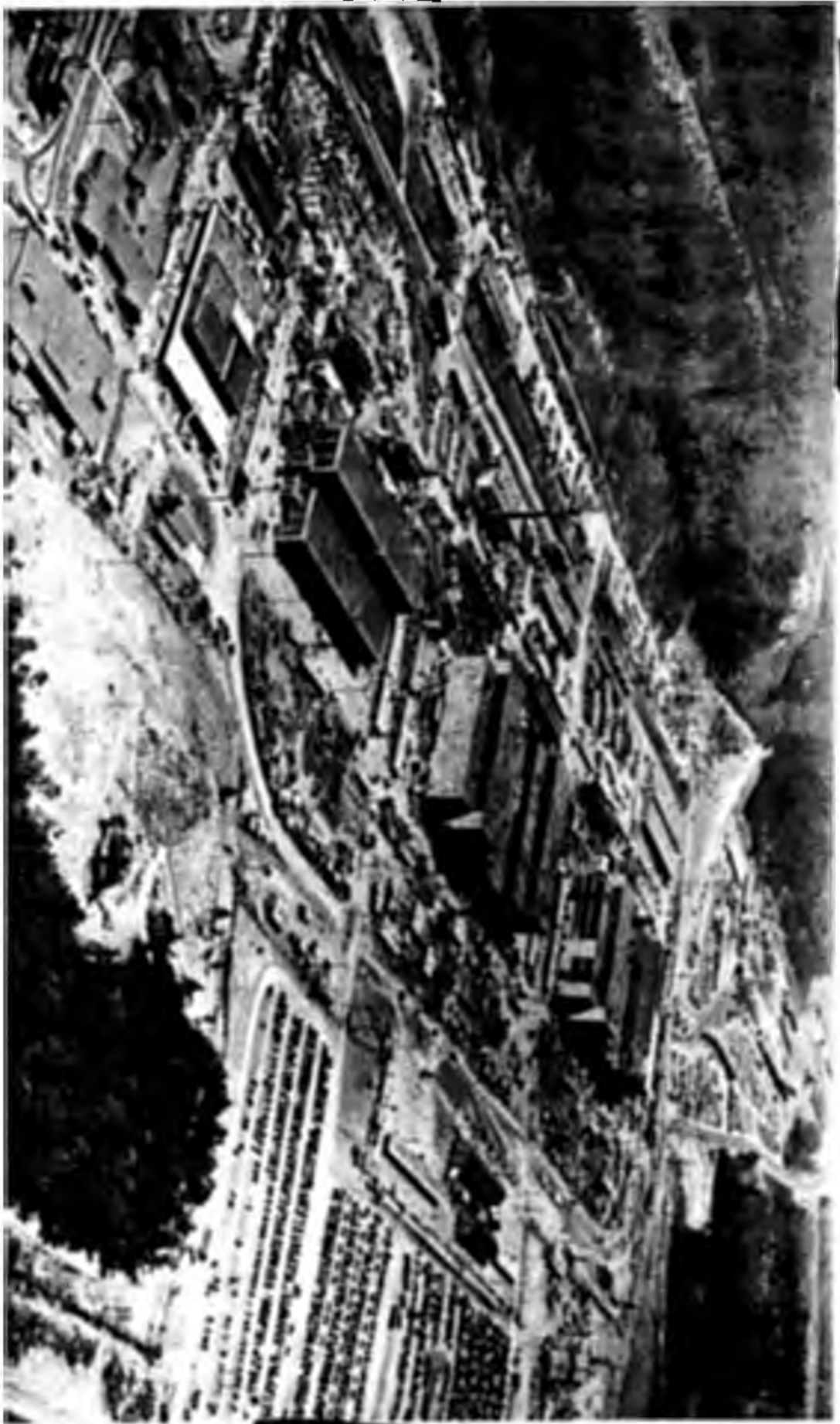

C38. Alpha II Drydocks

This equipment is used to test the cleaned and rebuilt units before returning to the race-tracks for another separation run.

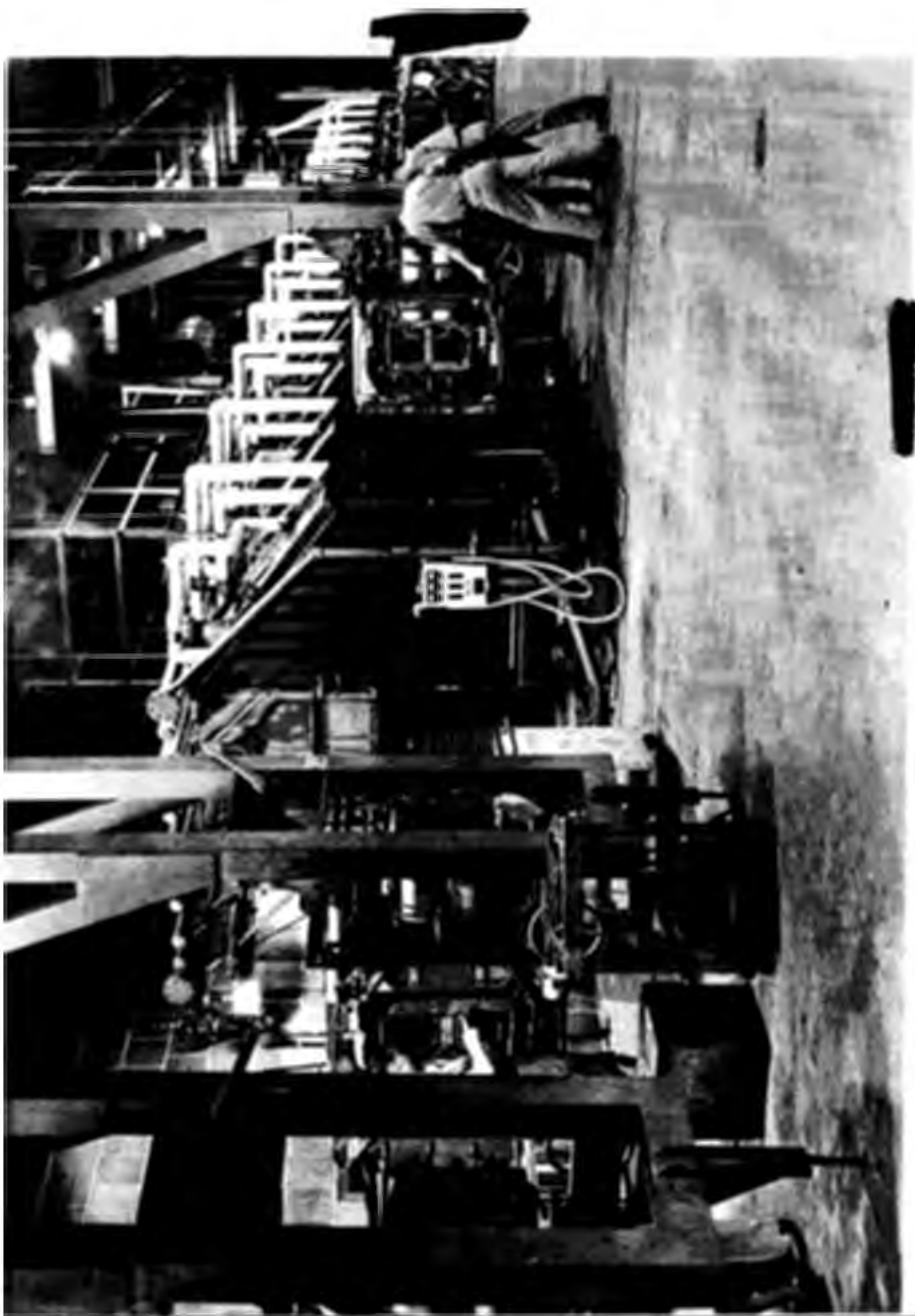

679. Y-12 Plant, September 1944.

View looking Northeast with Extension
Area to the left.



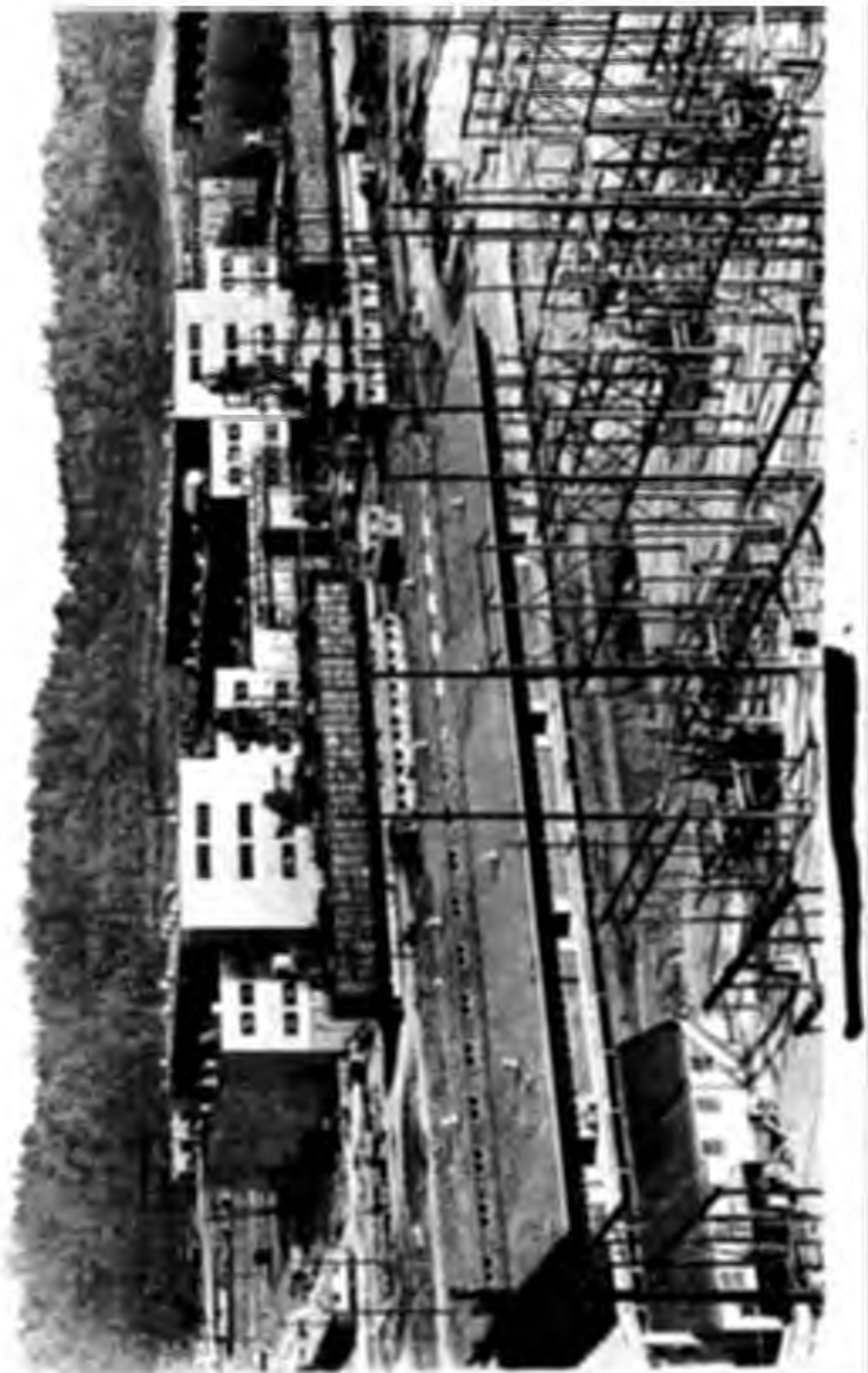

ChO. Beta Process Building 9204-3

September 19th.

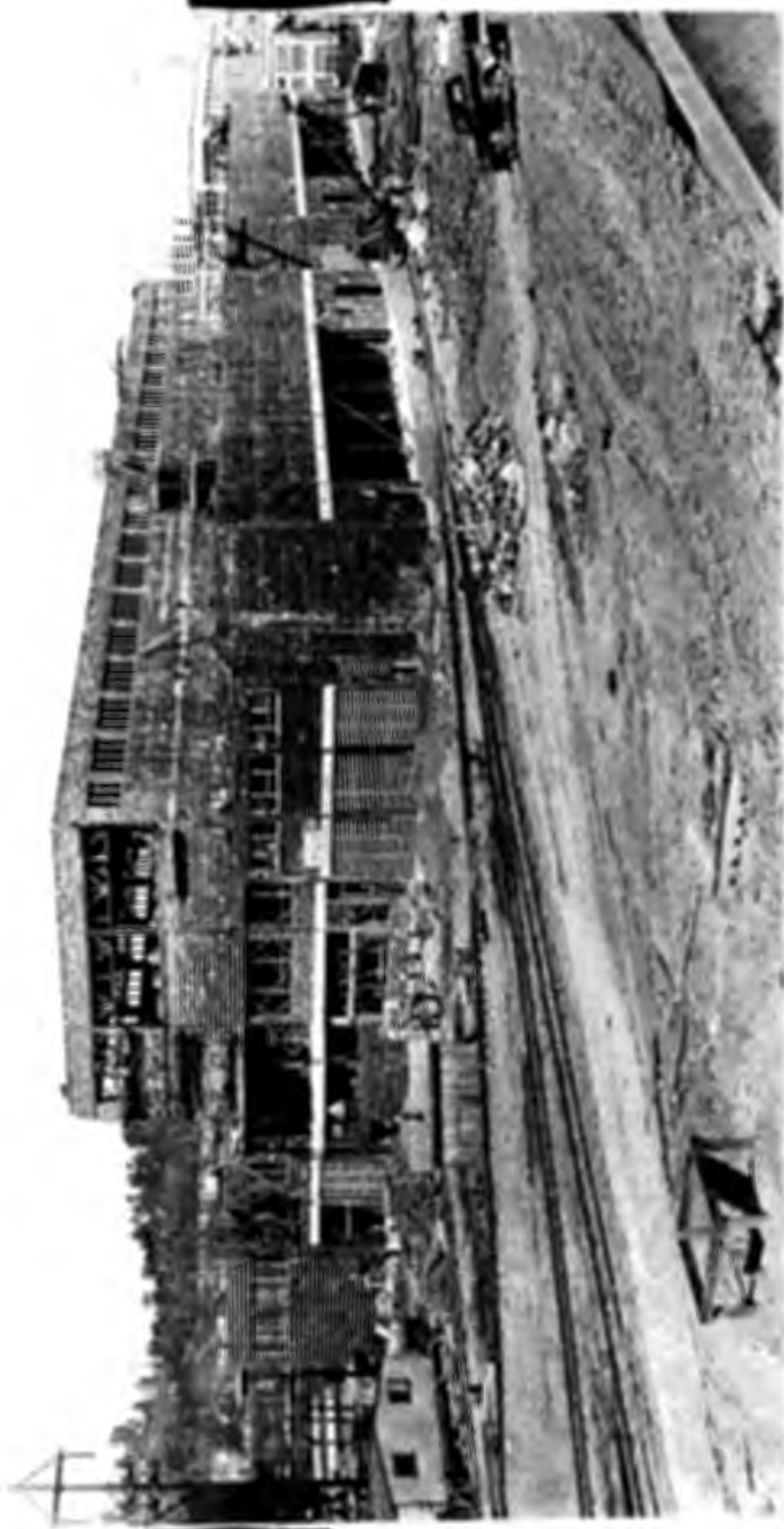

22 ?

Cl. Typical Beta Racetrack Installation.

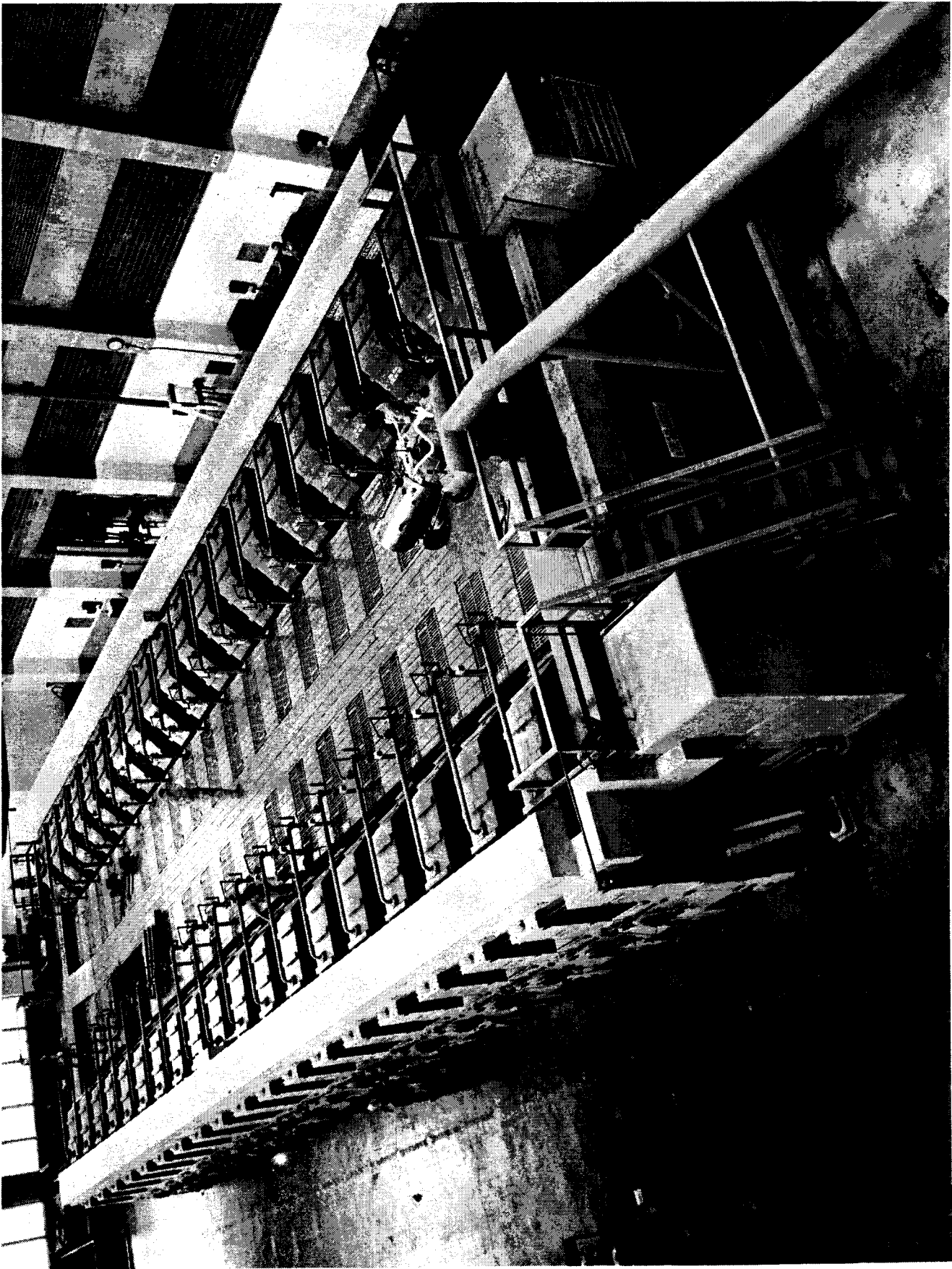

042. Alpha Chemistry Building 9202

September 1944.

This photograph shows construction of the extension to the original building required by expanded process facilities.

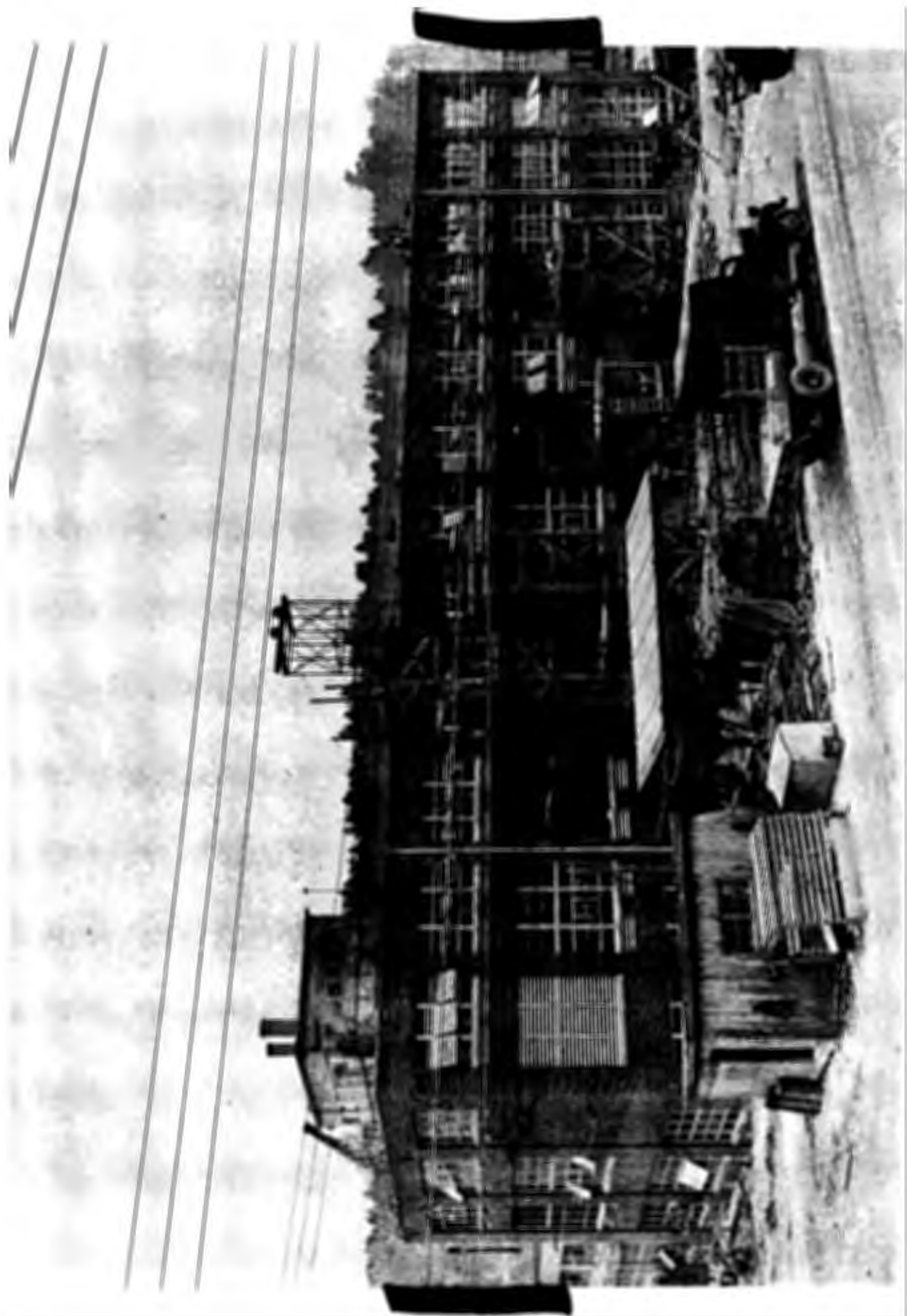

613. Construction of Extension to Boiler

House 9601-1, September 1944.

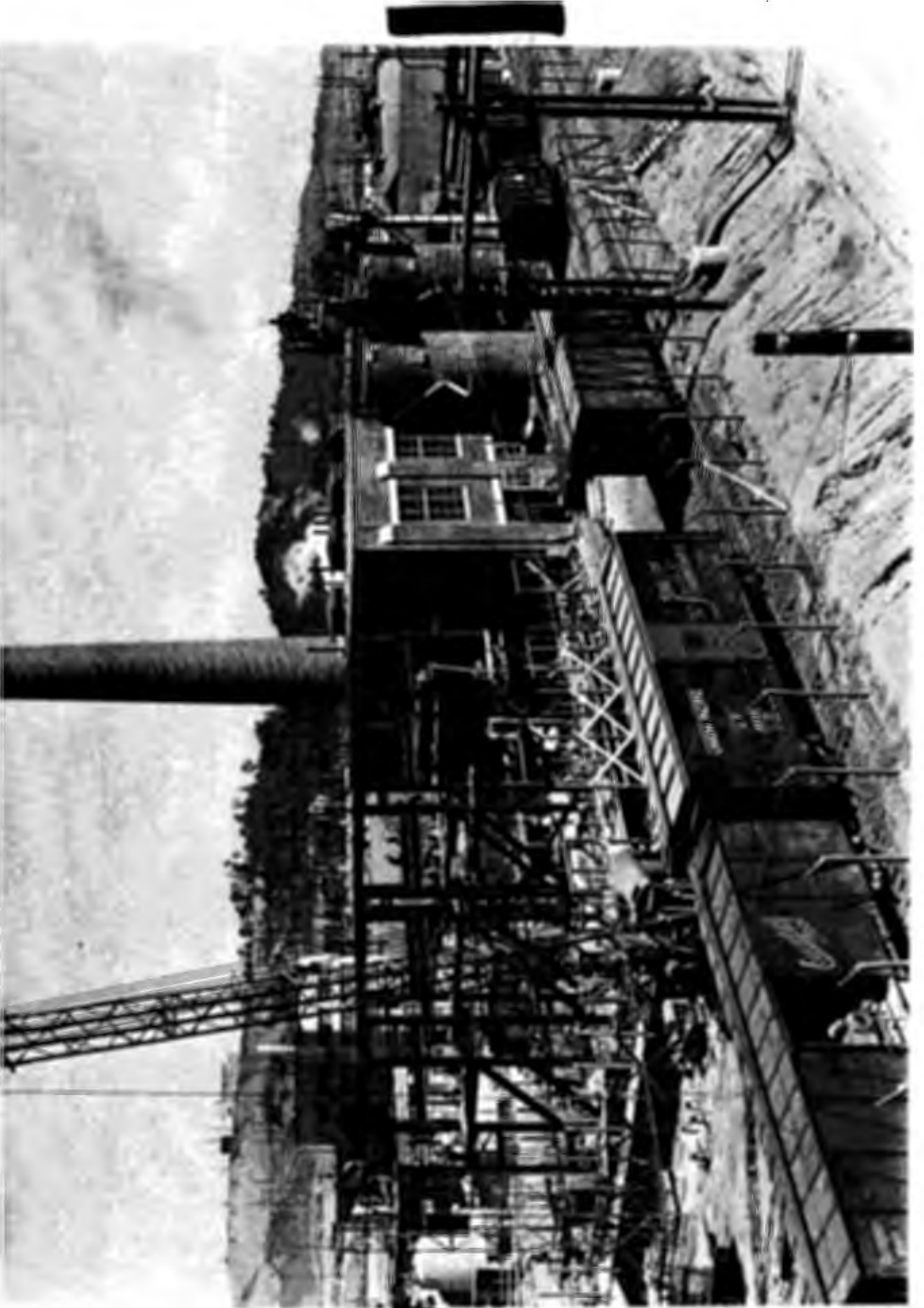

Ch. Construction of 3207 Group of Alpha
Chemistry Buildings, September 1944.

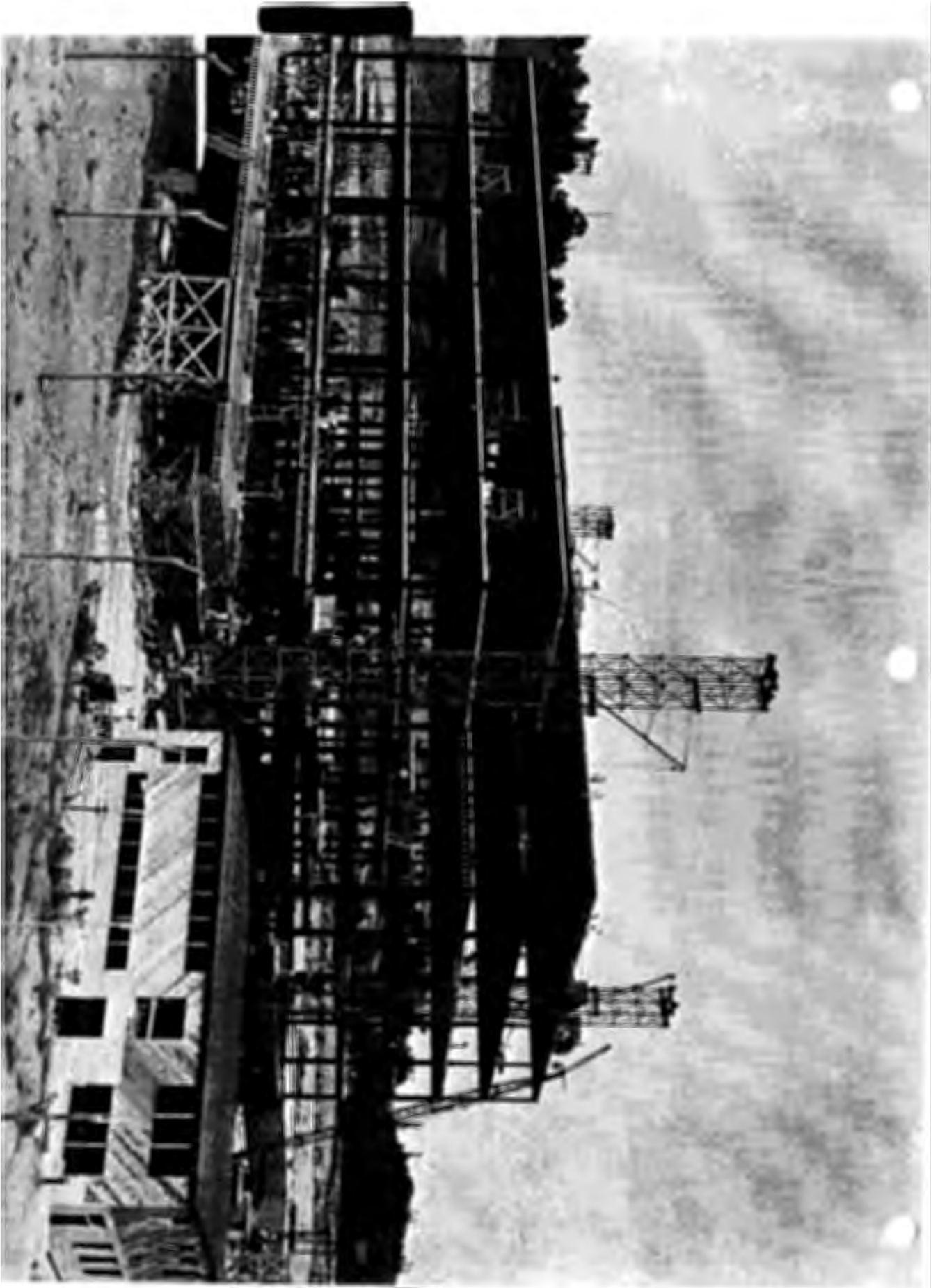



025. Third Beta Process Building 9204-3,

December 1944.



1. The first part of the document discusses the importance of maintaining accurate records of all transactions. This is essential for ensuring the integrity of the financial data and for providing a clear audit trail. The records should be kept up-to-date and should be easily accessible to all relevant parties.

2. The second part of the document focuses on the role of the accounting department in providing timely and accurate financial information to management. This information is crucial for making informed decisions and for identifying areas for improvement. The accounting department should work closely with other departments to ensure that all transactions are properly recorded and reported.

3. The third part of the document addresses the need for strong internal controls to prevent fraud and errors. These controls should be designed to ensure that all transactions are properly authorized and recorded. Regular audits should be conducted to test the effectiveness of these controls and to identify any weaknesses.

4. The fourth part of the document discusses the importance of transparency and communication in financial reporting. Management should provide clear and concise reports to the board and to other stakeholders. This will help to build trust and confidence in the financial statements.

5. The fifth part of the document concludes by emphasizing the need for continuous improvement in financial reporting. The accounting department should regularly review its processes and procedures to ensure that they are up-to-date and effective. This will help to ensure that the financial reporting system remains robust and reliable.

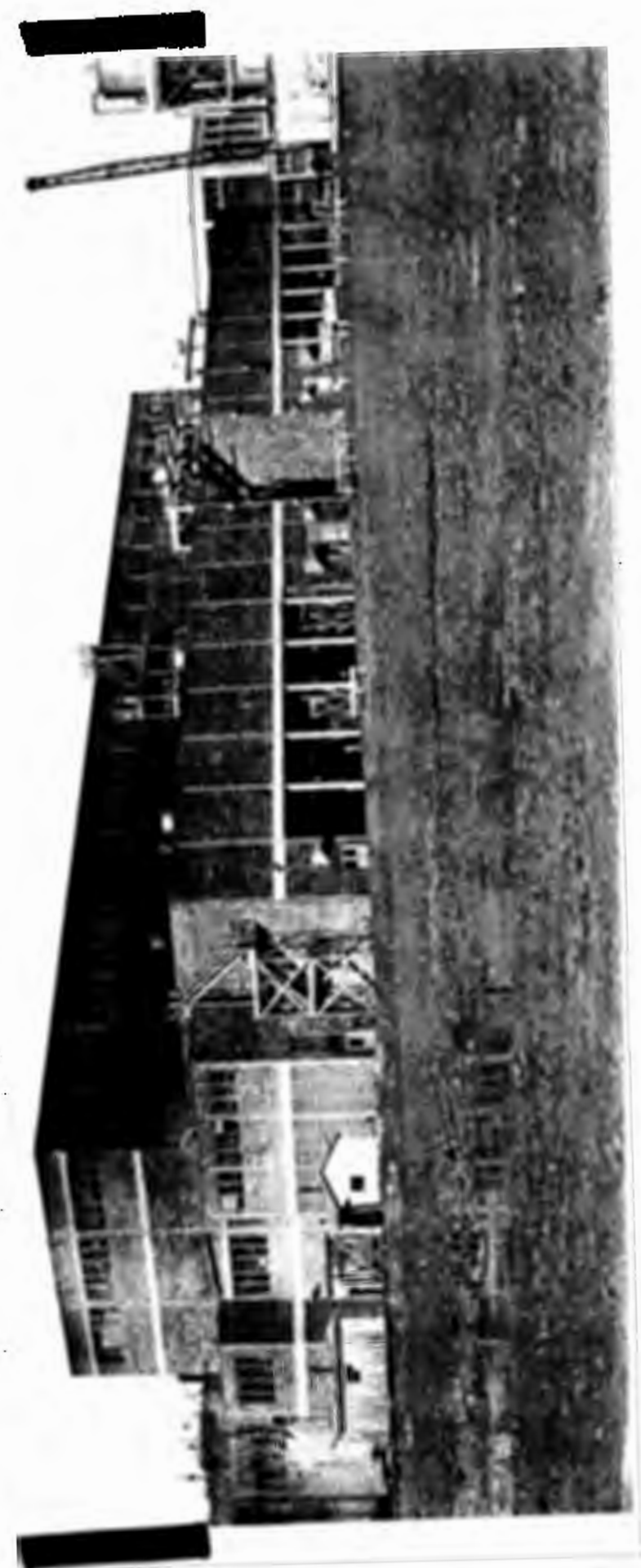



Ch.6. Alpha Chemistry Building 9202

December 1944.



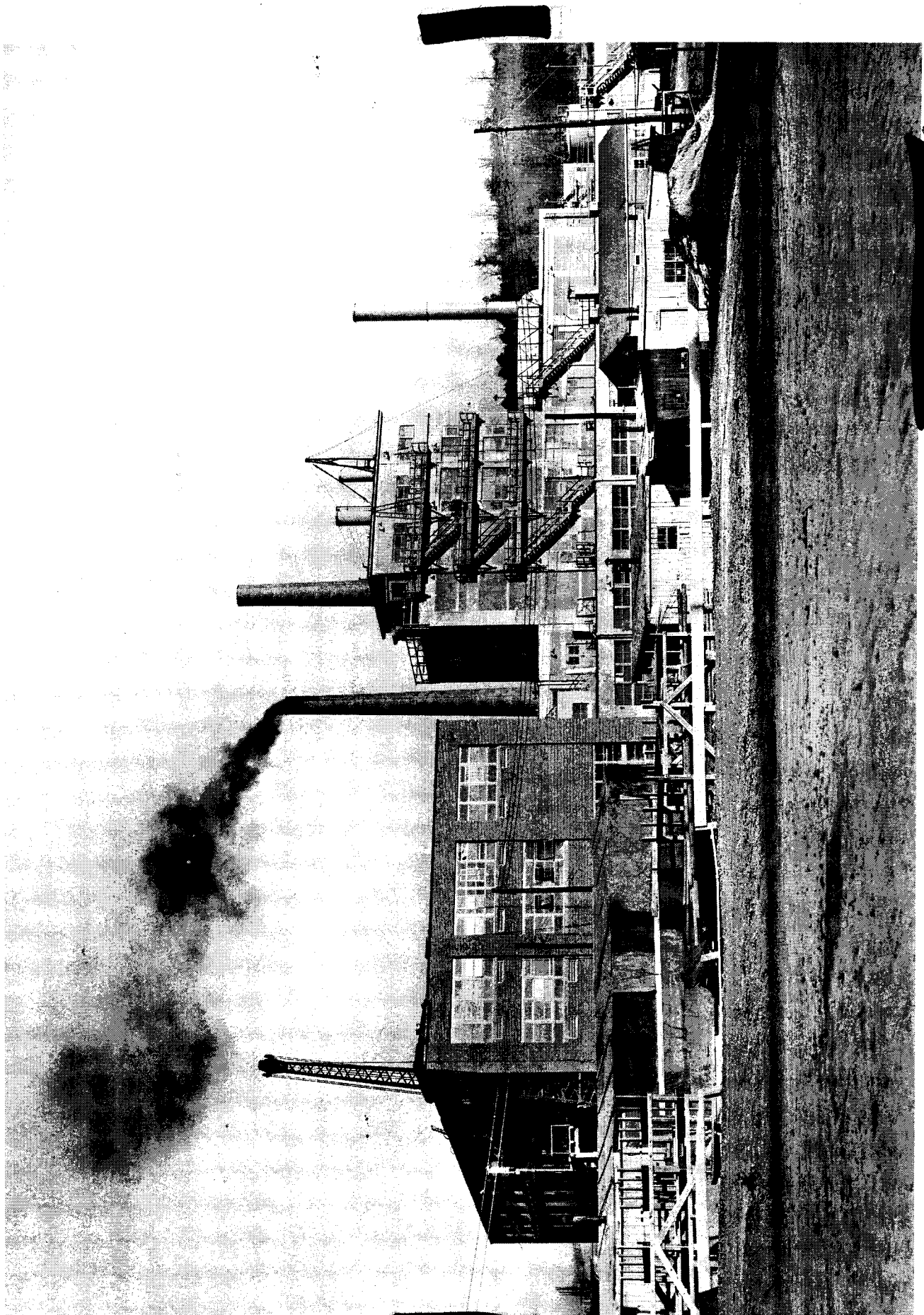



Ch7. Alpha Chemistry Building 9207.

December 1944.



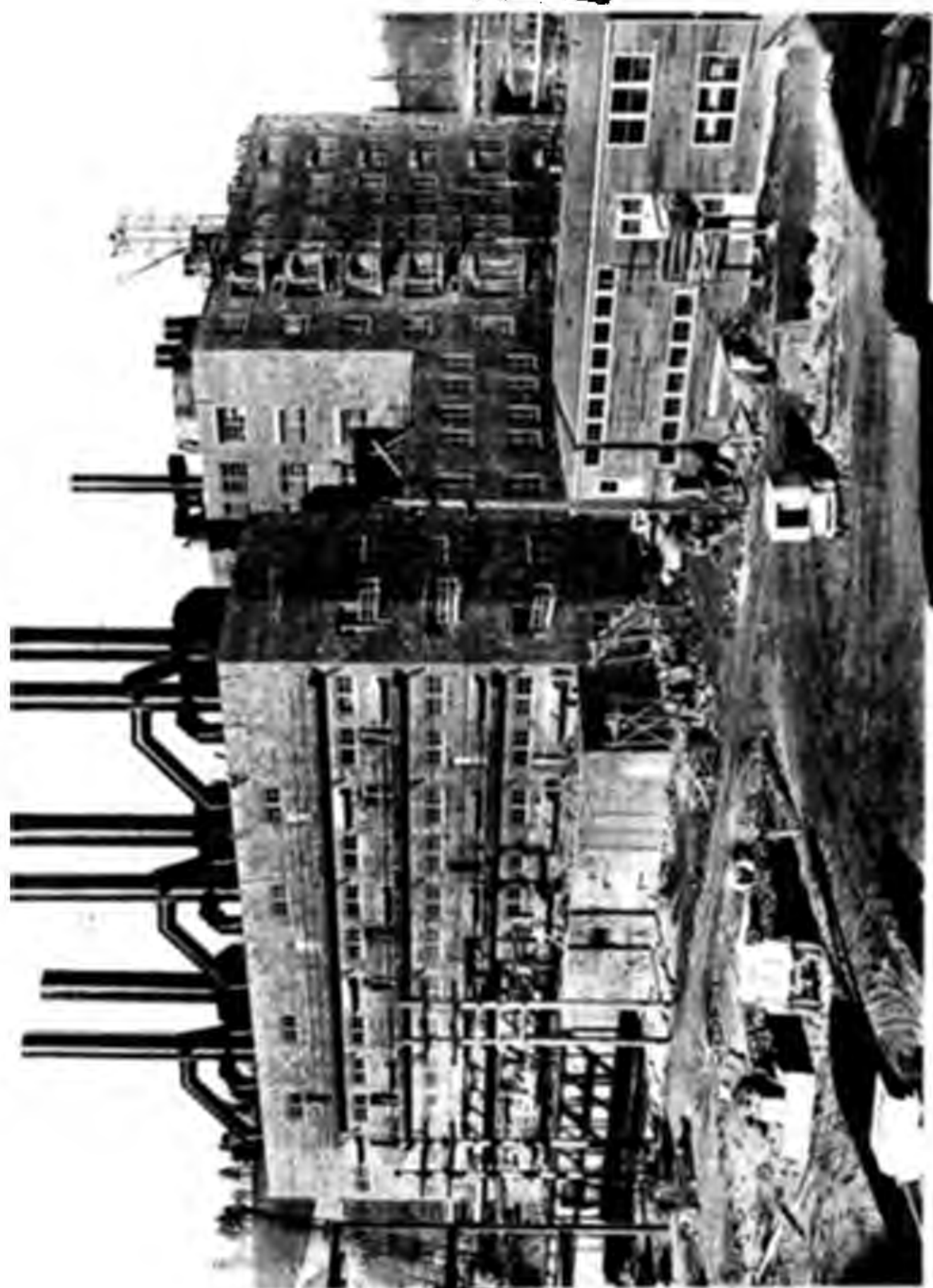

CL3. Some Plant Auxiliaries, March 1945.

In the foreground are Process Development Shops, in the center is one of the Administration Buildings and at the top is the Guard Headquarters. To the left of the Guard Headquarters is a group of Hutments which housed part of the Guard Force.

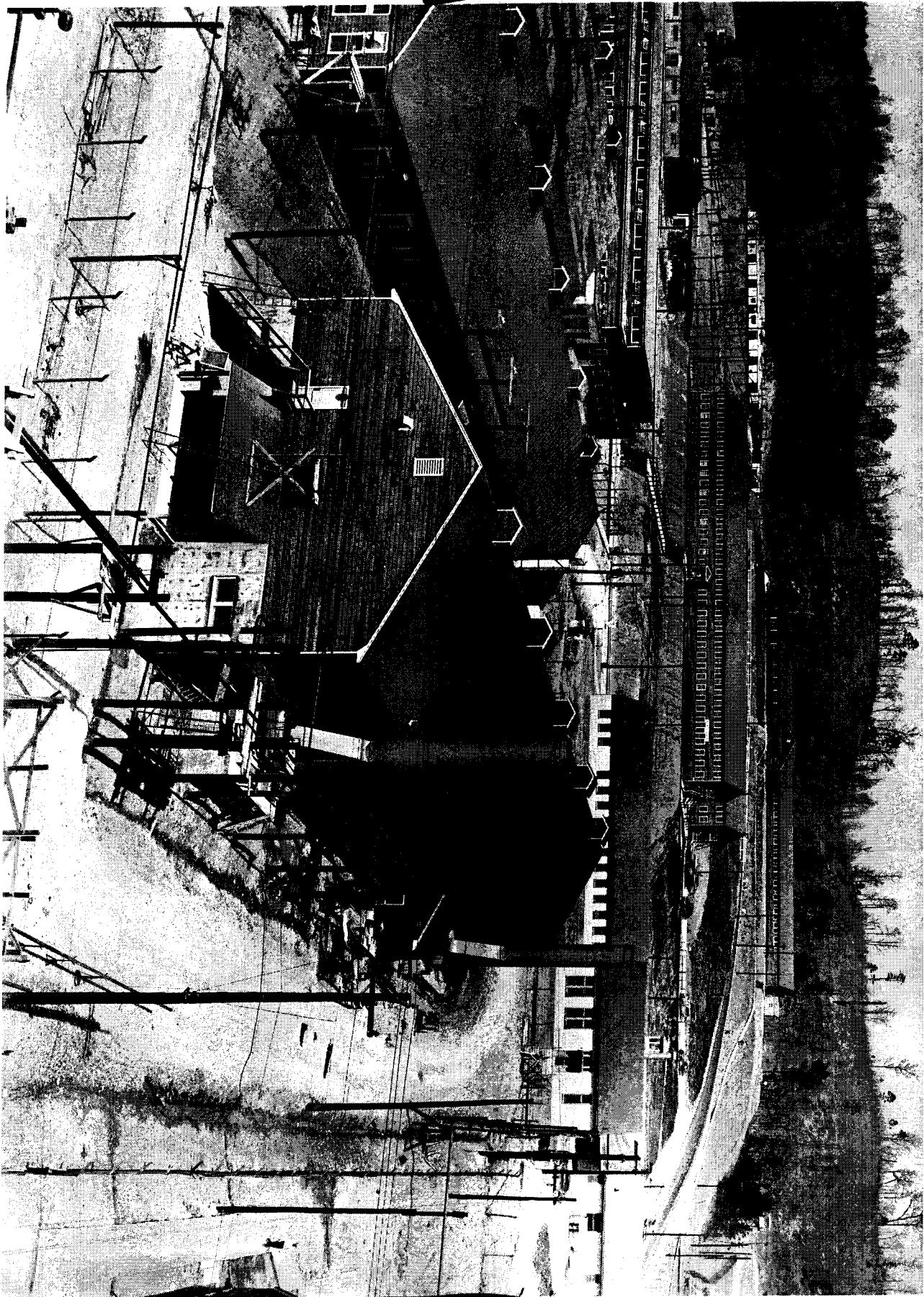



clg. 9207 Chemistry Group, March 1945.





650. Foundation and Partial Steel Frame for
Final Product Building (9212) June 1945.

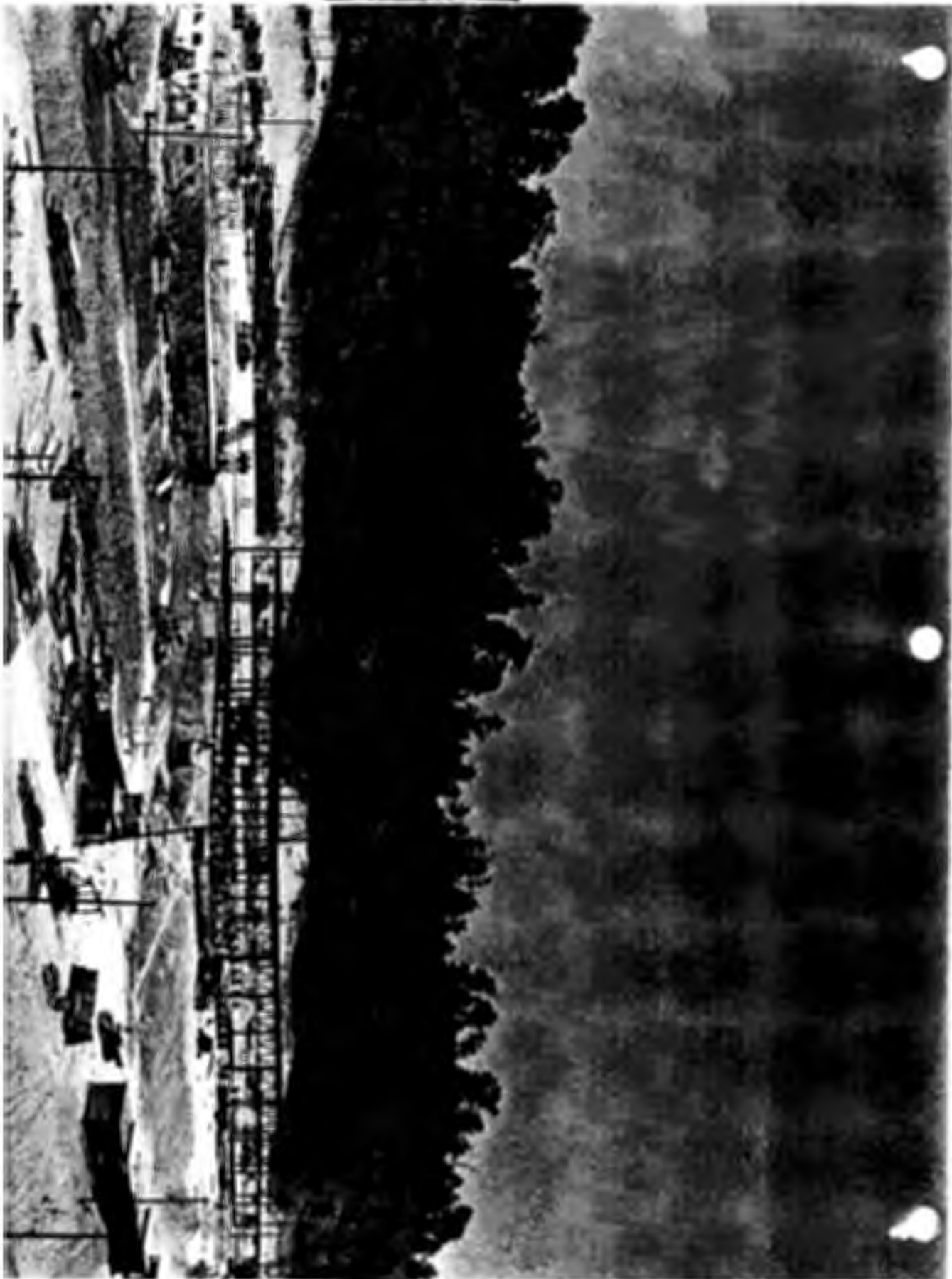

[REDACTED]

051. Aerial View of Y-12 Plant - March 1945.

[REDACTED]





C52. Aerial View of Y-12 Plant - March 1945.





MANHATTAN DISTRICT HISTORY

BOOK V - ELECTROMAGNETIC PROJECT

VOLUME 5 - CONSTRUCTION

APPENDIX "D"

MAPS AND CHARTS

<u>No.</u>	<u>Description</u>
1.	Cost Estimate of Electromagnetic Plant, as of 1 July 1945 <i>January 1947</i> .
2.	Summary of Costs - Electromagnetic Plant, as of 1 July 1945 <i>January 1947</i> .
3.	Government Construction Contracts, as of 1 July 1945 <i>January 1947</i> .
4.	Stone and Webster Engineering Corporation Construction Subcontracts as of 1 July 1945 <i>January 1947</i> .
5.	Stone and Webster Engineering Corporation Construction Purchase Orders, in excess of \$50,000, as of 1 July 1945 <i>January 1947</i> .
6.	Tabulation of Building Statistics.
7.	Map of Perimeter and Interior Fences and Guard Towers.
8.	Map of Water Supply, Oak Ridge, Tennessee.
9.	General Organization Chart, Electromagnetic Plant, Construction.
10.	Stone and Webster Engineering Corporation Key Organization Chart.
11.	Chart of Employees on Payroll - Stone and Webster Engineering Corporation.
12.	Plot Plan of Y-12 and Y-12 Extension.
13.	Map of Clinton Engineer Works Reservation showing Electromagnetic Project.
14.	Safety Section Organization Chart.
15.	Tabulation of Temporary Buildings for Y-12 and Y-12 Extension.

Appendix D1

COST ESTIMATE OF ELECTRO MAGNETIC PLANT

January 1947.
AS OF 1 JULY 1945

SECRET

COST ESTIMATE OF ELECTROMAGNETIC PLANT

JANUARY 1947.

As Of 1 JULY 1947

<u>Building</u>	<u>Y-12</u>	<u>Y-12 Ext.</u>	<u>J.O. 7553 & J.O. 7558</u>	<u>Total</u>
9201-1 Alpha No. 1	\$ 29,081,000	\$	\$	\$ 29,081,000
9201-2 " No. 2	26,554,500			26,554,500
9201-3 " No. 3	19,310,600		562	19,311,162
9201-4 " No. 4		14,014,800	43,560	14,058,360
9201-5 " No. 5		42,557,200	31,669	42,588,869
9202 Chemistry A	4,432,500		378,140	4,810,640
9203 " B	755,400		2,000	757,400
9204-1 Beta No. 1	15,701,400		7,993	15,709,393
9204-2 " No. 2		16,379,800	26,225	16,406,025
9204-3 " No. 3		15,893,500	29,175	15,922,675
9204-4 " No. 4			18,164,000	18,164,000
9205 Analysis Laboratory	85,400		1,617	87,017
9206 No. 2 Process Chemistry Building		4,289,000	334,806	4,623,806
9207 No. 1 " "		12,080,300		12,080,300
9208 Chemical Storage Building		610,000		610,000
9209 Beta Salvage Bldg. No. 2		21,200		21,200
9210 Vacuum Process Building		5,848,600		5,848,600
9211 Special Material Conversion		1,394,400		1,394,400
9212 Chemistry Building			4,930,000	4,930,000
9401-1 #2 Boiler Houses	1,386,300	1,236,000	17,000	2,639,300
9401-1 Water Pump House for 9201-1	125,100			125,100
9401-2 " " " " "	113,900			113,900
9401-3 " " " " 9201-2	136,800			136,800
9401-4 " " " " "	123,200			123,200
9401-5 " " " " 9201-3	146,600			146,600

D1

SECRET

BuildingY-12Y-12 Ext.J.O. 7533 *
J.O. 7558Total

9404-6 Water Pump House for 9731	\$ 14,200	\$	\$	\$ 14,200
9404-7 " " " " 9204-1	64,200			64,200
9404-8 " " " " 9204-1	58,500			58,500
9404-9 " " " " 9204-2			133,300	133,300
9404-10 " " " " 9204-2			104,900	104,900
9404-11 " " " " 9201-4			65,000	65,000
9404-12 " " " " 9201-4			59,600	59,600
9404-13 " " " " 9201-5			49,000	49,000
9404-14 " " " " 9201-5			55,400	55,400
9404-15 " " " " 9202	1,200			1,200
9409-1 Water Cooling Tower for 9201-1	290,600			290,600
9409-2 " " " " 9201-1	272,700			272,700
9409-3 " " " " 9201-2	226,500			226,500
9409-4 " " " " 9201-2	219,600			219,600
9409-5 " " " " 9201-3	244,300			244,300
9409-6 " " " " 9731	58,200			58,200
9409-7 " " " " 9204-1	110,500			110,500
9409-8 " " " " 9204	102,100			102,100
9409-9 " " " " 9204-2			129,600	129,600
9409-10 " " " " 9204			122,200	122,200
9409-11 " " " " 9201-4			170,000	170,000
9409-12 " " " " 9201-4			181,900	181,900
9409-13 " " " " 9201-5			172,600	172,600
9409-14 " " " " 9201-5			161,000	161,000
9409-15 " " " " 9204-3			35,400	35,400
9409-16 " " " " 9204-3			39,800	39,800
9409-17 " " " " 9762			31,400	31,400
9409-18 " " " " 9202	39,200			39,200
9409-19 " " " " 9207			73,000	73,000
9413 Water Supply Main				
9415 Distilled Water Plant	20,500			20,500
9416 Treating House	40,400		49,200	89,600
9418 Clean Oil Tanks	52,200			52,200

D1

<u>Building</u>	<u>Y-12</u>	<u>Y-12 Ext.</u>	<u>J.O. 7533 & J.O. 7558</u>	<u>Total</u>
9419 Distilled Water Preparation	\$ 24,100	\$ 1,000	\$	\$ 25,100
9420 Distilled Water Pump House		331,300		331,300
9501 Electric Sub-station	528,400	658,500	636,250	1,823,150
9502 Steam Distribution	704,600	405,900		1,110,500
9503 Water Distribution	606,600	563,600	310,000	1,480,200
9504 Sewage and Waste Disposal	325,800	322,600		648,400
9507 Drainage	411,400	348,500		759,900
9510 Process Waste Disposal		17,300		17,300
9512 Electrical Distribution	288,300	201,100	1,000	490,400
9601 Railroad	109,400	100,000		209,400
9602 Roads and Walks	487,000	321,400	185,989	994,389
9603 Fence and Guard Towers			65,000	65,000
9605 Autos, Tractors, and Trailers	17,800	2,200		20,000
9609 Oil Pump House	8,400	4,300		12,700
9610 Oil Storage House	39,500			39,500
9612 Grading	332,300	476,700		809,000
9616 Caustic Unloading Station	60,000	455,500		515,500
9620 Oil Purification	123,900	51,700		175,600
9621 Hydrolysis Tower		178,900		178,900
9701 Examination Building	316,900	126,200	6,925	450,025
9702 Telephone Building	15,100	5,500		20,600
9703 Gate House	5,000			5,000
9704 Administration Building	421,000		5,650	426,650
9705 Guard Headquarters	163,900			163,900
9706 Medical Service Building	371,900		45,000	416,900
9709 Shop	869,700			869,700
9710 Fire Headquarters	50,800	57,800		108,600
9711 Cafeteria	459,500	862,500	66,895	1,388,895
9712 Garage and Repair Shop	156,400			156,400
9713 Highway Crossover	3,600			3,600
9720 Warehouse	413,900	302,000	351,500	1,067,400
9722 Clock Alley	13,600			13,600
9723 Change Houses	1,336,500	1,264,800	57,500	2,658,800
9727 Liquid Nitrogen Storage	24,900			24,900

01

SECRET

<u>Building</u>	<u>Y-12</u>	<u>Y-12 Ext.</u>	<u>J.O. 7533</u> <u>J.O. 7558</u>	<u>Total</u>
9728 Laundry	\$ 222,500		\$	\$ 222,500
9729 Dry Ice Storage	60,000			60,000
9731 Pilot Plant	3,073,100			3,073,100
9732 Acetone Building	67,700			67,700
9733 Chemistry Process Development	248,000	833,800	20,726	1,102,526
9734 Engineering Process Development	152,100			152,100
9735 Physics Process Development	198,700			198,700
9736 Shop Process Development	152,900			152,900
9737 Electrical Main. Shop	215,100		45,000	260,100
9738 Foundry	150,700		25,000	175,700
9739 Engineering	176,900			176,900
9740 Solvent Building	16,500			16,500
9741 Generator Building	12,600			12,600
9743 Ammonia Storage	12,200	53,200		65,400
9744 Electroplating Building		300,800	750	301,550
9745 Barracks	53,300			53,300
9747 Wash House	16,000			16,000
9752 Refrigerator Building	23,300			23,300
9753 Automotive Service	38,000			38,000
9754 Service Station	32,600			32,600
9755 Grease Rack	71,000			71,000
9756 Gas Cylinder Storage	12,800			12,800
9764 Paymasters Building	15,100			15,100
9766 Laboratory Process Development	272,200		200	272,400
9767 Compressor Building (9206)		276,300		276,300
9768 Fan House (9206)		93,500		93,500
9769 Incinerator (9207)		357,000		357,000
9770 Sampling House (9207)		8,000		8,000
9771 Cold Storage Building			30,000	30,000
Miscellaneous	418,900		5,337,168	5,756,068
Machine Shop			1,060,000	1,060,000
	\$ 114,200,000	\$ 155,000,000	\$ 32,211,600	\$ 301,411,600

D1

SECRET

APPENDIX D2
ELECTROMAGNETIC PLANT

SUMMARY OF COSTS
JANUARY 1947
AS OF 1 JULY 1945

ELECTROMAGNETIC PLANT

. SUMMARY OF COSTS

AS OF 1 JANUARY 1947

COST OF CONSTRUCTION

**Number of
Transactions**

23 Government Contracts (App. D3)	\$.	8,388,715.27
38 Stone and Webster Subcontracts (App. D4)		22,964,374.84
21 Stone and Webster Orders Over \$50,000(App. D5)		2,302,467.56
Remaining Orders of Less than \$50,000		12,569,021.60
	\$	<u>46,724,579.27</u>
Construction Work Performed by Stone and Webster's Own Forces		118,239,523.23
Cost of Construction	\$	<u>164,964,102.50</u>

Total Cost of Electromagnetic Plant

Cost of Construction		164,964,102.50
Cost of Equipment (Volume 3, Book V)		136,447,497.50
	\$	<u>301,411,600.00</u>
<u>Direct Plant Cost (App. D1)</u>		301,411,600.00
Cost of Design (Volume 3, Book V)		5,619,300.00
Silver Program (Volume 4, Book V)		2,432,626.00
Fees (Volume 1, Book V)	\$	<u>3,384,879.00</u>
<u>Total Cost of Electromagnetic Plant</u>	\$	<u>312,898,705.00</u>



APPENDIX D3

GOVERNMENT CONSTRUCTION CONTRACTS

JANUARY 1947
AS OF 1 JULY 1945



~~XXXXXXXXXX~~

GOVERNMENT CONSTRUCTION CONTRACTS

AS OF 1 JULY 1945 *JANUARY 1947*

Contract Number	Type Contract	Date Contract	Contractor	Contractor's Address	Scope of Work	Contract Amount
<u>Prime Contract Number W-7401-eng-13</u>						
W-7421-eng-1	WD#1	12-26-42	Humphrey & O'Connor	Knoxville, Tenn.	Plumbing & Heating	\$ 18,050.44
W-7421-eng-2	"	1-22-43	Broadway Maintenance	New York, N.Y.	Electrical Work	4,175.25
W-7405-eng-308	"	5-11-44	Bethlehem Steel Co.	Boston, Mass.	Str. Steel 9204-3, etc.	492,726.88
W-7421-eng-6	WD#2	11-16-43	Bristol Steel & Iron Co.	Bristol, Va. Tennessee	Str. Steel 9201-4-5	331,006.30
W-7401-eng-174	"	4-10-44	Brooks-Fisher Insulation Co.	Atlanta, Ga.	Insulation Work	545,880.17
W-7423-eng-1	"	6-12-43	Drainage Contractors	Detroit, Mich.	Sewer & Water Lines	347,850.81
W-7418-eng-1	"	11-25-42	Harrison Const. Co.	Pittsburgh, Pa.	Clearing, Grubbing & Excavtg.	1,989,422.43
W-7407-eng-14	WD#1	2-5-43	Rockwood Sprinkler Co.	Boston, Mass.	Fire Protection Y-12	230,668.21
W-7407-eng-38	"	1-13-44	Rockwood Sprinkler Co.	Boston, Mass.	Fire Protection Y-12 Ext.	181,781.00
W-7418-eng-3	"	12-15-42	Ralph Rogers Co.	Nashville, Tenn.	Crushed Stone	337,728.00
W-7418-eng-66	"	12-22-43	Ralph Rogers Co.	Nashville, Tenn.	Crushed Stone	212,244.66
W-7401-eng-164	WD#2	3-3-44	C. O. Struss & Sons	Philadelphia, Pa.	Masonry-Y-12 Ex.	905,674.00
W-7418-eng-4	WD#1	12-17-42	Transit Mix Concrete Corp.	New York, N.Y.	Concrete	1,975,627.73
W-7423-eng-7	"	2-23-44	Asbestos Erectors	Bound Brook, N.J.	Corr. Asbestos Siding	29,758.76
<u>Subtotal</u>						<u>\$ 7,602,594.64</u>

D3

JUL 1945

Contract Number	Type of Contract	Date Contract	Contractor	Contractor's Address	Scope of Work	Contract Amount
<u>Prime Contract Number W-114-108-eng-49</u>						
W-22-075-eng-82	WD#1	4-20-45	Bethlehem Steel Co.	Bethlehem, Pa.	Structural Steel	\$ 101,501.35
W-22-075-eng-81	"	4-20-45	Carrier Corporation	Syracuse, N.Y.	Refrigeration	146,432.00
W-22-075-eng-130	"	6-12-45	Rockwood Sprinkler Co.	Worcester, Mass.	Fire Protection	50,000.00
W-22-075-eng-88	WD#2	5-7-45	C. O. Struss & Sons	Philadelphia, Pa.	Masonry	90,000.00
<u>Subtotal</u>						\$ 387,933.35

Prime Contract Number W-114-108-eng-60

W-22-075-eng-88	WD#2	5-7-45	C. O. Struss & Sons	Philadelphia, Pa.	Masonry	105,565.00
W-22-075-eng-69	WD#1	4-2-45	Bethlehem Steel Co.	Bethlehem, Pa.	Structural Steel	158,208.17
W-22-075-eng-73	"	4-10-45	Truseen Laboratories	Detroit, Mich.	Roof Decking	32,542.00
W-22-075-eng-70	"	4-2-45	Rockwood Sprinkler Co.	Worcester, Mass.	Fire Protection	36,872.11
W-114-108-eng-66	"	6-1-45	Armor Insulating Co.	Atlanta, Georgia	Insulation	65,000.00
<u>Subtotal</u>						\$ 398,187.28

Total Construction Contracts

\$ 8,388,715.27

JUL 1945

~~SECRET~~

APPENDIX D1
STONE AND WEBSTER ENGINEERING CORPORATION
CONSTRUCTION SUBCONTRACTS
AS OF 1 JULY 1945
JANUARY 1947

~~SECRET~~

STONE & WEBSTER ENGINEERING CORPORATION
CONSTRUCTION SUBCONTRACTS
AS OF 1 JULY 1945 JANUARY 1947

Subcontract Number	Date of Subcontract	Subcontractor	Scope of Work	Amount of Subcontract
<u>Prime Contract Number W-7401-eng-13</u>				
6-C-2706	11-23-42	Giles Drilling Corp.	Test Borings and Drilling Hydraulic Elevator Plunger Holes	\$ 100,299.61
7-C-3101	1- 9-43	Tennessee Roofing Co.	Roofing	98,197.85
12-C-2390	3-26-43	Alphons Custodia Chimney Co.	Radial Brick Chimney	11,044.00
14-C-4881	4- 1-43	General Elevator Co.	Hydraulic Elevators	52,166.00
18-C-652	2-27-43	York Ice Machinery Corp.	Refrigeration Equipment	1,432.00
19-C-677	2-27-43	York Ice Machinery Corp.	Air Conditioning Equipment	4,690.00
20-C-729	3-17-43	Morris Brothers	Boiler Setting	12,102.65
23-C-979	4-24-43	Jehn Van Range Co.	Cafeteria Equipment	19,426.30
25-C-4882	4-26-43	Morris Forge & Drilling Co.	Drilling Hydraulic Elevator Plunger Holes	5,410.00
26-C-919	4-14-43	Buffalo Tank Corporation	Steel Tanks	33,474.00
28-C-4885	5-11-43	General Elevator Co.	Electric Elevators	13,050.00
30-C-5724	5-15-43	Roy C. Smith Tile Co.	Linoleum and Asphalt Tile Floors	456.50
32-C-5723	5-14-43	Sewanee Coal & Supply Co.	Cold Storage Insulation-	4,385.00
33-C-5725	5-13-43	E. F. Hauserman Company	Movable Partitions	7,186.45
34-C-437	2- 4-43	Link-Belt Company	Coal Handling Equipment	24,752.36

Subcontract Number	Date of Subcontract	Subcontractor	Scope of Work	Amount of Subcontract
<u>Prime Contract Number W-7401-eng-13 (Cont.)</u>				
35-C-6221	5-25-43	John Beretta Tile Company	Asphalt Tile Floors	\$ 3,416.64
42-C-6227	6-15-43	Tennessee Roofing Company	Roofing	74,607.85
43-C-6228	5-28-43	Watson-Flagg Eng. Company	Electrical Installation Work	11,988,685.00
45-C-6230	6-29-43	General Elevator Company	Electric Sidewalk Elevators	21,400.00
46-C-6231	6-23-43	Pittsburgh Plate Glass Co.	Glass and Glazing	28,821.19
51-C-6236	7-20-43	Tri-State Asbestos Company	Insulation of piping and Equipment	322,528.22
53-C-6238	7-21-43	Johns-Manville Sales Corp.	Acid Proof Mastic Floors	1,854.75
54-C-1658	7-13-43	United Conveyor Corp.	Ash Handling Equipment	12,309.00
55-C-7606	7-21-43	Ruland Gas Company	Gas Storage Tanks	5,150.02
56-C-6239	8-5-43	Swain & Myers, Inc.	Lunch Room Equipment	4,413.75
59-C-1875	8-12-43	Norris Brothers	Refractory Boiler Settings	12,290.00
61-C-9804	9-15-43	Kirk & Vlum Mfg. Co.	Equipment Exhaust System	12,407.00
64-C-50047	11-4-43	Chattanooga Boiler & Tank Co.	Steel Tanks	41,801.50
65-C-50077	11-13-43	William G. Solt	Refractory Boiler Settings	67,556.00
66-C-50076	11-13-43	Link-Belt Company	Coal Handling System	39,987.24



Subcontract Number	Date of Contract	Subcontractor	Scope of Work	Amount of Subcontract
--------------------	------------------	---------------	---------------	-----------------------

Prime Contract Number W-7401-eng-13 (Cont.)

67-C-50081	11-15-43	United Conveyor Corp.	Ash Handling Equipment	\$ 17,053.50
69-C-50217	11-27-43	Truscon Laboratories	Cement Tile Roof Decking	195,530.26
73-C-9811	12-14-43	R. Doughty Sons Co., Inc.	Dismantle & Re-erect Boilers	64,575.00
74-C-9812	12-18-43	Tennessee Roofing Company	Roofing	14,444.15
77-C-9815	12-30-43	Decatur Iron & Steel Company	Structural Steel	37,812.24
78-C-9816	12-22-43	Consolidated Chimney Company	Radial Brick Chimney	10,160.00
79-C-50318	1-10-44	Greaver Tank & Mfg. Company	Tanks	7,804.00
80-C-9817	1-18-44	General Elevator Company	Freight Elevators	36,486.36
83-C-9820	1-14-44	Hanley and Company	Piping Installation Work	7,417,858.00
84-C-52541	2-9-44	J. G. Wilson Corp.	Rolling Steel Doors	13,228.00
85-C-52542	2-11-44	Sewanee Coal & Supply Co.	Roofing	121,713.12
89-C-50649	4-1-44	John Van Range Company	Cafeteria Equipment	66,227.88
91-C-52543	4-18-44	General Elevator Company	Electric Freight Elevator	2,795.00
92-C-52544	4-18-44	Armstrong Cork Company	Cold Storage Insulation	11,548.38
94-C-52545	4-18-44	Warner Elevator Mfg. Co.	Dumbwaiters	4,652.00





Subcontract Number	Date of Subcontract	Subcontractor	Scope of Work	Amount of Subcontract
<u>Prime Contract Number W-7401-eng-13 (Cont.)</u>				
96-C-52546	4-25-44	General Elevator Company	Hydraulic Elevator	\$ 10,340.86
98-C-52547	5-2-44	Warner Elevator Mfg. Company	Dumbwaiters	2,230.00
99-C-50785	5-3-44	York Ice Machinery Corp.	Cafeteria Refrigeration	16,947.91
100-C-50764	5-4-44	Market Forge Company	Refrigerator Shelving, Mono-Rail and Scales	8,540.00
101-C-17686	4-28-44	Giles Drilling Corp.	Drilling Hydraulic Elevator Plunger Hole	2,439.00
102-C-17687	5-5-44	General Elevator Company	Hydraulic Elevator	4,125.00
103-C-50878	5-11-44	National Fireproofing Corp.	Coal Silos	15,063.60
108-C-17690	6-13-44	Pittsburgh Plate Glass Co.	Glass and Glazing	1,776.97
114-C-20064	6-30-44	Carrier Corporation	Package Refrigeration	17,928.00
116-C-52549	7-10-44	General Elevator Company	Freight Elevators	33,740.00
117-C-52550	7-21-44	Warsaw Elevator Company	Dumbwaiters	97,922.14
119-C-51388	7-11-44	Carrier Corporation	Package Refrigeration	17,227.00
121-C-17698	8-30-44	Alphons Custodis Chimney Co.	Radial Brick Chimney	11,324.00

70





Subcontract Number	Date of Subcontract	Subcontractor	Scope of Work	Amount of Subcontractor
--------------------	---------------------	---------------	---------------	-------------------------

Prime Contract Number W-7401-eng-13 (Cont.)

122-C-20195	7-7-44	Link-Belt Company	Coal Handling Equipment	\$ 23,125.00
124-C-20300	8-25-44	United Conveyor Corp.	Ash Handling Equipment	5,230.00
125-C-52551	9-14-44	Tennessee Roofing Company	Roofing	52,451.00
126-C-52552	11-3-44	Consolidated Chimney Co.	Radial Brick Chimney	<u>6,240.00</u>
			Subtotal	\$21,374,069.55

DL

Prime Contract Number W-14-108-eng-19

1-C-30210	2-22-45	Brooks-Fisher Insulating Co.	Insulation of Piping Equipment	\$ 117,958.04
2-C-31588	5-7-45	H. E. Anning Company	Sheetrock Pyrofill Roof Decking	18,027.99
3-C-32083	6-12-45	Tennessee Roofing Company	Roofing	<u>30,169.82</u>
			Subtotal	\$ 166,155.85

Prime Contract Number W-14-108-eng-60

1-F-40204	4-7-45	Watson-Flagg Engineering Co.	Electrical Installation Work	\$ 733,513.44
2-F-40227	4-7-45	Hanley & Company	Piping Installation Work	672,850.00
3-C-40288	5-16-45	Tennessee Roofing Company	Roofing	<u>17,456.00</u>
			Subtotal	\$1,423,819.44

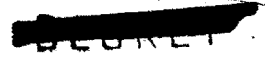

Total Construction Subcontracts \$ 22,964,374.84



APPENDIX D5

STONE & WEBSTER ENGINEERING CORPORATION

CONSTRUCTION PURCHASE ORDERS

IN EXCESS OF \$50,000

AS OF 1 ^{JANUARY 1947}~~JULY 1945~~



~~SECRET~~

STONE & WEBB ENGINEERING CORP.
CONSTRUCTION PURCHASE ORDERS
IN EXCESS OF \$50,000
AS OF 1 JULY 1945 *JANUARY 1947*

Number	Type of Contract	Date of Contract	Contractor	Cont.'s Add.	Scope of Work	Cost of Work
<u>Prime Contract Number W-7401-eng-13</u>						\$
915	Order	4-17-43	American Bridge Co.	Boston, Mass.	Roof Steel	99,118.45
52635	Order	3-22-44	American Bridge Co.	Boston, Mass.	Str. Steel	52,000.00
50008	Order	10-2-43	Bristol Steel & Iron Works	Bristol, Va.	Str. Steel Framing	307,048.88
52203	Order	11-24-43	Bristol Steel & Iron Works	Bristol, Va.	Str. Steel	299,210.17
52792	Order	3-17-44	Butler, Geo. Co.	Chicago, Ill.	Unistrut & Fittings	79,805.25
53255	Order	5-2-44	Butler, Geo. Co.	Chicago, Ill.	Unistrut & Fittings	60,577.76
52146	Order	1-7-44	Coleman, Ollie Brick Sales Co.	Knox., Tenn.	Building File	128,423.48
53447	Order	5-16-44	Electrical Wholesale, Inc.	Atlanta, Ga.	Conduit & Fittings	68,940.28
52343	Order	12-27-43	Group, Henry E. Co.	Chicago, Ill.	Str. Steel	299,851.34
52001	Order	9-28-43	Harbor Plywood Corp	Hoquiam, Wash.	500,000 sq.ft. Plywood	62,400.00
260	Order	1-11-43	Manning, Maxwell & Moore, Inc.	Muskegon, Mich.	20-ton Cranes	78,028.90
474	Order	2-5-43	Shaw Box Crane & Hoist Div. Manning, Maxwell & Moore, Inc.	Boston, Mass.	Traveling Cranes	91,805.00
6364	Order	5-21-43	National Cylinder Gas Co.	Knox., Tenn.	Requirements of Oxygen	100,000.00
51466	Order	8-4-44	Trane Co., The	Boston, Mass.	Heating & Ventilating Units	50,364.40

05

~~SECRET~~



Number	Type of Contract	Date of Contract	Contractor	Contractor's Address	Scope of Work	Cost of Work
<u>Prime Contract Number W-7401-eng-13(Contd.)</u>						
50085	Order	11-16-43	U.S. Pipe & Foundry Co.	Boston, Mass.	C.I. Pipe & Fittings	\$ 93,493.35
52002	Order	9-28-43	Weyerhouser Sales Co.	New Orleans, La.	500,000 sq.ft. Plywood	66,555.30
50004	Order	9-28-43	Whiting Corp.	New York, N.Y.	Traveling Cranes	255,070.00
6560	Order	5-31-43	Wilson-Weesner-Wilkinson Co.	Knoxville, Tennessee	Reinforcing Steel	70,190.00
52182	Order	11- 8-43	Wilson-Weesner-Wilkinson Co.	Knoxville, Tennessee	Reinforcing Steel	270,000.00
<u>Subtotal</u>						<u>\$ 2,193,162.56</u>
<u>Prime Contract Number W-14-108-eng-19</u>						
31810	Order	6- 8-45	General Electric	Boston, Mass.	Indoor Pyronal Capacitor Equip.	215,675.00
31805	Order	6- 9-45	Westinghouse Elect.	Boston, Mass.	Circuit Breakers	63,630.00
<u>Subtotal</u>						<u>\$ 309,305.00</u>
<u>Total Construction Purchase Orders</u>						<u>\$ 2,802,467.56</u>

D5

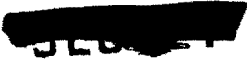

~~SECRET~~

ION OF BUILDING STATISTICS

FLOOR AREA (Sq. Ft.)	CUBE (Cu. Ft.)	BASEMENT	No. FLOORS	FOOTINGS	FOUNDATION PIERS	TYPE FRAME	EXT. WALLS	INT. WALLS	ROOF DECK	ROOFING	FLOOR
9440	671,125	0	2	CONC.	CONC.	CONC.	BRICK	STRUCT.TILE	CONC.	TAR&GRAVEL	CONC.
"	"	"	"	"	"	"	"	"	"	"	"
1,955	384,733	0	3	CONC.	CONC.	CONC.	STRUCT.TILE	STRUCT.TILE	CONC.	TAR&GRAVEL	CONC.
9,144	621,889	0	4	CONC.	CONC.	CONC.	BRICK	STRUCT.TILE	CONC.	TAR&GRAVEL	CONC.
5,830	547,668	0	3	CONC.	CONC.	STRUCT. STEEL	BRICK	STRUCT.TILE	PRE-CAST CONC.	TAR&GRAVEL	CONC.
4,008	257,192	0	2	CONC.	CONC.	CONC.	CONC.	STRUCT.TILE	CONC.	TAR&GRAVEL	CONC.
6,958	531,642	0	2	CONC.	CONC.	CONC.	BRICK	STRUCT.TILE	CONC.	TAR&GRAVEL	CONC.
1,685	32,400	0	1	CONC.	CONC.	CONC.	CONC.	STRUCT.TILE	CONC.	TAR&GRAVEL	CONC.
1,660	422,737	0	1	CONC.	CONC.	BRICK	BRICK	BRICK	PRE-CAST CONC.	TAR&GRAVEL ASPH. SHINGLE	CONC.
4,186	89,592	0	1	CONC.	CONC.	BRICK	BRICK	BRICK	WOOD	TAR&GRAVEL	CONC.
"	"	"	"	"	"	"	"	"	"	"	"
5,014	106,970	0	1	CONC.	CONC.	BRICK	BRICK	BRICK	WOOD&CONC.	"	CONC.
"	"	"	"	"	"	"	"	"	"	"	"
5,198	139,102	0	1	CONC.	CONC.	BRICK	BRICK	BRICK	WOOD&CONC.	"	CONC.
657	14,200	0	1	CONC.	CONC.	BRICK	BRICK	BRICK	WOOD	ASPH. SHINGLE	CONC.
2,714	56,825	0	1	CONC.	CONC.	BRICK	BRICK	BRICK	WOOD&CONC.	ASPH. SHINGLE	CONC.
"	"	"	"	"	"	"	"	"	"	"	"
176	1,940	0	1	CONC.	0	WOOD	NOV. SIDING	0	WOOD	ASPH. SHINGLE	CONC.
7,650	0	0	TANK ONLY	CONC.	0	0	CONC.	0	0	0	CONC.
"	"	"	"	"	"	"	"	"	"	"	"
"	"	"	"	"	"	"	"	"	"	"	"
"	"	"	"	"	"	"	"	"	"	"	"
"	"	"	"	"	"	"	"	"	"	"	"
1,648	"	"	"	"	"	"	"	"	"	"	"
2,105	"	"	"	"	"	"	"	"	"	"	"
"	"	"	"	"	"	"	"	"	"	"	"
1,067	"	"	"	"	"	"	"	"	"	"	"
"	"	"	TANKS	"	"	CONC.	CONC.	"	"	"	CONC.
238	3,487	0	1	CONC.	0	WOOD	NOV. SIDING	0	WOOD	ASPH. SHINGLE	CONC.
"	"	"	"	"	"	"	"	"	"	"	"
"	"	"	"	"	"	"	"	"	"	"	"
206	3,119	"	"	"	"	"	"	"	"	"	"
238	3,487	"	"	"	"	"	"	"	"	"	"
357	4,257	0	1	CONC.	0	WOOD	NOV. SIDING	0	WOOD	ASPH. SHINGLE	CONC.
"	"	"	"	"	"	"	"	"	"	"	"
"	"	"	"	"	"	"	"	"	"	"	"
"	"	"	"	"	"	"	"	"	"	"	"
"	"	"	"	"	"	"	"	"	"	"	"
"	"	"	"	"	"	"	"	"	"	"	"
984	17,200	0	1	CONC.	0	WOOD	CORR. ASBESTOS	WOOD	CORR. ASBESTOS	CORR. ASBESTOS	CONC.
"	"	"	"	"	"	"	"	"	"	"	"
"	"	"	"	"	0	CONC. WALLS	CONC.	0	0	0	STONE
"	"	"	"	CONC.	"	V.C. & G.I. PIPE	"	"	"	"	"
"	"	"	"	"	"	STEEL & G.I.	"	"	"	"	"

~~SECRET~~

PROJECT - 7209

TAB

BLDG. NO.	NAME	DATE STARTED	DATE COMPLETED	COST	GENERAL DIMENSIONS
9201-1	MAIN PROCESS BUILDING	3-1-43	12-13-43	29081.00	274' x 447'-6"
9201-2	" " "	3-25-43	3-25-44	26554.50	"
9201-3	" " "	4-15-43	8-15-44	193106.00	287'-4" x 243'-1"
9202	CHEMISTRY BUILDING "A"	4-7-43	10-31-43	4432.50	160' x 181'
9202-Ext	" " " " A' EXT.	4-26-44	2-10-45		65'-5" x 181'-8"
9203	CHEMISTRY BUILDING "B"	4-7-43	3-9-44	758.40	105' x 159'
9204	No. 2 PROCESS BUILDING	5-15-43	8-15-44	157014.00	241' x 368'-8"
9205	ANALYSIS LABORATORY	6-9-43	4-7-44	854.00	30' x 60'
9401	BOILER HOUSE	3-9-43	2-15-45	13863.00	79'-1" x 220'-5"
9404-1	WATER PUMP HOUSE (FOR 9201-1)	5-10-43	9-30-43	1251.00	25'-1" x 185'-14"
9404-2	" " " " "	6-1-43	10-30-43	1139.00	"
9404-3	" " " (FOR 9201-2)	7-1-43	12-15-43	1368.00	25'-4" x 221'-14"
9404-4	" " " " "	7-1-43	12-5-43	1232.00	"
9404-5	" " " (FOR 9201-3)	6-5-43	4-30-44	1466.00	25'-1" x 229'-0"
9404-6	" " " (FOR 9731)	5-10-43	9-15-43	142.00	20'-1" x 38'-7"
9404-7	" " " (FOR 1204)	7-25-43	11-8-43	642.00	25'-1" x 121'-14"
9404-8	" " " " "	7-25-43	12-9-43	585.00	"
9404-15	" " " (FOR 9202)	10-26-43	1-20-44	12.00	11' x 18'
9409-1	WATER COOLING TOWER (FOR 9201-1)	5-22-43	9-30-43	2906.00	33'-2" x 241'-8"
9409-2	" " " " "	5-22-43	10-30-43	2727.00	"
9409-3	" " " (FOR 9201-2)	6-1-43	11-20-43	2265.00	"
9409-4	" " " " "	6-1-43	11-27-43	2196.00	"
9409-5	" " " (FOR 9201-3)	6-3-43	5-6-44	2443.00	"
9409-6	" " " (FOR 9731)	5-20-43	7-31-43	582.00	33'-4" x 52'-9"
9409-7	" " " (FOR 9204)	7-15-43	11-30-43	1105.00	27'-2" x 82'-9"
9409-8	" " " " "	7-15-43	12-5-43	1021.00	"
9409-18	" " " (FOR 9202)	8-21-44	10-18-44	392.00	27' x 39'-6"
9415	DISTILLED WATER PLANT	8-7-43	4-30-44	2050.00	1-20' DIA. 1-18' DIA.
9416-1	TREATING HOS. FOR COOL. TWR. (FOR 9409-1&2)	7-21-43	10-25-43		13'-4" x 18'-8"
9416-2	" " " (FOR 9409-3&4)	9-8-43	10-30-43		"
9416-3	" " " (FOR 9409-5)	8-5-43	12-15-43	404.00	"
9416-4	" " " (FOR 9409-6)	7-21-43	10-20-43		13'-3" x 17'-0"
9416-5	" " " (FOR 9409-7&8)	8-5-43	10-30-43		13'-4" x 18'-8"
9418-1	CLEAN OIL TANK BLDG. (FOR B-300)	9-6-43	10-15-43		18' x 22'
9418-2	" " " (FOR B-301)	"	"		"
9418-3	" " " (FOR 303)	9-1-43	9-30-43		"
9418-4	" " " (FOR 304)	10-5-43	11-2-43	522.00	"
9418-5	" " " (FOR 305)	10-5-43	11-8-43		"
9418-6	" " " (FOR 306)	10-5-43	12-10-43		"
9418-7	" " " (FOR 307)	11-16-43	2-29-44		"
9419	DIST. WATER & PREP. TREATMENT BLDG.	12-27-43	3-15-44	241.00	22'-5" x 48'
9420	" " " " "	1-10-44	3-31-44		"
9421	" " " " "	8-22-43	4-30-44	5284.00	40' x 26'
9422	" " " " "	6-23-43	1-31-44	3258.00	22, 178 LF.
9423	" " " " "	7-4-43	12-20-43	666.60	55, 021 LF.

FLOOR AREA (SQ. FT.)	CUBE (CU. FT.)	BASEMENT	NR FLOORS	FOOTINGS	FOUNDATION PIERS	TYPE FRAME	EXT. WALLS	INT. WALLS	ROOF DECK	ROOFING	FLOOR
396	7341	TANK	0	CONC.	0	CONC.	CONC. & ACID BRICK	CONC.	WOOD	4 PLY-BUILT-UP	CONC & BRICK
270	4862	"	0	"	0	" CONC. WOOD & CORR. METAL	CONC.	0	"	5 PLY-BUILT-UP	CONC.
184 EA	2024 EA	0	1	CONC.	CONC. & Wood	WOOD	NOV. SIDING	0	WOOD	ROLL ROOF	WOOD
120	1,669	0	1	CONC.	0	BRICK	BRICK	0	CONC.	TAR & GRAVEL	CONC.
2000	40,186	0	1	"	CONC.	CONC.	"	BRICK	"	"	"
1,192	35,000	1	1	"	0	WOOD	NOV. SIDING	0	WOOD	ASPH. SHINGLE	"
448	6380	0	1	"	0	"	"	0	"	"	"
1,345	19,453	0	1	"	0	"	CORR. ASBESTOS	TRANSITE	CORR. ASBESTOS	CORR. ASBESTOS	"
46,694	555,372	0	1	CONC.	CONC.	WOOD	NOV. SIDING	WOOD	WOOD	TAR & GRAVEL	CONC.
13,147	184,787	0	1	"	"	"	"	"	"	"	"
750	13,200	0	1	"	"	CONC. BLOCK	CONC. BLOCK	0	"	ASPH. SHINGLE	WOOD
49	582	0	1	"	0	WOOD	NOV. SIDING	0	"	ROLL ROOF	"
"	"	"	"	"	"	"	"	"	"	"	"
"	"	"	"	"	"	"	"	"	"	"	"
"	"	"	"	"	"	"	"	"	"	"	"
8658	139,450	0	1	0	0	"	"	WOOD	"	ASPH. SHINGLE	CONC.
41,000	563,000	0	2	CONC.	CONC.	"	"	"	"	"	WOOD
18,600	316,000	0	1	"	0	"	"	"	"	ROLL ROOF	CONC.
6,563	119,437	0	1	"	CONC.	STRUCT. TILE	STRUCT. TILE	"	"	ASPH. SHINGLE	"
18,302	338,527	1	1	"	"	"	"	WOOD, TILE & CONC.	"	"	"
53,172	1,067,715	0	1	"	"	WOOD	NOV. SIDING	WOOD	"	5 PLY-BUILT-UP	"
3516	65,471	0	1	"	0	"	"	"	"	ASPH. SHINGLE	"
26,958	531,642	1	1	"	CONC.	"	"	"	"	& ROLL ROOF	"
1906	33,233	0	1	"	"	"	"	"	"	ASPH. SHINGLE	"
"	"	"	"	"	"	"	"	"	"	"	"
"	"	"	"	"	"	"	"	"	"	"	"
26,526	492,870	"	1	"	"	"	"	"	"	5 PLY-BUILT-UP	"
"	"	"	1	"	"	STEEL & WOOD	-	-	-	-	WOOD
42,593	653,720	0	1	CONC.	CONC.	WOOD	NOV. SIDING	WOOD	WOOD	5 PLY-BUILT-UP	CONC.
45,804	752,400	0	1	"	"	"	"	"	"	"	"
948	10,220	0	1	"	0	"	"	"	"	"	CONC. & GRAVEL
816	9,245	0	1	"	CONC.	"	"	"	"	"	"
406	4,263	0	1	0	0	"	"	"	"	"	CONC.
11,720	207,087	0	1	CONC.	CONC.	"	"	"	"	"	"
3,541	56,435	0	1	"	"	"	"	"	"	ASPH. SHINGLE	"
15,364	77,000	0	1	"	"	"	"	"	"	"	"

STONE

PROJECT - 7209

BLDG. No	NAME	DATE STARTED	DATE COMPLETED	COST	GENERAL DIMENSION
9502-5-1	OUTSIDE STEAM & PROCESS LINES	6-10-43	2-29-44	704600	
9510-A	PROCESS WASTE DISPOSAL	9-1-43	4-30-44		19'x25'
9510-B	" " "	"	"		17'x20'
9507	DRAINAGE	5-1-43	5-31-44	411400	14265 L. (EACH)
9603-1	FENCE & GUARD TOWERS (12 GUARD TOWERS ONLY)	4-10-43	8-31-43		13-6'x13'
9605	AUTO, TRUCKS & TRACTOR			17800	
9609	OIL PUMP HOUSE & UNLOAD. STATION	9-15-43	10-25-43	8400	14'6"x13'6"
9610	OIL STORAGE HOUSE	6-10-43	8-3-43	39500	42'x52'
9611	SEWAGE EJECTOR STATION	5-10-43	7-20-43		17'x18'
9616	CAUSTIC UNLOADING STATION	6-25-43	8-28-43	6000	14'8"x32'
9620-2	OIL PURIFICATION & PUMP HOUSE	6-22-44	8-18-44	123900	21'x68'2"
9512	ELECTRIC DISTRIBUTION	5-15-43	5-22-44	288300	45,760 L.
9701-1	EXAMINATION BUILDING (INCL. ADDITION)	6-25-43	10-15-44	316900	385'x432'
9701-2	" " "	9-21-43	11-24-43	15100	365'x49'
9702	TELEPHONE BUILDING (INCL. ADDITION)	10-14-43	3-31-44		2340'x34'
9703-1	GATE HOUSE	10-13-43	11-18-43	5000	6'x10'
9703-2	" " "	"	"		"
9703-4	" " "	12-8-43	1-19-44		"
9703-5	" " "	"	"		"
9704	ADMINISTRATION BUILDING	3-17-43	8-15-43	421000	40'x218'
9704-2	" " "	11-25-43	12-31-43		127'x229'
9705	GUARD HEADQUARTERS	6-25-43	12-31-43	163900	148'6"x309'
9706	MEDICAL SERVICE BUILDING	6-7-43	2-16-44	371900	48'x148'
9706-2	" " "	3-24-44	8-15-44		133'x25'
9709	SHOP	5-1-43	10-13-43	869700	154'x300'
9710	FIRE HEADQUARTERS	5-21-43	7-8-43	50800	59'x61'6"
9711-1	CAFETERIA (GENERAL)	4-7-43	6-30-44	459500	200'8"x210'
9711-2	" (FOR 9201-1&2)	6-10-43	12-31-43		37'x53'
9711-3	" (FOR 9201-2&3)	6-14-43	12-31-43		"
9711-4	"	8-20-43	12-31-43		"
9712	GARAGE & REPAIR SHOP	12-18-43	2-29-44	156400	110'6"x25'
9713	HIGHWAY CROSSOVER	4-24-44	5-6-44	3600	80'7'x9'
9720-1	WAREHOUSE & RECEIVING OFFICE	5-8-43	7-31-43	413900	192'x224'
9720-2	" " "	5-5-43	8-31-43		152'x304'
9722	CLOCK ALLEY	12-10-43	1-31-44		41'6"x34'
9722-2	(CLOSED)	6-7-44	6-30-44	13600	17'x48'
9722-3	"	7-12-44	7-22-44		28'x30'
9722-1	CHANGE HOUSE & LOCKER RM. (FOR 9201-1&2)	6-5-43	9-30-43		106'x157'
9722-2	"	6-18-43	9-5-43	1336500	48'x90'
9722-3	"	6-17-43	9-30-43		110'x166'
9601	ROADWAY	4-10-43	3-31-44	109400	4.1 MILE
9602	ROADWAY	5-15-43	3-31-44	487000	4.04 "
9603	ROADWAY	3-1-43	5-15-44	332300	



FLOOR AREA (SQ. FT.)	CUBE (CU. FT.)	BASEMENT	NO. FLOORS	FOOTINGS	FOUNDATION PIERS	TYPE FRAME	EXT. WALLS	INT. WALLS	ROOF DECK	ROOFING	FLOOR
11,720	207,087	0	1	CONC.	CONC.	WOOD	NOV. SIDING	WOOD	WOOD	SPLY-BUILT-UP	CONC.
3,541	54,435	0	1	"	"	"	"	"	"	ASPH. SHINGLE	"
15,364	77,000	0	1	"	"	"	"	"	"	"	"
537	8388	0	1	"	"	"	"	"	"	"	"
5,734	101,293	0	1	"	"	"	"	"	"	"	"
2,482	39,478	0	1	"	0	"	"	"	"	"	"
11,720	207,087	0	1	CONC.	CONC.	WOOD	NOV. SIDING	WOOD	WOOD	SPLY-BUILT-UP	CONC.
12,294	162,833	0	1	"	"	"	"	"	"	TAR & GRAVEL	"
12,134	155,107	0	1	CONC.	CONC.	WOOD	NOV. SIDING	WOOD	WOOD	ROLL ROOF.	CONC.
782	10,485	0	1	CONC.	0	STRUCT. TILE	STRUCT. TILE	0	WOOD	ASPH. SHINGLE	CONC.
12,832	197,530	0	1	"	CONC.	WOOD	NOV. SIDING	WOOD	"	SPLY-BUILT-UP	"
3,645	68,926	0	1	"	"	STRUCT. TILE	STRUCT. TILE	0	"	ASPH. SHINGLE	"
35,960	93,5796	1	1	"	"	CONC.	BRICK	TILE & BRICK	CONC.	TAR & GRAVEL	"
851	15,602	0	1	"	"	BRICK	BRICK	0	"	"	"
"	"	"	"	"	"	"	"	"	"	"	"
"	"	"	"	"	"	"	"	"	"	"	"
"	"	"	"	"	"	"	"	"	"	"	"
10,574	254,874	0	1	"	0	STRUCT. TILE	STRUCT. TILE	STRUCT. TILE	WOOD	ASPH. SHINGLES & TAR & GRAVEL	"
10,574	268,341	0	1	"	0	"	"	"	"	ASPH. SHINGLE	"
10,763	255,069	0	1	"	0	"	"	"	"	"	"
5,374	107,600	0	1	"	CONC.	"	"	WOOD	"	SPLY-BUILT-UP	"
16,352	337,926	0	1	"	"	"	"	"	"	ASPH. SHINGLES	"
2,106	16,3071	0	1	"	"	"	"	"	"	SPLY-BUILT-UP	"
17,930	362,270	0	1	"	"	WOOD	NOV. SIDING	STRUCT. TILE	"	ASPH. SHINGLE	"
400	7,734	0	1	CONC.	CONC.	CONC.	CONC.	0	CONC.	TAR & GRAVEL	CONC.
228	3,105	0	1	"	0	STRUCT. TILE	STRUCT. TILE	0	WOOD	ASPH. SHINGLE	"
1,880	23,845	0	1	"	0	WOOD	NOV. SIDING	WOOD	"	"	"
2,000	21,000	0	1	"	WOOD	"	PLY-WOOD	0	"	ROLL ROOF.	WOOD
"	"	0	1	"	"	"	"	0	"	"	"
"	"	0	1	"	"	"	"	0	"	"	"
"	"	0	1	"	"	"	"	0	"	"	"
10,752	100,136	0	1	WOOD	"	"	"	0	"	"	"
720	7,560	0	1	CONC.	0	"	"	WOOD	"	"	CONC.
"	"	0	1	"	0	"	"	"	"	"	"
1,200	15,600	0	1	"	0	STRUCT. TILE	STRUCT. TILE	0	"	ASPH. SHINGLE	"
3,688	57,320	0	1	"	0	WOOD	NOV. SIDING	WOOD	"	"	"
2,700	39,150	0	1	"	0	"	"	"	"	"	"



PROJECT - 7209

BLDG. NO	NAME	DATE STARTED	DATE COMPLETE	GENERAL DIMENSION
9723-4	CHANGE HSE. LOCKER ROOM (FOR 9201-2(5))	6-28-43	10-14-43	10' x 17'
9723-5	" " " " " (" " " ")	6-26-43	9-30-43	10' x 17'
9723-6	" " " " " (" " " ")	6-9-43	9-30-43	10' x 17'
9723-7	" " " " " (" 9709)	6-28-43	7-31-43	10' x 17'
9723-8	" " " " " (" " ")	8-23-43	10-31-43	10' x 17'
9723-9	" " " " " (" 9202(9205))	6-5-43	7-31-43	10' x 17'
9723-10	" " " " " (" 9204)	8-20-43	11-25-43	10' x 17'
9723-11	" " " " " (" " ")	8-15-44	10-31-44	12.5' x 17'
9723-12	" " " " " (" " ")	See 7208		
9723-24	" " " " " (" 9202(9203))	1-25-45	4-15-45	10' x 17'
9727	LIQUID NITROGEN STORAGE	6-25-43	8-31-43	744' x 25' x 36'
9728	LAUNDRY	4-22-43	7-31-44	3075' x 23' x 23'
9729	DRY ICE STORAGE	6-9-43	8-31-43	60000' x 52' x 72'
9731	PILOT PLANT	4-13-43	11-15-43	3073' x 10' x 17'
9732-1	ACETONE STORAGE BLDG. (9201-1)	8-28-43	10-31-43	22' x 17'
9732-2	" " " (9201-2)	10-24-43	2-29-44	67' x 17'
9732-3	" " " (9201-3)	3-15-44	5-31-44	
9732-4	" " " (" ")	12-1-43	5-15-44	
9733	PROCESS DEVELOPMENT BLDG. (CHEMISTRY)	6-9-43	12-31-43	24800' x 52' x 210'
9734	" " " (ENGINEERING)	4-27-43	10-10-43	152100'
9735	" " " (PHYSICS)	4-27-43	11-30-43	118700'
9736	" " SHOP	7-15-43	2-29-44	167900' x 48' x 112'
9737	ELECTRICAL MAINTENANCE SHOP	7-2-43	2-15-44	215100' x 65' x 224'
9738	FOUNDRY	7-1-43	12-2-43	158700' x 50' x 160'
9739	PROCESS DEVELOPMENT BLDG. (ENGINEERING)	3-11-44	10-18-44	276' x 200' x 210'
7740	SOLVENT BUILDING	9-4-43	11-15-43	16500' x 22' x 22'
9741	GENERATOR BUILDING	9-9-43	11-30-43	12600' x 15' x 22'
9743	AMMONIA STORAGE BUILDING	10-1-43	10-15-44	12200' x 30' x 162'
9745-1	BARRACKS	4-5-44	4-23-44	20' x 100'
9745-2	"	"	"	83300'
9745-3	"	"	"	"
9745-4	"	"	"	"
9745-5	42 HUTS	8-9-44	8-30-44	16' x 16' EACH
9747-1	WASH HOUSE	4-13-44	4-23-44	16000' x 36' x 20'
9747-2	"	8-9-44	8-30-44	"
9752	REFRIGERATION BUILDING	3-3-44	3-31-44	23300' x 20' x 60'
9753	AUTOMOTIVE SERVICE OFFICE	12-10-43	1-31-44	38000' x 38' x 97'
9754	SERVICE STATION	12-10-43	1-31-44	82600' x 80' x 90'

CUBE	BASEMENT	NO FLOORS	FOOTINGS	FOUNDATION PIERS	TYPE FRAME	EXT WALLS	INT WALLS	ROOF DECK	ROOFING	FLOOR
145,900	0	1	CONC	CONC	WOOD	NOV. SIDING	WOOD & TILE	WOOD	BUILT UP ROOF	CONC.
13,100	0	1	CONC.	0	"	" "	0	"	ASPH SHINGLE	"
70,370	0	1	"	CONC.	"	" "	WOOD	"	" "	WOOD
75,192	0	1	"	"	"	" "	"	"	TAR & GRAVEL	CONC.
				Sub project						
L MAINTENANCE OFFICE				314						
MENT GARAGE				130						
HUTS				314						
				PE. 2207						
ORAGE HUT				2273						
HUT				2239						
STION STORAGE				331						
RECLAMATION OFFICE				331						
Y FIELD SHOPS				331						
AND FIELD SHOP				331						
OPS ANNEX				331						

PROJECT - 7209

BLDG. NO	NAME	DATE STARTED	DATE COMPLETED	COST	GENERAL DIMENSIONS
9755	GREASE RACK BUILDING	12-29-43	2-26-44	71000	80'x120'
9756	GAS CYLINDER STORAGE BLDG.	11-2-43	11-20-43	12800	25'x40'
9764	TRANSPORTATION & PAYMASTERS BLDG	2-18-44	3-25-44	45100	33'x134'
9766	PROCESS DEVELOPMENT LAB. (INCL. EXT.)	3-5-44	2-28-45	271200	75'x467'
	TEMPORARY BUILDINGS (see list below)			410900	
	TOTAL 4-12			11420000*	
		Sub-proj			
9901	SHEET METAL SHOP	119	260	9928	ELECT
9902	RIGGERS' LOFT	60	213	9929	HEAVY
9903	WELDING DEPARTMENT	420		9930	CANTEEN
9904	ADMINISTRATION ANNEX	159		9931	CHEM
9905	DIVISION "A" OFFICE	89	227	9932	"
9906	DIVISION "A" WAREHOUSE	103	177	9933	"
9907	ADMINISTRATION BUILDING	94		9934	JANIT
9908	CARPENTER SHOP	106		9935	CHEM
9909	MACHINE SHOP	119		9936	"
9910	WAREHOUSE	106		9937	"
9911	CEMENT WAREHOUSE	113		9938	WORK
9912	ELECTRIC WAREHOUSE	106			
9913	RIGGERS LOFT ANNEX	60-A		9940	SALVAGE
9914	RECEIVING WAREHOUSE	103			
9915	DIVISION "E" OFFICE	103		9942	TEMPOR
9916	DIVISION "E" QUARTERS	106		9943	STORAGE
9917	DIVISION "F" WAREHOUSE	103		9944	METAL
9918	DIVISION "D" WAREHOUSE	103			
9919	DIVISION "D" QUARTERS	106			
9920	DIVISION "E" WAREHOUSE	103			
9921	CANTEEN # 2	314			
9922	DIVISION "B" WAREHOUSE	89			
9923	DIVISION "F" HEADQUARTERS	89			
9924	PIPE SHOP	106	253		
9925	WAREHOUSE	106			
9926	VALVE PICKLING	141	149		
9927	PLATFORM	156			

FLOOR AREA SQ. FT.	CUBE CU. FT.	BASEMENT	NO. FLOORS	FOOTINGS	FOUNDATION PIERS	TYPE FRAME	EXT WALLS	INT. WALLS	ROOF DECK	ROOFING	FLOOR
5250	10,185,320	0	3	CONC.	CONC.	STRUCT. STEEL	ASBESTOS	TILE	PRE-CAST CONC.	TAR & GRAVEL	CONC.
4734	4,523,347	0	2	CONC.	CONC.	CONC.	CONC. & TILE	TILE	STRUCT. STEEL & CONC. PRE-CAST CONC.	TAR & GRAVEL	CONC.
17,240	5,868,445	1	2	CONC.	CONC.	STRUCT. STEEL	TILE	TILE	PRE-CAST CONC.	TAR & GRAVEL	CONC.
5800	1,191,465	0	2	CONC.	CONC.	STRUCT. STEEL	TILE	TILE	PRE-CAST CONC.	TAR & GRAVEL	CONC.
7343	3,194,166	0	6	CONC.	CONC.	STRUCT. STEEL	TILE	TILE	CONC. PRE-CAST CONC.	TAR & GRAVEL	CONC.
2459	2,099,915	0	1	CONC.	CONC.	STRUCT. STEEL	TILE	0	CONC. PRE-CAST CONC.	TAR & GRAVEL	CONC.
4321	1,232,366	0	3	CONC.	CONC.	STRUCT. STEEL & CONC.	TILE	TILE & STEEL	CONC.	TAR & GRAVEL	CONC. & STEEL
16,900	3,399,955	0	4	CONC.	CONC.	STRUCT. STEEL	TILE	TILE	CONC.	TAR & GRAVEL	CONC.
10,650	4,275,560	0	2	CONC.	CONC.	WOOD & STEEL	ASBESTOS, WOOD, TILE & ASBESTOS	TILE & WOOD	PRE-CAST CONC.	ASBESTOS & BUILT-UP, ASBESTOS & 4-PLY CONP.	CONC. & WOOD
2951	57,555	0	1	CONC.	0	WOOD & TILE	ASBESTOS	TILE	WOOD & CONC.	"	CONC.
826	15,755	0	1	CONC.	0	WOOD WALLS-TILE	TILE	0	WOOD	ASP. SHINGLE	CONC.
"	"	"	"	"	"	"	"	"	"	"	"
"	"	"	"	"	"	"	"	"	"	"	"
"	"	"	"	"	"	"	"	"	"	"	"
2400	0	0	TANK ONLY	CONC.	CONC.	0	CONC.	0	0	0	CONC.
"	"	"	"	"	"	"	"	"	"	"	"
7000	0	0	TANK ONLY	CONC.	CONC.	0	CONC.	0	0	0	CONC.
"	"	"	"	"	"	"	"	"	"	"	"
"	"	"	"	"	"	"	"	"	"	"	"
1300	0	0	TANK ONLY	CONC.	CONC.	0	CONC.	0	0	0	CONC.
"	"	"	"	"	"	"	"	"	"	"	"
1290	0	0	TANK ONLY	CONC.	CONC.	0	CONC.	0	0	0	CONC.
3700	0	0	TANK ONLY	CONC.	0	0	CONC.	0	0	0	CONC.
253	3,227	0	1	CONC.	0	WOOD	ASBESTOS	0	0	ASBESTOS	CONC.
"	"	"	"	"	"	"	"	"	"	"	"
"	"	"	"	"	"	"	"	"	"	"	"
396	4356	0	1	CONC.	0	WOOD	MOV. SLING	0	WOOD	SHINGLE	CONC.
"	"	"	"	"	"	"	"	"	"	"	"
0	0	0	TANK TOWER	CONC.	CONC.	STRUCT. STEEL	0	0	0	0	STEEL
"	"	"	"	"	"	"	"	"	"	"	"
974	1,3604	0	1	CONC.	0	WOOD	ASBESTOS	0	0	ASBESTOS	CONC.
"	"	"	"	"	"	"	"	"	"	"	"
"	"	"	"	"	"	"	"	"	"	"	"
0	0	0	FOUNDATIONS	"	0	CONC.	CONC.	0	0	0	STONE
0	0	0	0	"	CONC.	STRUCT. S.C.I.	0	0	0	0	0
0	0	0	0	"	CONC.	STRUCT. S.C.I.	0	0	0	0	0

J.O.7208

532
302
165000
fig 1 x 40
34, 40

BLDG. NO	NAME	DATE	DATE	COST	GENERAL DIMENSIONS
		STARTED	COMPLETED		
9201-4	MAIN PROCESS BUILDING	11-2-43	8-15-44	440448.00	312'x543'
9201-5	" " "	1-20-44	10-31-44	425572.00	"
9204-2	NO.2 " "	10-20-43	10-31-44	163798.00	241'x369'
9204-3	" " "	5-22-44	12-30-44	158935.00	241'x369'
9206	NO.2 " CHEMISTRY BLDG.	3-1-44	12-31-44	428900.00	167'x242'
9207	NO.1 " " "	6-22-44	INCOMPLETE	120803.00	170'x285'
9208	CHEMICAL STORAGE BUILDING	7-15-44	3-31-45	610200.00	80'x154'
9210	VACUUM PROCESS "	10-10-44	INCOMPLETE	58486.00	146'x146'
9211	SPECIAL MATERIAL CONVERSION BLDG	12-7-44	INCOMPLETE	13944.00	100'x158'
9209	BETA SALVAGE Building	Cancelled		21200	
9612-2	Grading	10-21-43	9-15-44	476700	
9401-2	BOILER HOUSE	11-15-43	10-15-44	1236000	55'x190'
9404-9	WATER PUMP HOUSE (FOR 9204-2)	1-15-44	8-31-44	133300	25'x10'x129'
9404-10	" " " (" 9204-2)	"	"	104900	"
9404-11	WATER PUMP CONTROL HSE.(FOR 9201-4)	1-31-44	6-15-44	65000	22'8'x42'
9404-12	" " " " (" ")	3-15-44	7-15-44	59000	"
9404-13	" " " " (" 9201-5)	4-7-44	8-31-44	49000	"
9404-14	WATER PUMP CONTROL HSE(" 9201-5)	4-7-44	9-15-44	55400	"
9409-9	WATER COOLING TOWER (" 9204-2)	12-20-43	3-25-44	129000	27'2'x82'9"
9409-10	" " " (" ")	"	"	122200	"
9409-11	" (INCL.PUMPS) " (" 9201-4)	2-8-44	6-24-44	170000	30'x212'8"
9409-12	" " " (" ")	3-11-44	7-15-44	181900	"
9409-13	" " " (" 9201-5)	4-4-44	8-15-44	172600	"
9409-14	" " " (" ")	4-5-44	9-7-44	161000	"
9409-15	" " " (" 9204-3)	7-15-44	9-7-44	35400	33'4'x39'8"
9409-16	" " " (" 9204-3)	"	"	39800	"
9409-17	" " " (" 9767)	5-22-44	9-15-44	31400	33'x39'4"
9409-19	" " " (" 9207)	7-15-44	4-15-45	73000	27'x116'
9416-6	TREATING HSE, BY-PASS SHELTER(FOR 9409-9&10)	2-1-44	7-31-44	15500	12'6'x22'3"
9416-7	" " " " (" 9409-11&12)	3-8-44	7-15-44	15500	"
9416-8	" " " " (" 9409-13&14)	4-8-44	8-15-44	13700	"
9416-9	" " " " (" 9409-15&16)	9-1-44	10-31-44	4500	"
9418-8	CLEAN OIL TANK BLDG. (" B2-300)	10-17-44	11-4-44	1000	18'x22'
9418-9	" " " " (" B2-301)	10-17-44	11-4-44		"
9420-9	DIS. WATER P.HSE (INCL STORE DEAIR. FOR 9204-2)	3-1-44	10-31-44		14'x14' FDN.
9420-10	" " " (" " " " 9204-2)	"	"		"
9420-11	" " " (" " " " 9201-4)	"	"	531300	30'4'x35'8"
9420-12	" " " (" " " " 9201-4)	"	"		"
9420-13	" " " (" " " " 9201-5)	"	"		"
9420-14	" " " (" " " " 9201-5)	"	"		"
1501	SUPPLEMENTS (4)	2-7-44	10-31-44	658800	28'x71'-5"
1502-113	OUTSIDE PIPES AND CO.	4-13-44	6-30-44	405900	
1503	OUTSIDE PIPES	11-10-43	5-21-44	563600	41,008 L.F.

J.O.7208

532
303
165002
P411000
P411000

BLDG. NO	NAME	DATE STARTED	DATE COMPLETED	COST	GENERAL DIMENSIONS
9201-4	MAIN PROCESS BUILDING	11-2-43	8-15-44	440448.00	312x543
9201-5	" " "	1-20-44	10-31-44	425572.00	"
9204-2	NO.2 " "	10-20-43	10-31-44	163798.00	241x369'
9204-3	" " "	5-22-44	12-30-44	158935.00	241x369'
9206	NO.2 " CHEMISTRY BLDG.	3-1-44	12-31-44	428900.00	167'x262'
9207	NO.1 " " "	6-22-44	INCOMPLETE	120803.00	170'x283'
9208	CHEMICAL STORAGE BUILDING	7-15-44	3-31-45	6106.00	80'x154'
9210	VACUUM PROCESS "	10-10-44	INCOMPLETE	58486.00	146'x146'
9211	SPECIAL MATERIAL CONVERSION BLDG	12-7-44	INCOMPLETE	13944.00	100'x158'
9209	BETA SALVAGE Building	cancelled		21200	
9612-2	Grading	10-21-43	9-15-44	476700	
9401-2	BOILER HOUSE	11-15-43	10-15-44	1236000	85'x190'
9404-9	WATER PUMP HOUSE (FOR 9204-2)	1-15-44	8-31-44	133300	25-10'x129'
9404-10	" " " (" 9204-2)	"	"	104900	"
9404-11	WATER PUMP CONTROL HSE.(FOR 9201-4)	1-31-44	6-15-44	65000	22-8'x42'
9404-12	" " " (" " ")	3-15-44	7-15-44	59600	"
9404-13	" " " (" 9201-5)	4-7-44	8-31-44	49000	"
9404-14	WATER PUMP CONTROL HSE(" 9201-5)	4-7-44	9-15-44	55400	"
9409-9	WATER COOLING TOWER (" 9204-2)	12-20-43	3-25-44	129000	27-2'x82-9'
9409-10	" " " (" " ")	"	"	122200	"
9409-11	" (INCL.PUMPS) (" 9201-4)	2-8-44	6-24-44	170000	30'x212-8'
9409-12	" " " (" " ")	3-11-44	7-15-44	181900	"
9409-13	" " " (" 9201-5)	4-4-44	8-15-44	172600	"
9409-14	" " " (" " ")	4-5-44	9-7-44	161000	"
9409-15	" " " (" 9204-3)	7-15-44	9-7-44	35400	33-4'x39-8'
9409-16	" " " (" 9204-3)	"	"	39800	"
9409-17	" " " (" 9207)	5-22-44	9-15-44	31400	33'x39-4"
9409-19	" " " (" 9207)	7-15-44	4-15-45	73000	27'x116'
9416-6	TREATING HSE, BY-PASS SHELTER(FOR 9409-9&10)	2-1-44	7-31-44	15500	12-6'x22-3'
9416-7	" " " " (" 9409-11&12)	3-8-44	7-15-44	15500	"
9416-8	" " " " (" 9409-13&14)	4-8-44	8-15-44	13700	"
9416-9	" " " " (" 9409-15&16)	9-1-44	10-31-44	4500	"
9418-8	CLEAN OIL TANK BLDG. (" B2-300)	10-17-44	11-4-44	1000	18'x22'
9418-9	" " " " (" B2-301)	10-17-44	11-4-44		"
9420-9	DIS WATER PHSE (INCL STORE DEAIR. FOR 9204-2)	3-1-44	10-31-44		14'x14' FDN.
9420-10	" " " " (" " " " 9204-2)	"	"		"
9420-11	" " " " (" " " " 9201-4)	"	"	931300	36-4'x35-8'
9420-12	" " " " (" " " " 9201-4)	"	"		"
9420-13	" " " " (" " " " 9201-5)	"	"		"
9420-14	" " " " (" " " " 9201-5)	"	"		"
1301	SUPPLEMENTAL (4)	2-7-44	10-31-44	658500	28'x71-5"
1302	WINDSE PIPES AND ()	4-13-44	2-30-44	405900	
1303	WINDSE PIPES AND ()	11-10-43	5-31-44	563600	41,000 L.F.

AREA	CUBE	BASEMENT	NO FLOORS	FOOTINGS	FOUNDATION PIERS	TYPE FRAME	EXT WALLS	INT WALLS	ROOF DECK	ROOFING	FLOOR
				CONC.		PIPE V.C.C. CONC. AND 4" CONC. SLAB					
		0	1	CONC.	0	WOOD	NO SIDING	0	WOOD	ASPH SHINGLE	CONC
		0	1	"	CONC/WOOD	"	NO SIDING	0	"	ROLL ROOF	WOOD
		0	1	CONC	0	WOOD	CORR. ASS.	0	WOOD	CORR. ASS.	CONC.
		0	1	"	0	CONC	NO SIDING	CONC	CONC	ASPH SHINGLE	CONC
		0	1	"	CONC	STR. TILE	STR. TILE	WOOD	"	TAR/SHINGLE	"
		0	1	"	"	WOOD	NO SIDING	0	WOOD	ASPH SHINGLE	"
		0	1	"	0	"	CORR. ASS.	STR. TILE	"	CORR. ASS.	"
		0	1	"	CONC	STR. TILE	STR. TILE	0	CONC	WATER PROOF	"
		0	1	"	"	WOOD	NO SIDING	WOOD	WOOD	TAR/SHINGLE	"
		0	1	"	"	"	"	0	"	"	CONC/SHAD
		0	1	"	"	CONC	"	WOOD	"	ASPH SHINGLE	CONC
		0	2	"	"	WOOD	NO SIDING	"	"	TAR/SHINGLE	CONC
		0	2	"	"	WOOD	"	"	"	RULL UP	CONC
		0	1	"	"	BRICK	BRICK	"	"	TAR/SHINGLE	"
		0	1	"	"	WOOD	NO SIDING	STE. TILE	"	"	"
		0	1	"	"	WOOD	"	STE. TILE	"	"	"
		0	1	"	"	WOOD	"	WOOD	"	"	"
		0	1	"	"	WOOD	"	"	"	"	"
		0	1	"	"	"	"	"	"	"	"
		0	1	"	"	"	"	"	"	"	"
		0	1	"	"	"	"	"	"	"	"
		0	2	"	"	"	"	WOOD	"	"	CONC/SHAD
		0	2	"	"	"	"	"	"	"	"
		0	1	"	"	"	"	"	"	ASPH SHINGLE	CONC
		0	1	"	"	"	"	"	"	"	"
		0	2	"	"	STEEL/CONC & WOOD	CONC/WOOD	"	"	"	CONC/SHAD
		0	1	"	"	0	STR. TILE	STR. TILE	"	ASPH SHINGLE & ROLL ROOF	CONC
		0	1	"	CONC	"	"	"	"	"	"
		0	1	"	"	"	"	"	"	ASPH SHINGLE	"
		0	1	"	"	WOOD	NO SIDING	0	"	TAR/SHINGLE	"
		0	1	"	"	STEEL/STR. TILE	STR. TILE	STR. TILE	"	"	"
		0	1	"	0	STR. TILE	"	"	"	"	"
		0	2	"	CONC	STEEL/STR. TILE	"	"	CONC	"	"
		TANK	1	"	0	STR. TILE	STR. TILE	0	WOOD	ASPH SHINGLE	"
		"	1	"	"	"	"	"	"	"	"
		"	1	"	"	"	"	"	"	"	"
		"	1	"	"	"	"	"	"	"	"

J.O. 7208

	NAME	DATE STARTED	DATE COMPLETED	COST	GENERAL DIMENSIONS
9605	AUTO, TRUCKS & TRACTORS			2200	
9584	SEWER LINES & DISPOSAL	11-11-43	5-31-44	322,600	33,059 L.F.
9507	DRAINAGE.	11-1-43	8-15-44	348,500	27,812 L.F.
9512-2	ELECTRIC DISTRIBUTION AND TELEPHONE	3-1-44	5-31-45	201,100	26,620 L.F.
9510-2	PROCESS WASTE DISPOSAL (BLDG. 9206 & 9744)	7-15-44	10-10-44	47,300	16x48
9510-4	" " " (" 9211)				
9603-2	FENCE & GUARD TOWERS (GUARD TOWERS ONLY)	4-18-44	4-22-44	(incl 9587)	15.6x13.6
9601	RAILROADS	10-21-43	7-15-44	100,000	2.7 MILES
9609-2	OIL PUMP HSE. & UNLOADING STATION	3-22-44	7-31-44	43,000	10.8x18.8
9611-2	SEWAGE EJECTOR STATION	4-20-44	6-23-44	(incl 9584)	28x34
9616-2	CHEMICAL PUMPING STATION	9-26-44	4-30-45	455,500	22.8x93.4
9616-3	CHEMICAL UNLOADING STA. (FOR 9207)	10-3-44	3-15-45		2.18x7.10
9620-1	OIL PURIFICATION & PUMP HSE. (GENERAL)	4-10-44	7-31-44	51,700	24.4x68.7
9621	HYDROLYSIS TOWER & PUMP HOUSE	8-9-44	5-7-45	178,900	32x50
9602	ROADS	11-10-43	6-30-45	321,400	4.08 Miles
9701-3	EXAMINATION BUILDING	12-11-44	3-31-45	126,200	288x346
9703-10	GATE HOUSE	1-1-45	3-31-45	65,000	10x120
9710-2	FIRE HEADQUARTERS	1-9-44	5-30-44	57,800	68x73
9711-5	CAFETERIA (FOR WHOLE AREA)	3-15-44	8-31-44	862,500	129x224
9711-6	" (FOR BLDG. 9201-465)	1-18-45	INCOMPLETE		116x138.6
9720-5	WAREHOUSE & RECEIVING CLERKS OFFICE	5-27-44	6-30-44	302,000	304x172
9723-12	CHANGE HOUSE & LOCKER ROOM (FOR 9206)	7-15-44	10-30-44		166.7x110
9723-14	" " " " " (" 9204-2)	6-15-44	9-7-44		95.6x146
9723-15	" " " " " (" ")	6-7-44	8-31-44		114.6x234
9723-16	" " " " " (" 9201-4)	5-15-44	7-15-44	126,900	114.6x234
9723-18	" " " " " (" ")	"	"		122 x 234.4
9723-19	" " " " " (" 9201-5)	5-27-44	8-16-44		114.6x234
9723-21	" " " " " (" ")	5-27-44	8-11-44		122x234.4
9723-22	" " " " " (" 9207)	9-1-44	INCOMPLETE		75x144
9723-23	" " " " " (" 9207)	12-21-44	4-15-45		75x96
9733-2	PROCESS DEVELOPMENT BLDG (CHEMISTRY)	8-17-44	10-15-44		51x210.4
9733-3	" " " " " (" ")	8-17-44	10-30-44	833,800	51x210.4
9733-4	" " " " " (" ")	10-13-44	4-15-45		54x210
9743-2	AMMONIA STORAGE BUILDING	11-8-44	3-15-45	532,000	61.4x83
9744	ELECTROPLATING BUILDING	4-15-44	2-28-45	309,800	50x144
9767	COMPRESSOR BUILDING (FOR 9206)	5-21-44	10-31-44		48x77
9767-2	" " " " (" ")	8-10-44	10-31-44	276,300	20.8x35.8
9767-3	" " " " (" 9207)	10-13-44	2-28-45		28x58
9768	FAN HOUSE (" 9206)	7-22-44	10-31-44	93,500	32.2x38.11
9769	INCINERATOR (" 9207)	8-7-44	INCOMPLETE	357,000	58x98
9770-1	SAMPLING TANK HOUSE (" 9207)	2-14-45	"		9.5x16.5
9770-2	" " " " (" ")	"	"		"
9770-3	" " " " (" 9769)	"	"	8,000	"
9770-4	" " " " (" 9210)	"	"		"
9770-5	" " " " (" 9211)	"	"		"
TOTAL				15,500,000	

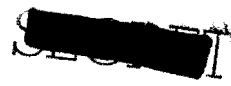

No. Floors	Footings	Foundation Piers	Type Frame	Ext. Walls	Int. Walls	Roof Deck	Roofing	Floor
head house 2	Concrete	Concrete	Str. Steel	Tile	Tile.	light weight Concrete	Tar and Gravel	Concrete
Wings 1 Tank only	Concrete	0	0	Concrete	0	0	0	Concrete
1	Concrete	Concrete	Wood	Nov. Siding	Wood.	Wood	Built up.	Concrete
1	Concrete	Concrete	Str. Steel	Corr. Asbestos	Wood.	Asbestos protected 2" Gyp. Plank	Corr. Metal Built up	Concrete
2	Concrete	Concrete	Str. Steel	Tile	Tile	Precast Conc.	Tar & Gravel	Concrete
Tank only	Concrete	Concrete	0	Concrete	0	0	0	Concrete
Tank only	Concrete	Concrete	0	Concrete	0	0	0	Concrete
1	Concrete	0	Wood	Asbestos	0	0	Corr. Asbestos	Concrete



Station	Floor Area (sq ft)	Cube (cu ft)	Basement	No. Floors	Footings	Foundation	Notes
1010	127,850	2,172,417	0	Head house	Concrete	Concrete	St
1011	2337	0	0	Walls	Concrete	Concrete	
1012	24,850	0	0	Concrete	Concrete	Concrete	
1013	1,114	19,521	0	Concrete	Concrete	Concrete	
1014			0	Concrete	Concrete	Concrete	
1015			0	Concrete	Concrete	Concrete	
1016			0	Concrete	Concrete	Concrete	
1017			0	Concrete	Concrete	Concrete	
1018			0	Concrete	Concrete	Concrete	
1019			0	Concrete	Concrete	Concrete	
1020			0	Concrete	Concrete	Concrete	
1021			0	Concrete	Concrete	Concrete	
1022			0	Concrete	Concrete	Concrete	
1023			0	Concrete	Concrete	Concrete	
1024			0	Concrete	Concrete	Concrete	
1025			0	Concrete	Concrete	Concrete	
1026			0	Concrete	Concrete	Concrete	
1027			0	Concrete	Concrete	Concrete	
1028			0	Concrete	Concrete	Concrete	
1029			0	Concrete	Concrete	Concrete	
1030			0	Concrete	Concrete	Concrete	
1031			0	Concrete	Concrete	Concrete	
1032			0	Concrete	Concrete	Concrete	
1033			0	Concrete	Concrete	Concrete	
1034			0	Concrete	Concrete	Concrete	
1035			0	Concrete	Concrete	Concrete	
1036			0	Concrete	Concrete	Concrete	
1037			0	Concrete	Concrete	Concrete	
1038			0	Concrete	Concrete	Concrete	
1039			0	Concrete	Concrete	Concrete	
1040			0	Concrete	Concrete	Concrete	
1041			0	Concrete	Concrete	Concrete	
1042			0	Concrete	Concrete	Concrete	
1043			0	Concrete	Concrete	Concrete	
1044			0	Concrete	Concrete	Concrete	
1045			0	Concrete	Concrete	Concrete	
1046			0	Concrete	Concrete	Concrete	
1047			0	Concrete	Concrete	Concrete	
1048			0	Concrete	Concrete	Concrete	
1049			0	Concrete	Concrete	Concrete	
1050			0	Concrete	Concrete	Concrete	

Bldg No	Name	Date Started	Date Completed	Estimated Cost	General Dimensions
	Contract W-1A-108 Eng 49 J.O. 7538				
9212	Beta Chemistry	4-25-45	Incomplete	4,650,000	Head Ht 73'9" Awings 37'2"
9409-22	Water Cooling Tower	6-14-45	Incomplete	100,000	33'0" x
9723-25	Change House and Locker Room	6-5-45	Incomplete	180,000	104'-1"
9720-6	Warehouse	6-21-45	Incomplete	350,000	101'-10" Wing 74'
	Contract W1A-108 Eng.60 J.O. 7558				
9204-4	No. 2 Process Building	4-11-45	Incomplete	17,500,000	241'0" x
9409-20	Water Cooling Tower	5-23-45	Incomplete	112,300 (a)	33'4"
9409-21	Water Cooling Tower	5-23-45	Incomplete		33'4"
9416-10	Treating House & By Pass Shelter	5-23-45	Incomplete	(included in (a))	12'6" x

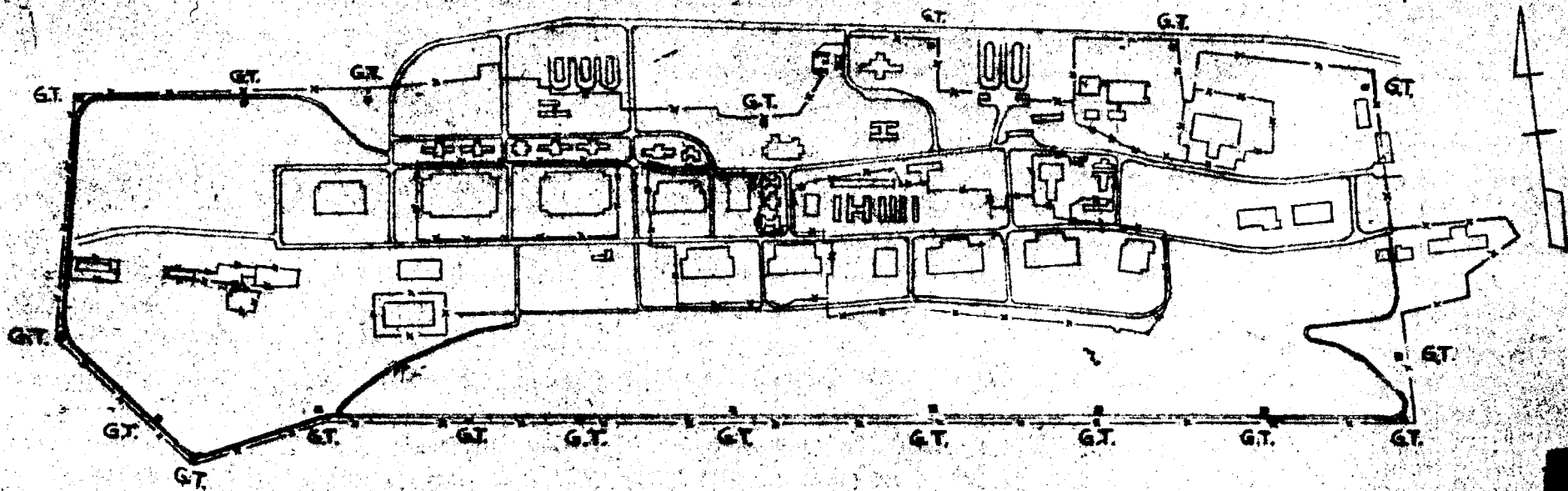

D-7

Y-12 AREA

Perimeter Fence 28,060' = 5.31 Miles
 Interior Fence 29,709' = 5.63 Miles
 Guard Towers 19

Note:

G.T. Means Guard Towers

Y-12 AREA
 CLINTON ENGINEER WORKS
 PERIMETER & INTERIOR FENCES,
 AND GUARD TOWERS.
 STONE & WEBSTER ENGINEERING CORPORATION
 FS 08484
 SCALE 1" = 1200'
 DATE 7-1-45
 J.O. No. 7558

SUBM. BY *W.C.* DATE
 APPR. BY *[Signature]* DATE
 Resident Engineer

D-9

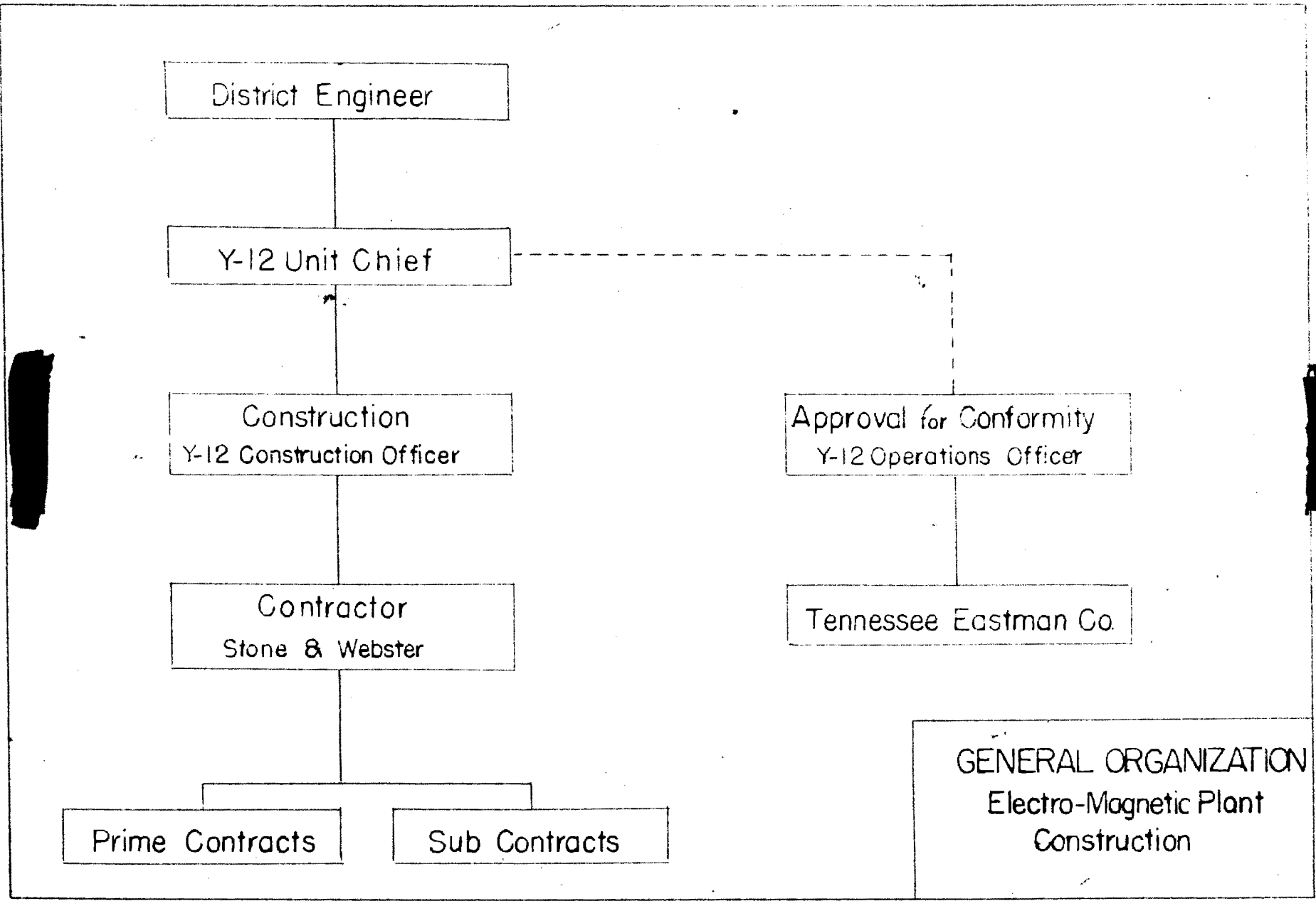

District Engineer

Y-12 Unit Chief

Construction
Y-12 Construction Officer

Contractor
Stone & Webster

Prime Contracts

Sub Contracts

Approval for Conformity
Y-12 Operations Officer

Tennessee Eastman Co.

GENERAL ORGANIZATION
Electro-Magnetic Plant
Construction

R WORKS



ENGR. CORP.

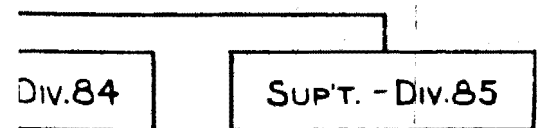
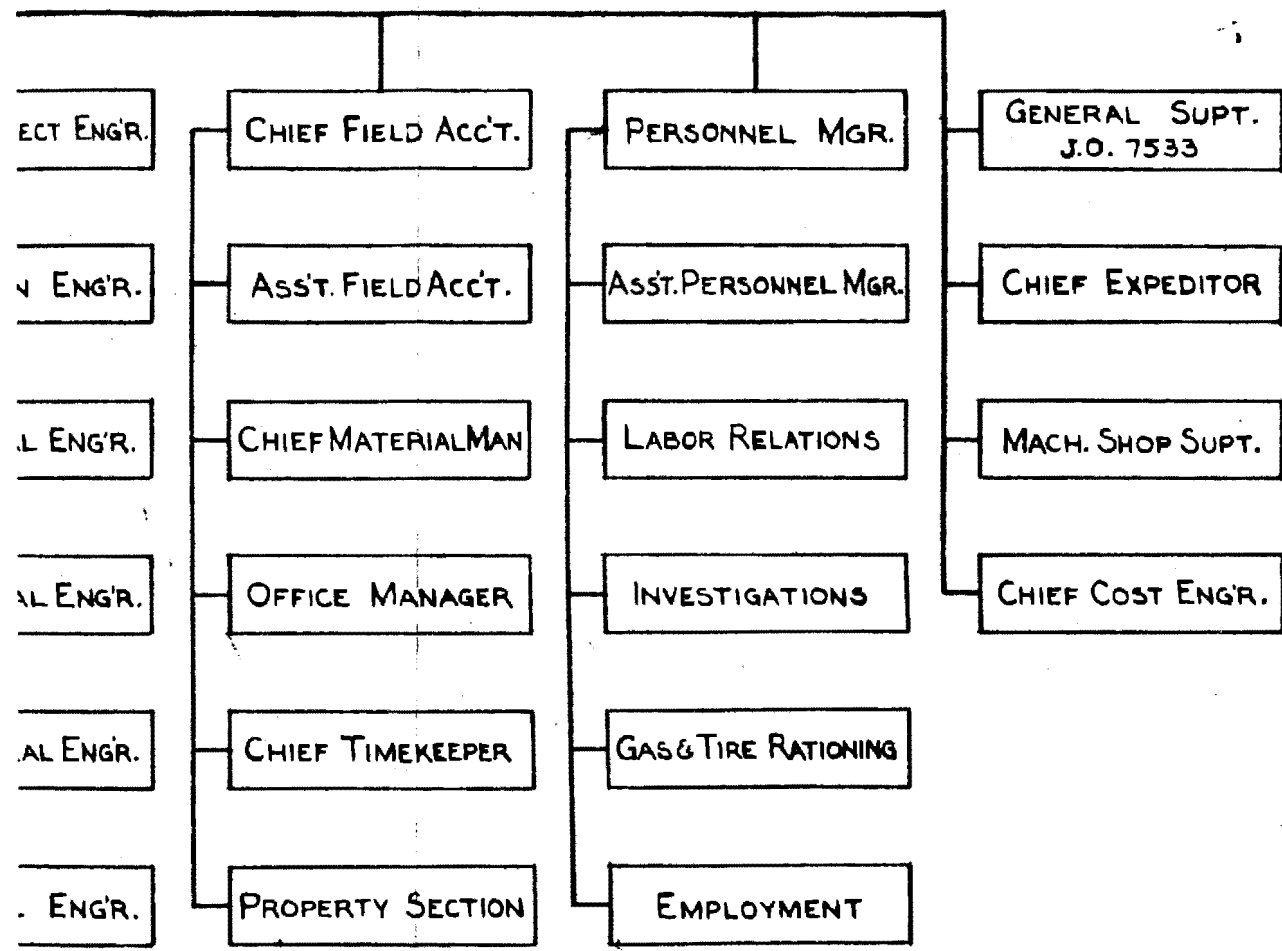
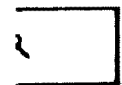

~~SECRET~~
CLINTON ENGINEER WORKS
STONE & WEBSTER ENGR. CORP.
"KEY ORGANIZATION CHART"
Y-12 AREAS D-10

CLINTON ENGINEER WORKS

STONE & WEBSTER ENG'R. CORP.
A-E-M

RESIDENT MANAGER

PROJECT MANAGER

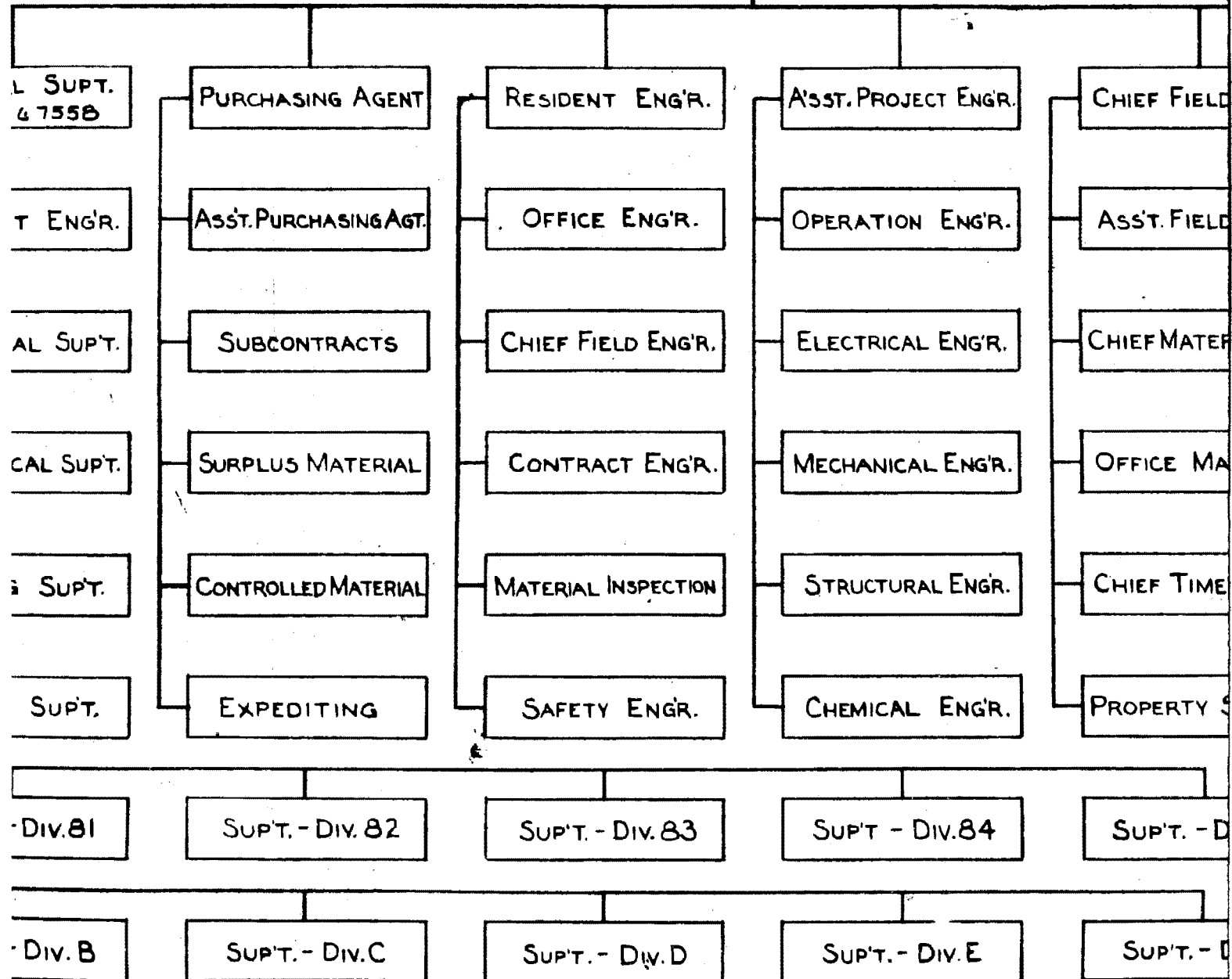

NO. OF EMPLOYEES ON PAYROLL (000 OMITTED)

D-11

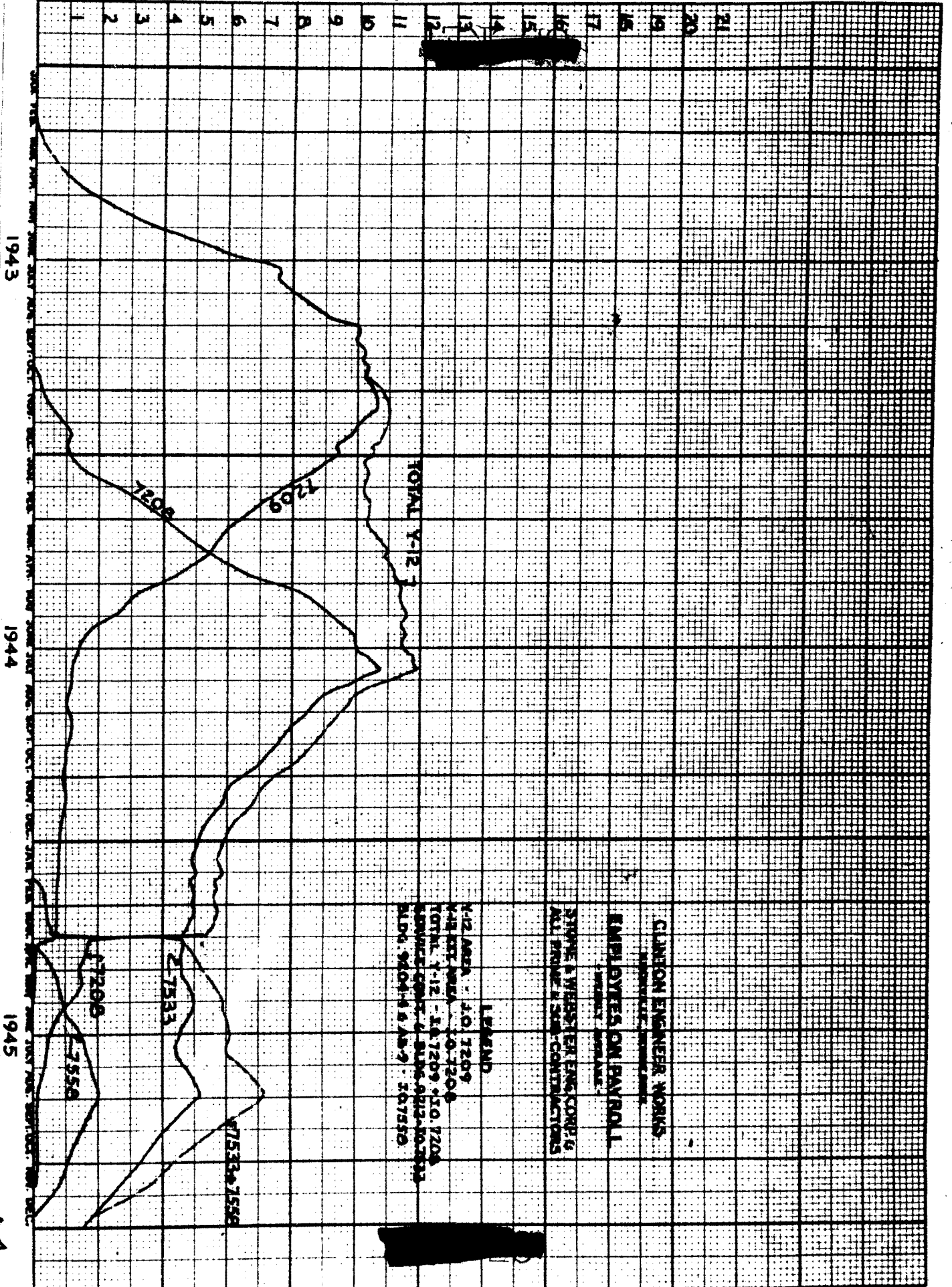

NO. 2 8 1/2 INCH

REPRODUCED BY U. S. A.

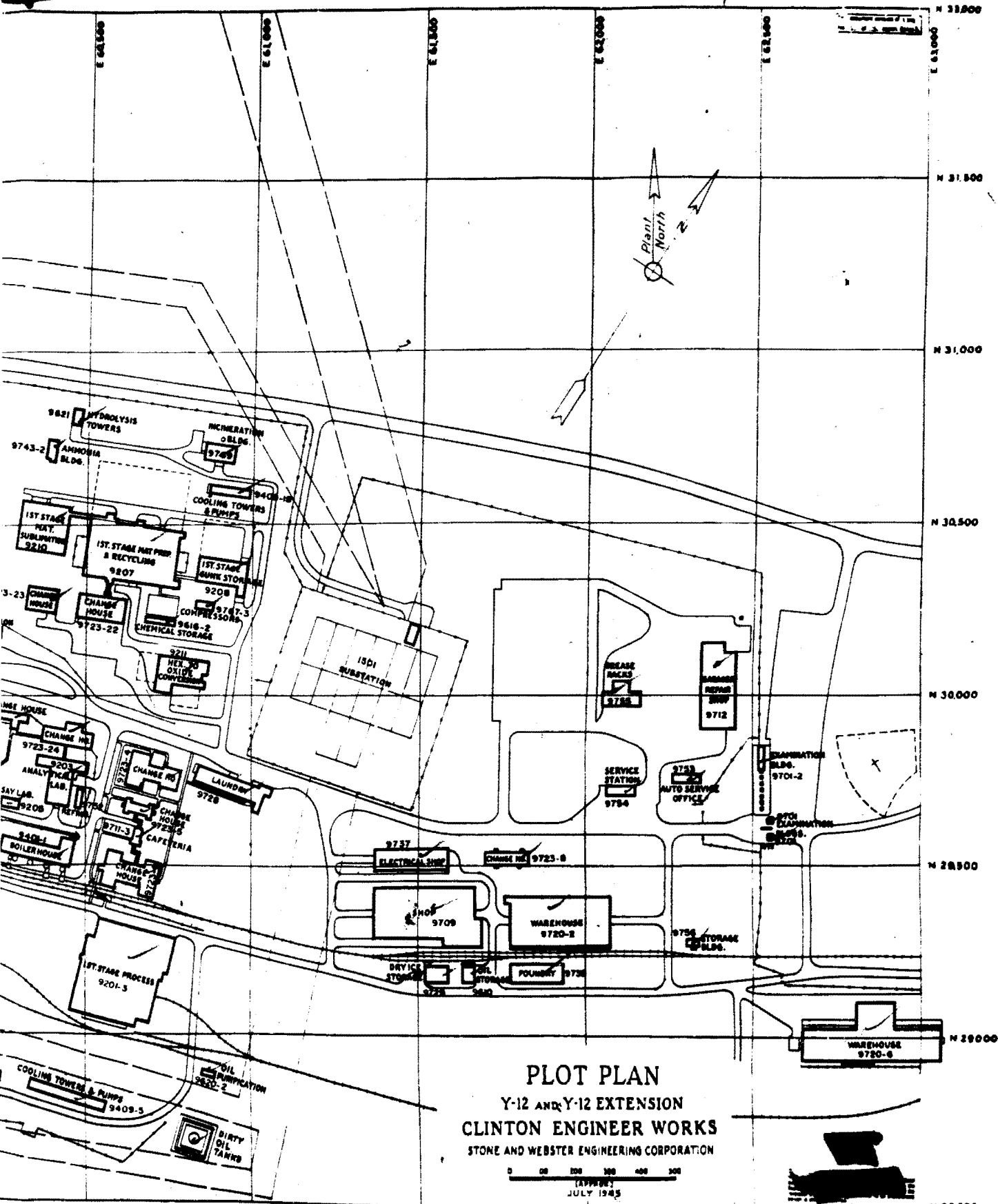

PLOT PLAN
 Y-12 AND Y-12 EXTENSION
 CLINTON ENGINEER WORKS
 STONE AND WEBSTER ENGINEERING CORPORATION

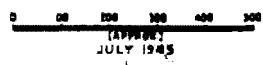

JULY 1945

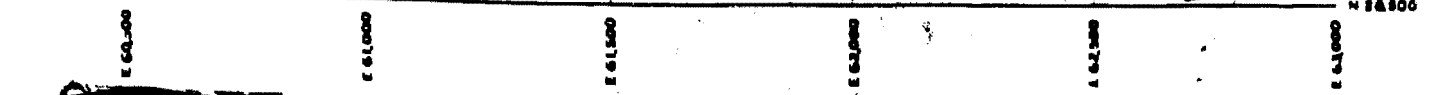

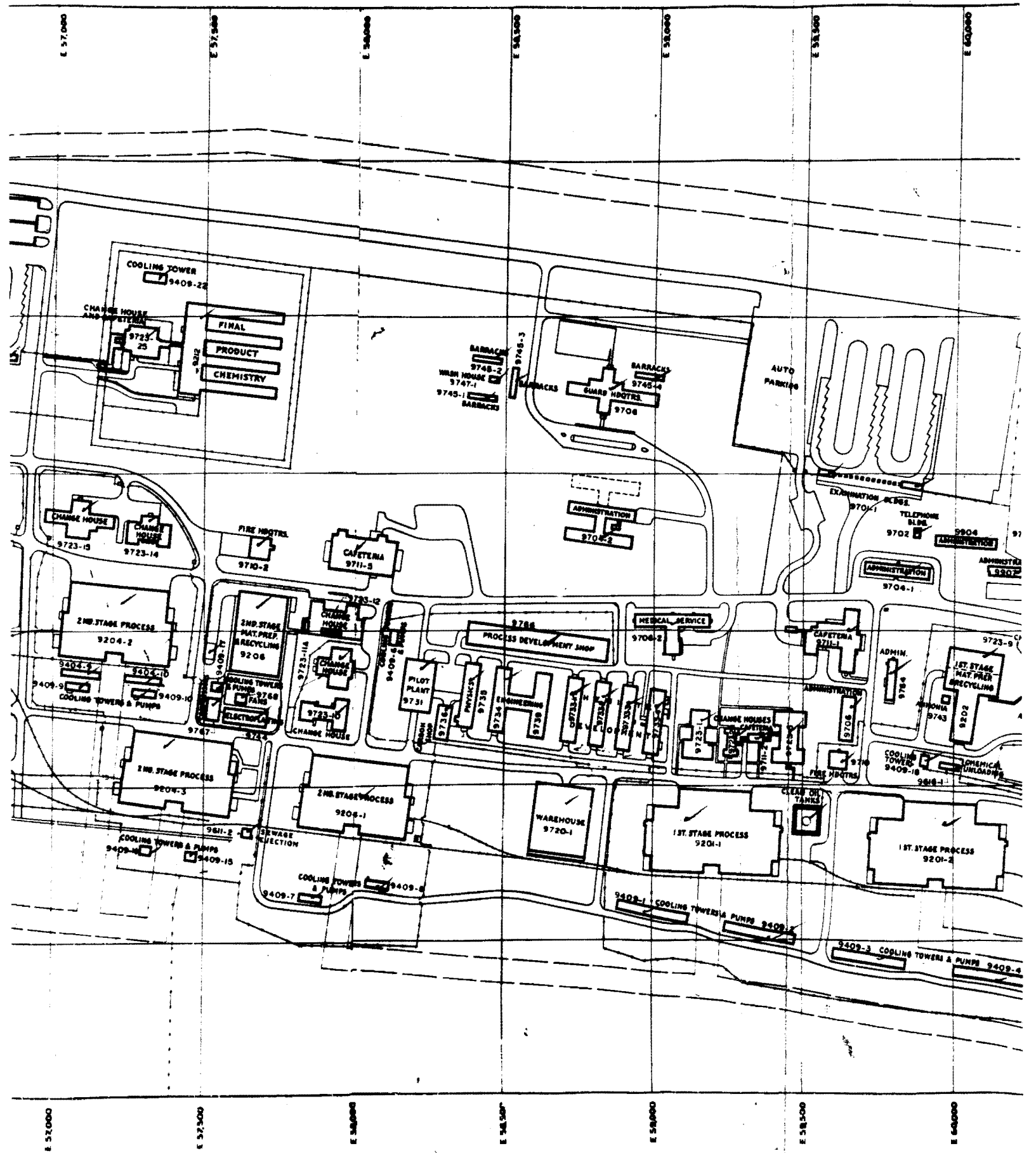

SECRET

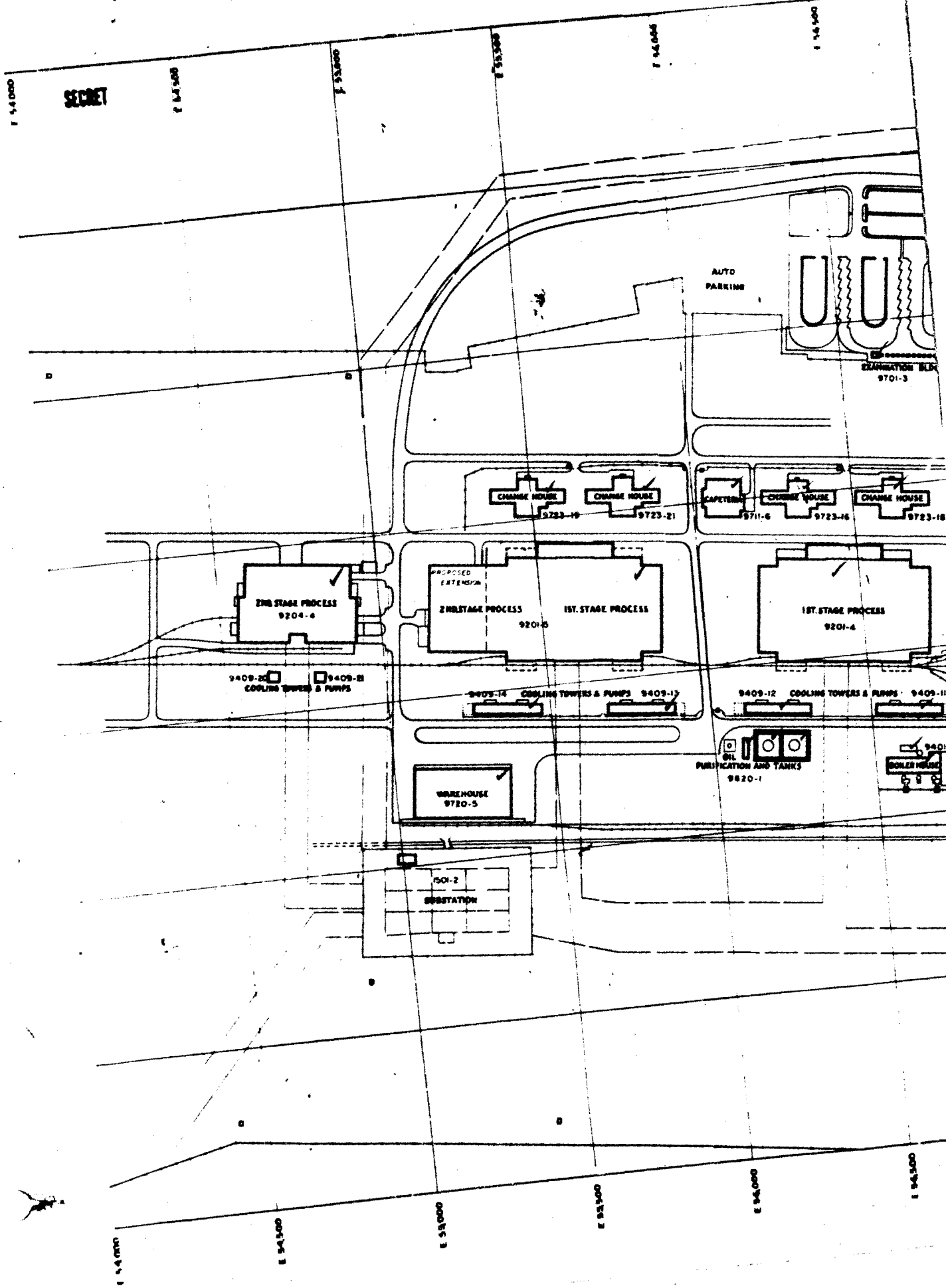

D-13

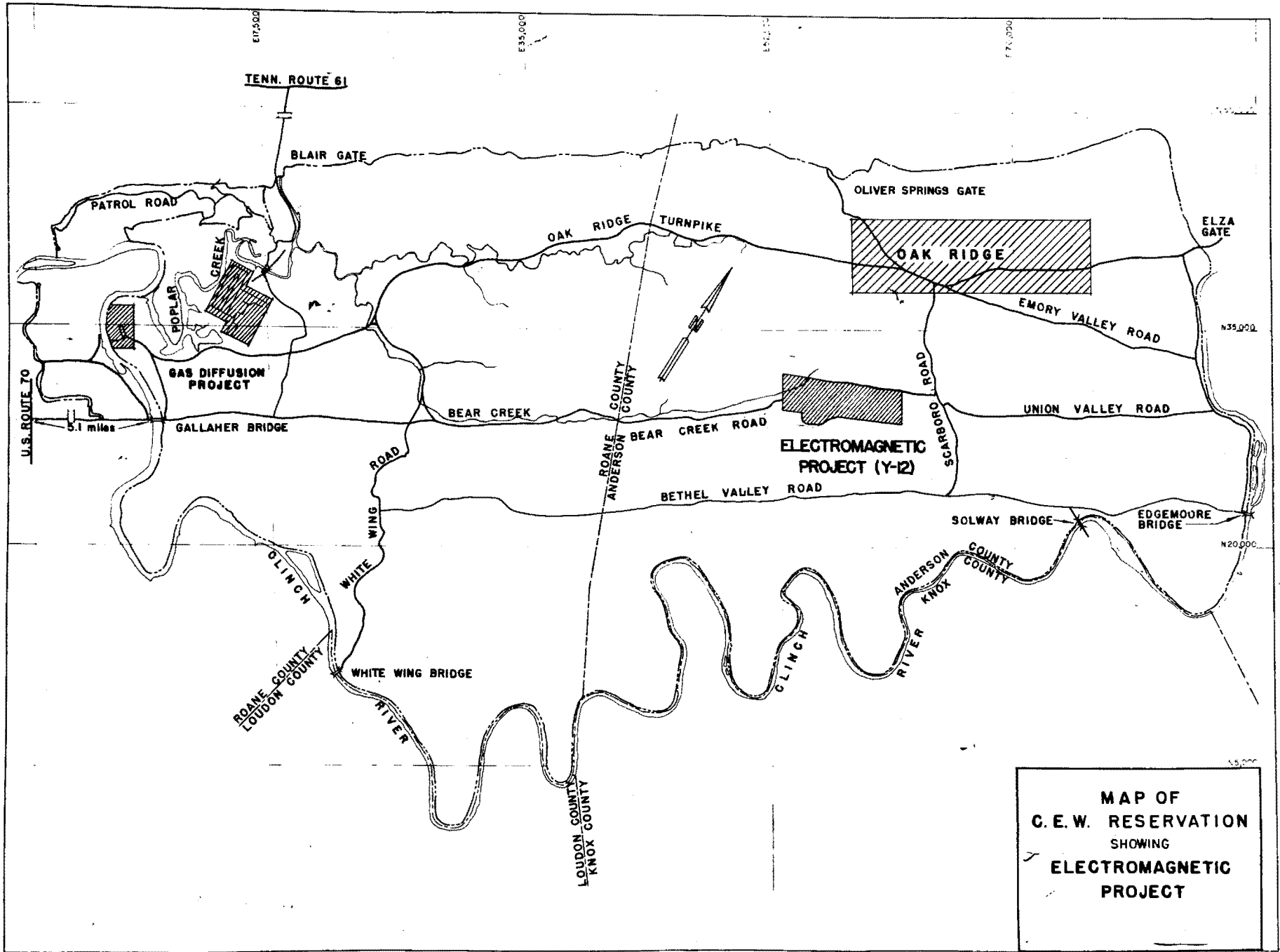

MAP OF
C.E.W. RESERVATION
SHOWING
ELECTROMAGNETIC
PROJECT

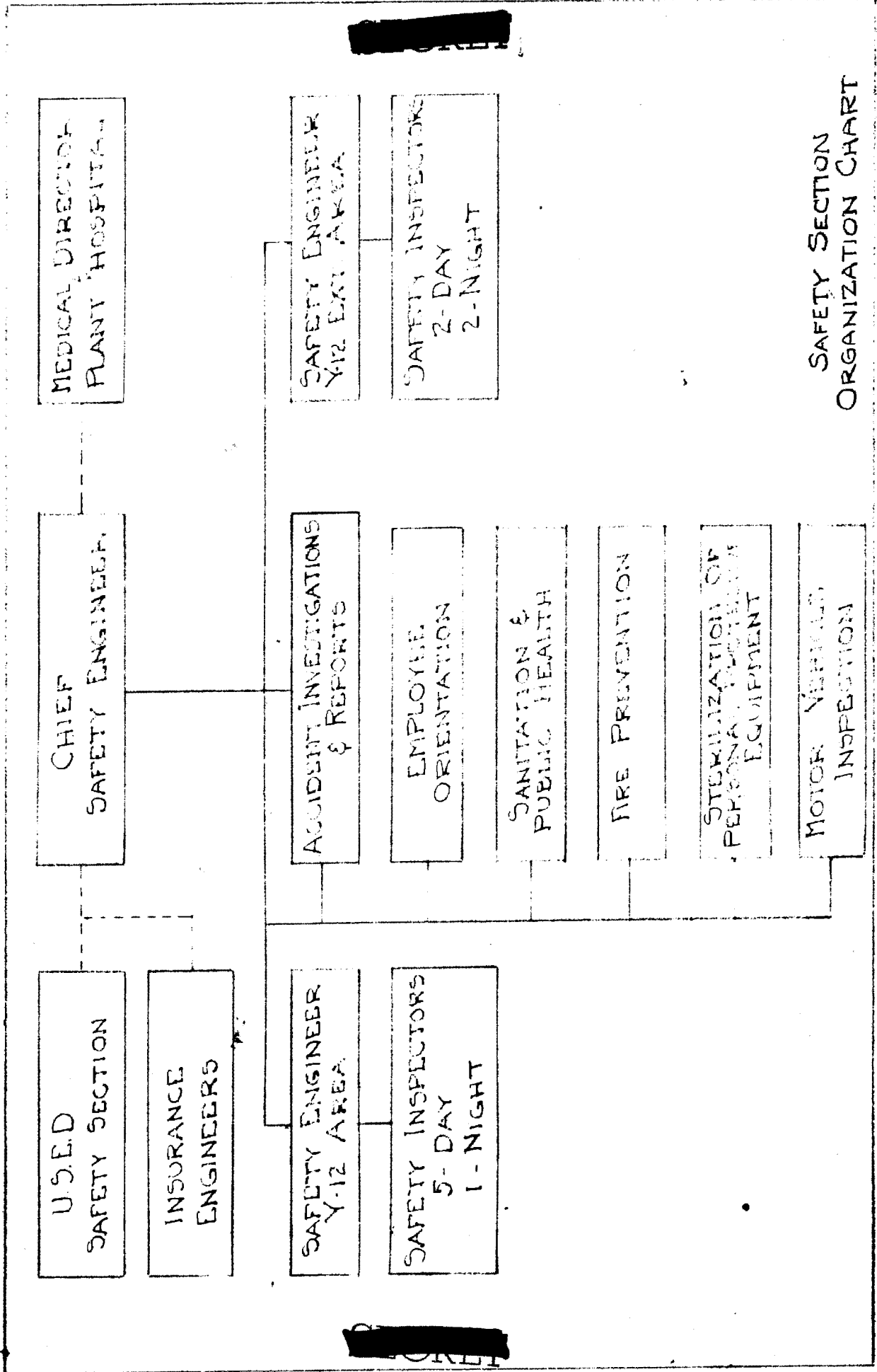

SAFETY SECTION ORGANIZATION CHART

<u>Number</u>	<u>Size</u>	<u>Purpose</u>	<u>Construction</u>
9		Pickling Tanks - Pickling Piping	Concrete floor with lead lining

c. OFFICE BUILDINGS

4	32' x 125'	Division Offices	Wood
1	40' x 228') 40' x 114') 8' x 48')	Main Area Office Building	Wood

d. CANTINES, QUARTERS BUILDINGS AND PORTABLE QUARTERS

10		Clock Alleys	Wood
1	30' x 96'	Time Office - Timekeeping and Payrolls	Wood
6	32' x 125'	Personnel Quarters and Change Houses	Wood
4	28' x 50' 8"	Lunch Centers	Wood with concrete floors
30	12' x 16'	Moveable Gang Shanties and Tool Rooms	Wood

[REDACTED]

TABULATION OF TEMPORARY BUILDINGS

Y-12 EXTENSION AREA

a. WAREHOUSES

<u>Number</u>	<u>Size</u>	<u>Purpose</u>	<u>Construction</u>
2	48' x 100'	Storage of Secret Material	Wood with Concrete
1	48' x 192'	" " " "	Floors with Concrete
2	60' x 200'	General Warehouses	Floors with Concrete
24	30' x 96'	" "	Wood (Sectional)
1	32' x 46'	Central Receiving - Material Receiving and Assignment	Wood

b. SHOPS

1	30' x 96'	Fabricate silver bus bar	Wood with concrete floor
1	48' x 272'	Fabricating Piping	Wood with concrete floor
1	60' x 200'	Carpenter Shop - Fabrication of Ventilation ductwork	Wood with concrete floor
1	48' x 192'	Sheet Metal Shop - Fabrication of Ventilation ductwork	Wood with concrete floor
1	48 x 128'	Riggers Loft - Storage and Maintenance of cable, etc.	Wood with concrete floor
1	60' x 200'	Paint shop - Storage and preparation of paint	Wood with concrete floor
1	53' x 200'	Valve reconditioning and paint shop	Wood with concrete floor
1	40' x 60'	Sand-blasting shop - sand-blasting pipe, cleaning and painting of piping and valves	Wood
1	48' x 96'	Plate shop - Fabrication of plates for track magnets	Wood with dirt floor

e. OFFICE BUILDINGS

<u>Number</u>	<u>Size</u>	<u>Purpose</u>	<u>Construction</u>
1	34' x 130'	Y-12 General Administration and Engineering	Wood
1	34' x 205'	Ditto	Wood
1	30' x 84'	Division Office	Wood
1	30' x 72'	Division Office	Wood
3	30' x 60'	Division Office	Wood
1	60' x 108'	General Piping Office and Shop	Wood
1	30' x 84'	Time Office - Timekeeping and Payrolls	Wood
1	30' x 60'	Personnel Office - Procurement and Terminations	Wood
22		Clock Alleys	Wood
1	30' x 48'	Headquarters, Beckwood Sprinkler Company	Wood
1	30' x 72'	Truck Dispatchers' Office	Wood
1	30' x 158'	Personnel Quarters and Change House	Wood
1	30' x 96'	Change House	Wood
1	25' x 102'	Change House	Wood
1	30' x 60'	Change House	Wood
1	30' x 180'	Change House	Wood
60	12' x 16'	Movable Gang Shanties and Tool Rooms	Wood
4	28' x 50'8"	Lunch Canteens	Wood

TABULATION OF TEMPORARY BUILDINGS

Y-12 AREA

a. WAREHOUSES

<u>Number</u>	<u>Size</u>	<u>Purpose</u>	<u>Construction</u>
1	30' x 60'	General Receiving Station Material Receiving and Assignment	Wood
1	48' x 110'	Covered Platform for storage of cable	Wood

b. SHOPS

1	48' x 96'	Plate Shop - Fabrication of plates for Track Magnets	Wood with dirt floor
1	48' x 96'	Machine Shop	Wood with con- crete floor
1	48' x 96'	Sheet Metal Shop - Fabrica- tion of Ventilating Ductwork	Wood with Con- crete floor
1	60' x 109'	Carpenter Shop - Finish Millwork and track enclosures	Wood
1	48' x 114'	Riggers Loft - Storage and Maintenance of cable, etc.	Wood with con- crete floor
1	60' x 107'	Riggers Lot Annex - Storage and Maintenance of cable, etc.	Wood
1	80' x 72'	Welding School	Wood
1	40' x 60'	Paint Shop - Storage and Preparation of Paint	Wood
1	30' x 60'	Sand Blasting Shop - Cleaning and painting Oil Piping and Valves	Wood
1	30' x 40'	Mortar Mixing Plant - Batching and Loading Bricklayers	Wood
1	32' x 35'	Boiler House - Steam Supply for Pipe Pickling Tanks	Wood
3	14' x 37'	Pickling Tanks - Cleaning of Process Piping	Concrete with Lead lining
1	32' x 84'	Valve Conditioning Shop	Wood

TABULATION OF TEMPORARY BUILDINGS

Y-12 AREA

a. WAREHOUSES

<u>Number</u>	<u>Size</u>	<u>Purpose</u>	<u>Construction</u>
1	60' x 150'	Cable Warehouse - Storage of Electric Cable, etc.	Wood
1	48' x 148'	Pipe Warehouse - Storage of Valves and Fittings	Wood
1	25' x 126'	Storage of Miscellaneous Construction Material	Wood
3	30' x 192'	Ditto	Wood
1	25' x 122'	Ditto	Wood
1	30' x 60'	Electrical Warehouse and Office - Supervision and Storage - Electrical Work	Wood
3	60' x 200'	Midway - Storage of Secret Equipment	Wood with concrete floors
2	48' x 192'	Midway - Storage of Secret Equipment	Ditto
1	30' x 60'	Storage of Cement	Wood
1	20' x 30'	Sand Storage	Wood
1	60' x 200'	General Warehouse - Storage of Miscellaneous Construction Materials	Wood
1	7' x 140'	Pipe Rack - Storage of small pipe	Wood
1	30' x 48'	Carpenter Warehouse - Storage of Mills, form ties, etc.	Wood
1	20' x 150'	Unloading Platform	Wood
1	25' x 160'	Lumber Shed - Storage of Dressed Lumber	Wood

Labor Relations, 5.1, ff
 Housing, 5.3
 Local Offices, 5.1
 Recreation & Welfare, 5.4
 Steppages, 5.5
 Transportation, 5.3
 Larson Process, 3.14
 Laundry, 3.15
 Letter Contract, 2.1
 Liquid Phase Process, 3.14
 Liquid Thermal Diffusion Plant, 1.4
 Louisville & Nashville R.R., 3.27,
 3.28, 5.4

Machine Shops, 3.15, 3.16, 3.32
 Manhattan District
 Key Personnel, 6.1, 6.2
 Marvel, P. I., 6.5
 Materials of Construction, 4.1 ff
 Construction Statistics, 4.4, 4.5,
 4.6
 Disposal of Scrap, 4.4
 Expediting, 4.1
 Peak Carload Receipts, 4.5
 Receipts & Distribution, 4.3, 4.4
 Midway Warehouses, 3.9, 3.28, 3.34
 Miller, Dr., 6.5

National Safety Council, 5.8
 New York, Ontario and Western RR, 5.4

Office of Price Administration, 5.4
 Oliver Springs Gate, 3.27
 Operation, Initial, 3.10, 3.11
 Organization & Personnel, 6.1, ff
 Assistance, Acknowledgement, 6.4,
 6.5
 Stone & Webster Engineering Corp.,
 6.2, ff.

Patterson, R. P., 5.2
 Patterson-Brown Plan, 5.2
 Personnel, Number of, 3.23, 5.2
 Powell, S. T., 3.8, 6.5
 President of United States, 1.1

Problems, foundation, 3.5
 Programs, Silver, 2.6, 3.35
 Purpose, General, 1.1

Reano-Anderson Company, 4.4, 5.4
 Rogers, Ralph Co., 3.36

Safety, 5.5 ff
 Accidents, fatal, 5.9
 Department Policies, 5.7
 Medical facilities, 5.8
 Obligations of, 5.6
 Statistics, comparative, 5.8,
 5.9

Schedules, 3.3, 3.5, 3.20
 Scope, General, 1.1
 Sealy, 6.5
 Security, 5.9, ff.
 Badges, Passes, 5.13
 Fingerprints, 5.13
 Fire, 5.10
 Guard Force, 5.9
 Intelligence and, 5.12, 5.13, 5.14
 Investigation, Personnel, 5.14
 Service Contract, work performed,
 3.29 ff

Sewage Treatment Plant, 3.24, 3.25
 Silver Program, 2.6, 3.35
 Solway Gate, 3.27
 Specialty Groups, 3.1, 3.2
 Steam Plant, 3.26
 Stone & Webster Engineering Corp.
 Boston Office, 4.1, 5.1
 Inspection & Expediting Dept., 4.1,
 4.2
 Key Personnel, 6.2, 6.3, 6.4
 Personnel Department 5.1
 Storage Reservoir, 3.24
 Subcontracts, 2.4, 2.5
 Supplements to Contract,
 W-7401-eng-13, 2.2, 2.3

Tanks, The walking, 3.11
 Tennessee Eastman Corp., 1.2, 2.3,
 3.8, 3.29, 3.33, 6.1
 Tennessee Valley Authority (TVA) 3.25

~~SECRET~~

MANHATTAN DISTRICT HISTORY

BOOK V - ELECTROMAGNETIC PROJECT

VOLUME 5 - CONSTRUCTION

INDEX

- Administration, 1.2
Administration Buildings, 3.15
Alpha
 I, 3.3, 3.8 ff
 Process Buildings, 3.3 ff
 Tracks, 3.9 ff
 Chemistry Buildings, 3.13 ff
 Magnets, 3.9 ff
Architect-Engineer-Manager
 (AEM), 2.1
Authorization, General, 1.1
- Beta
 Chemistry Buildings, 3.13 ff
 Process Buildings, 3.4 ff
 Tracks, 3.13, 3.20
Blair Gate, 3.27
Brand, 6.5
Brown, E. J., 5.2
Buildings, 3.3 ff
 Administration & Service, 3.15
 Alterations, 3.19
 Chemistry, 3.13
 Completion statistics, 3.16
 Extension, 3.16
 New Alpha, 3.18
 Temporary Facilities 3.33 ff
Bulk Treatment, 3.14
Bush, V., 1.2
- Cafeterias, 3.15
Chemistry Buildings, original
 construction, 3.13 ff
Chicago, Burlington & Quincy
 R.R., 5.4
Conant, J. B., 1.2
Contracts, 2.1 ff
 W-14-108-eng-49, 2.3, 3.28
 W-14-108-eng-60, 2.4, 3.23
 W-7401-eng-13, 2.1, 2.4, 3.28
- Contractor, Selection of, 2.1
Contractual Arrangements, 2.1 ff
Construction Program, 3.1 ff
 Schedules, Buildings 3.3 ff
 Statistics, 3.4 ff
Corning Glass Works, 3.22
Cost of Plant, 2.5 ff
Cubicles, 3.9, 3.19
- Description, General, 1.2
Development Plant, 3.3, 3.5, 3.7, 3.8
- Edgemoor Gate, 3.27
Elge, E. A., 6.5
Elsa Gate, 3.27
Expediting, Materials of construction, 4.1
Fences and Guard Towers, 3.28, 3.29
Filtration Plant, 3.24
Fire Stations, 3.15, 3.16
Ford, J. G., 6.5
Foundation problems, 3.5
- Gallaher Gate, 3.27
Gas Diffusion Plant, 1.4, 2.3, 3.23
Groves, Major Gen. L. R., 3.17
Guard Towers, 3.29
- Hanley & Company, 2.5 ✓
Hill, C. F., 6.5
Hospital, 5.8
- Initial Operation, 3.10

~~SECRET~~

Thermal Diffusion Plant, 1.4
Transit-Mix Concrete Corp., 3.28
Track, rebuilding the first, 3.11

United States Employment Service, 5.1
University of California Radiation
Laboratory, 6.8

Utilities, 3.23, ff.
Electric Power, 3.23, 3.26
Facilities, misc., temporary, 3.26
Fence, Interior & temporary, 3.28
Fence, Perimeter, 3.28
Fence & Guard Towers, 3.28, 3.29
Railroads, 3.27, 3.28
Roads, 3.27
Roads, Temporary, 3.27
Sewage Disposal, 3.24, 3.26
Steam Plant, 3.26
Temporary Facilities, 3.23
Water Supply System, 3.24

Vacuum Distillation, 3.14
Vapor Phase Process, 3.14

War Manpower Commission, 5.1
War Powers Acts, 1.3
Washington Liaison Office, 4.1
War Production Board, 4.1
Waters-Flagg Engineering Corp., 2.5
White Wing Bridge, 3.27
Widener, E. F., 6.8
Work Authorities, 3.20, 3.21
Cost of, 3.23

Y-12 Extension, 3.16
Young, H. H., 6.8

~~SECRET~~