

THIS FILE IS MADE AVAILABLE THROUGH THE DECLASSIFICATION EFFORTS AND RESEARCH OF:

THE BLACK VAULT

THE BLACK VAULT IS THE LARGEST ONLINE FREEDOM OF INFORMATION ACT / GOVERNMENT RECORD CLEARING HOUSE IN THE WORLD. THE RESEARCH EFFORTS HERE ARE RESPONSIBLE FOR THE DECLASSIFICATION OF THOUSANDS OF DOCUMENTS THROUGHOUT THE U.S. GOVERNMENT, AND ALL CAN BE DOWNLOADED BY VISITING:

[HTTP://WWW.BLACKVAULT.COM](http://www.blackvault.com)

YOU ARE ENCOURAGED TO FORWARD THIS DOCUMENT TO YOUR FRIENDS, BUT PLEASE KEEP THIS IDENTIFYING IMAGE AT THE TOP OF THE .PDF SO OTHERS CAN DOWNLOAD MORE!

Development of Automatic Telegraph Switching Systems

BY R. D. PARKER

Unclassified

There are two general types of automatic telegraph switching systems. In one, electrical circuits are established to provide communication paths between telegraph stations in customers' offices and are broken when the need for communication is over. In the other, direct electrical circuits between stations are not established, but coded information in messages automatically routes them through telegraph networks to their destinations. This paper describes briefly some of the systems now in use, and outlines some of the requirements which had to be met to provide a satisfactory service.

INTRODUCTION

A switch as used in electrical engineering is defined in dictionaries as a device for making, breaking, or changing the connections in an electric circuit. When a switching operation is performed, circuits are changed from one connection to another and devices are cut in and out of circuits. The idea is to transfer or shift these electrical circuits and devices around.

A telephone central office or exchange is an excellent example of the above, in that electrical voice-transmission circuits are shifted about to establish communication paths between parties, and are broken when conversations are over. Thus, a telephone exchange area such as the District of Columbia is operated as a large electrical switching system.

Telegraph circuits are established, broken, and shifted around like telephone circuits, and when telegraph circuits to subscribers' premises are connected and disconnected on requests from subscribers a telegraph exchange system is created. In telegraphy, however, another concept of switching has grown up. This is because telegraph messages, as contrasted with telephone messages, can easily be stored, held in transit, and re-transmitted sometime after reception. The pieces of paper or other message recordings are the things shifted or switched around. A telegraph office where messages on blanks are shifted from an incoming circuit to one or more of several outgoing circuits has been called a "relay" office, in that received messages are later transmitted to their destinations, but, such an office is also in fact a message-switching center. A "relay" office does indeed suggest a relay race,

in which a baton is handed at a point of exchange to the next runner; but this comparison fails to take into account the switching which is performed in telegraphy. If in a relay race each baton carried a coded message which had to be decoded at the exchange point to determine which runner of a group would carry a particular baton for the next lap and batons were passed accordingly the analogy would be more complete. This imagined reshuffling of batons is message switching.

In recent years a new technical development has permitted telegraph messages to be routed or directed *automatically* from their point of origin to their destination by means of coded electrical impulses which are in a sense part of the message but precede the normal address, the text, and the signature. An arrangement following this method of working, with a center where messages are stored, analyzed, and retransmitted, becomes, therefore, an automatic message-switching system. The circuit arrangements are fixed and the messages are switched. This operation may be electromechanical or electromagnetic, with messages stored by perforated tape, on magnetic tapes and drums or some other manner, but direct electrical paths between sending stations and addressees are never established.

Thus telegraphy, unlike telephony, has two types of switching systems, one, circuit switching and the other, message switching, each with its own problems. Accordingly, it is desirable to consider them under separate sections: Section I, Circuit Switching; and Section II, Automatic Message Switching.

SECTION I—CIRCUIT SWITCHING

GENERAL

There are two well established systems operating today in which printing-telegraph circuits are switched to provide direct communication paths between subscriber stations: one in America, known as Teletypewriter Exchange Service or TWX, and the other in Europe, started as a national service but now rapidly expanding on an international basis, and known as TELEX¹. TWX was initiated in the early 1930's and TELEX followed with the first installations in England.

Shortly after World War I, when the writer started the development of printing-telegraph switching systems for the American Telephone and Telegraph Company, he was informed by General J. J. Carty, who was then head of its Development and Research Department, that before

¹ TELEX is the abbreviation adopted by the Radio Corporation of America for its overseas Teletypewriter Exchange Service and associated TELEX stations in Europe and other areas.

the introduction of the telephone in the latter part of the 1870's a rather extensive telegraph switching system was in operation in New York City. In this system, Morse circuits from a central exchange radiated to customer's offices. Each customer hired a Morse operator, who handled messages and requested the central-exchange operator to make circuit connections to other customers. The advent of the telephone, saving the expense of the Morse operators, quickly put an end to this type of telegraph switching.

The actual introduction of a printing-telegraph switching or exchange public service had to wait for the development of a satisfactory start-stop type of telegraph printer, teletypewriter, teleprinter or, teletype machine, as it is variously called. It is reasonable to ask what is meant by "start-stop" and why it is important in planning an exchange system. Start-stop means a method of operating printing-telegraph machines in which the code group needed for selecting a character is preceded by an impulse, always of the same kind, which indicates to a receiver that a code group representing a character will follow immediately. This simple impulse is the "start". Furthermore the code group is followed by an impulse opposite in kind to the start, which brings the receiver to a rest condition in preparation for the next start impulse. This final impulse in the complete sequence for each character is the "stop". Sending and receiving machines do not operate at exactly the same speed, and without the start-stop feature a receiver would quickly gain or lose enough relative to a sender to cause errors in the received copy. A fresh start at each character keeps the machines in good relationship with each other and prevents these errors. Most printing-telegraph machines in use today operate on this principle. Such machines operating at about the same speed in words per minute and having like code character combinations may be freely interconnected by electrical circuits for a typed form of communication service. Thus, with the "start-stop" code a printing-telegraph circuit-switching system became feasible.

BELL SYSTEM TWX SERVICE

The Bell System established a public nation-wide printing telegraph switching service in 1931, following a long development and trial program. It was realized that little or no local business could be expected, and because of the necessity for recording and later billing customers for long distance calls, manually operated toll switchboards were especially designed for the service. All communications between toll-operators in distant cities, and between operators and subscribers, were made by means of printing-telegraph machines. The typed records proved to be of assistance to operators in spite of the slow speed

of the machines—60 words per minute—as compared with speech, and the time required to establish toll-connections was found to be essentially the same as that for manual toll-telephone service.

A simple intercity TWX connection is illustrated in Fig. 1. Station A in New York is electrically connected to Station B in San Francisco so that coded signals for typing and machine control purposes may be passed back and forth to give a typed-record form of communication service. A call is initiated by a subscriber's turning on the power switch of the teletypewriter station set. This signals the switchboard operator, who requests the number of the called party by operating the keyboard of a machine which is an integral part of the switchboard. The party originating the call types this information, the operator selects a trunk to the distant city and passes the called number by typing to the incoming operator, who connects the trunk to the called station line and rings the station bell. Toll tickets are made out for billing purposes as with telephone service. Disconnect signals are flashed to the operators by the act of turning off the power-switch at either subscriber's station.

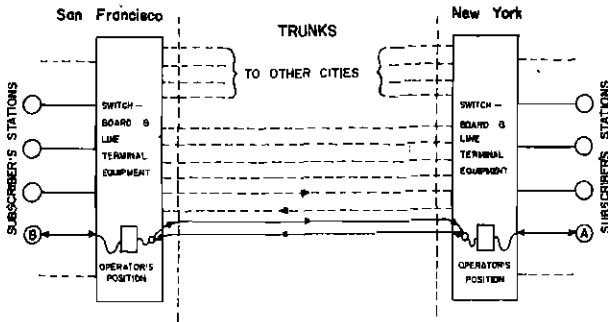

Fig. 1—Teletypewriter Exchange Service—Simple Intercity Call

When a connection such as is illustrated in Fig. 1 is established, subscribers may "talk" back and forth on a conversational basis, except that they use keyboards and their "conversation" is in typed form. A receiver may interrupt a sender and obtain control of the circuit by transmitting a "break signal" against the incoming signals and "locking out" the sending keyboard. Station equipment with perforated tape may also be employed where considerable message traffic is handled.

Over the years, automatic features have been added to the original manual scheme, and in many cases certain switching operations are

performed under the control of impulses transmitted over the communication circuits. An example is the use of a "concentrator", placed in a local area where a number of TWX subscribers are grouped. The concentrator is arranged to associate these subscribers automatically with trunks to a main TWX switchboard at some distant point.

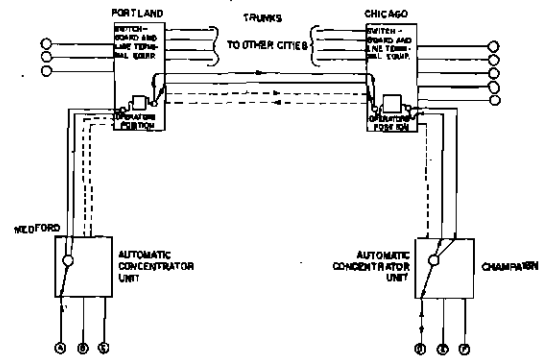

Fig. 2—Teletypewriter Exchange Service—Intercity Connection Using Automatic Concentrators

A connection between two TWX subscribers, involving the use of concentrators, is illustrated in Fig. 2. In this case a subscriber in Medford, Ore., is connected to one in Champaign, Ill. Since there is little demand for local connections, and not enough business at these towns to warrant installing a TWX manually operated switchboard, they are served by automatic concentrator units which pass calls to and accept calls from some larger switching center,—in this case Portland and Chicago. Thus, a call originating at Medford is automatically passed to an operator at Portland, over one of a comparatively small group of trunks. The operator at Chicago, on learning that the call is for a station in Champaign, selects an idle trunk to that city, and picks out and rings the called station automatically by sending code combinations from her keyboard. Disconnect signals originate as soon as the subscribers turn off the power switches at the teletypewriter sets.

Actually there are about 50 TWX stations in Medford and a much smaller number in Champaign. Satisfactory service is given by the use of concentrators, with about 10 trunks between Medford and

Portland and 3 between Chicago and Champaign. Thus concentrators save line charges by eliminating individual circuits from large switching centers to distant subscribers.

TWX service includes the establishment of conference connections, in which a large number of sending and receiving stations scattered over the country may be associated together for intercommunication in typed form. It also provides service to unattended stations, with means for starting and stopping the machine motors so that messages may be left when the receiving party is absent, as well as other features of importance to customers.

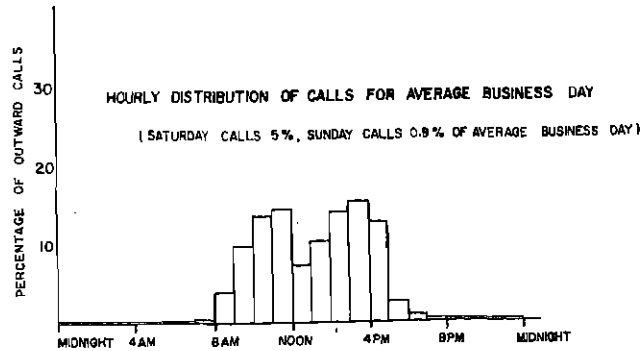

Fig. 3—TWX Outward Calls

There are now about 40,000 TWX stations in this country. The service requires several million miles of telegraph circuit facilities with about 130 manual-switching centers and 120 with concentrator units. These facilities cover the Nation, so that a TWX station may be set up at practically any point. A service of this character labors under the disadvantage that it is a business tool and follows business hours. Thus Fig. 3 shows the hourly distribution of TWX outward calls during a business day, averaged for 25 large American cities. The evening load is very light, and calls on Saturdays and Sundays are only a small percentage of those on a business day. Another disadvantage is the high cost of station equipment, which is much more expensive than a telephone set. However, since 16 or more telegraph channels can be derived from a single telephone facility, TWX toll-charges are low. Thus the toll-charge for a 3 minute TWX call is considerably less than that for a weekday person-to-person telephone connection between the same cities.

EUROPEAN AND INTERNATIONAL TELEX SERVICE

The British initiated what they called TELEX service in England not long after TWX service was started in the USA. At first a telephone subscriber was provided with a printing-telegraph machine, so that he could either talk or type over a telephone connection, provided of course that the distant party had a similar machine. The telephone switching and transmission plant was common to both services. This was contrary to the American scheme, which started and still has switching and transmission facilities for telegraphy distinct from those for telephony. Because of the large private-wire telegraph system already existing in America before TWX was started—and because tests of the operation of teletypewriters through telephone switching systems then in common use demonstrated that printing-telegraph service over these facilities would be unsatisfactory—the decision to have separate telegraph facilities for the TWX service seemed proper. As a matter of fact the British soon became aware of difficulties, and abandoned the idea of providing an alternate "talk or type" form of service through the normal telephone plant.

It is reported that the first international European TELEX connections were made in 1933 between stations in Holland, Belgium and Germany, using telephone circuits for telegraph facilities. For many years there was considerable controversy in European circles as to whether or not the International TELEX network as then foreseen should be established over telephone or telegraph facilities. After the War it was finally decided (CCIT, Brussels, 1948) to adopt the word TELEX and to use telegraph circuits. It is believed that the unsatisfactory service experienced by those countries, such as England, which tried out TELEX service as an adjunct to the telephone had much to do with this decision. However, with the introduction of toll-dialing and the provision in turn of more stable telephone circuits, it may well be that economies will be achieved by a closer association of telegraph switching with the telephone plant.

European Switching Arrangements

As might be expected, the various European telegraph administrations have adopted different switching methods for TELEX service, though a large percentage use some type of automatic method. Thus in Western Germany, which has been most active since the War in developing automatic printing-telegraph exchange service, there were over 100 automatic exchanges in use towards the end of 1954. These German exchanges employ the time-honored telephone dial, as do the systems in England, Denmark, Sweden and Finland, to enable subscribers to establish the desired connections. It is reported, however,

that the automatic systems in France and the Netherlands employ the keys of the teleprinter machine to generate 5-unit switching pulses, and a paper presented at an engineering meeting in Rome last year described the TELEX system in Italy as one which also makes use of the teleprinter keyboard for generating switching signals. Manual methods are still employed in some other countries, and it is evident that with international traffic it may be difficult to establish, and properly charge for, connections which are built up on a completely automatic basis.

Rate Structure

As with toll-telephone usage, rates for TELEX service have been established on a time basis, with three minutes as the usual minimum period. However, the trend appears to be to abandon this minimum period and base the charge on the actual use of a given circuit in time-steps of five seconds each, as registered on a call meter. In general TELEX connection will cost a subscriber about half the telephone charge.

Growth

The expansion of International TELEX service since the War is shown in the following table, made up from figures for 22 countries, published in the *Telecommunications Journal*, UIT, September 1956.

Annual International TELEX Traffic in Chargeable Minutes

1946	1947	1948	1949	1950
700,000	1,700,000	2,800,000	3,700,000	8,400,000
1951	1952	1953	1954	1955
14,700,000	23,300,000	32,700,000	52,700,000	72,240,000

The above figures include service to the United States, which started in 1950 with 16,000 chargeable minutes for that year and grew to over 800,000 minutes in 1955.

TELEX Subscriber Stations

It has been difficult to obtain reliable figures for the number of world-wide TELEX subscriber stations in use today, but if the 40,000 TWX subscribers in this country are included the total cannot be far below 100,000. The number is apparently growing very rapidly, and claims are made that it increases by 10 to 20 per cent each year.

International Service with Radio Links

Since the charge for a TELEX connection is based on the duration of the call, a non-stable radio link, causing errors in the typed copy and delaying communications, is most unsatisfactory to customers. However, the development and application of error detecting and correcting codes, coupled with the provision of the necessary circuitry for eliminating from the service-charge period the delays arising from transmission difficulties, has permitted radio links to be used with success.

TELEX traffic was first handled, it is reported, over radio links in 1950, when subscribers in Holland were connected to RCA teletype-writer machines in New York. As indicated above, this transoceanic service, called TEX by RCA, has expanded greatly since that time. Though the 5-unit start-stop code is practically standard throughout the World, certain differences between the machines in this country and those in Europe had to be taken care of before this intercontinental TELEX service could be furnished. An important difference in the matter of speed. While it is usual to talk and write about a speed of 60 words per minute, neither the American nor the European machines operate exactly at this rate. Furthermore, European machines run a sufficient amount faster than American to require the introduction of a punched-tape type of automatic repeater in any inter-continental circuit connecting two of these stations.

In 1956 arrangements were completed to permit any station of the U. S. TWX network (40,000 stations) to be connected via RCA TEX service to any of the then approximately 27,000 teleprinter stations in 26 overseas countries. Since the keyboards of many of the machines of these networks are not exactly alike it was necessary to provide automatic conversion apparatus to change the form but not the meaning of certain characters. RCA reports these conversions on transatlantic calls to be as follows:

When a TWX customer transmits to a TEX teleprinter, the following conversions will be made:

$\frac{5}{8}$	will be received as	-5/8
$\frac{1}{8}$		-1/8
\$		DLRS
$\frac{1}{4}$		-1/4
&		AND

*The dash before the fraction, as typed on European machines, is considered important to give a distinctive separation between a whole number and its fraction.

upper case H	(Trips the "Answer-Back" mechanism)
1	
2	-1/2
3	
4	-3/4
7	
8	-7/8
3	
8	-3/8
" (Quotes)	" (2 Apostrophes)
/. (Combined)	+? (Combined) *

When the overseas party is transmitting from a TEX keyboard to a TWX machine, the following conversions will be made:

? will be received as	QUERY
:	COLON
✱	WHO R U
(PAREN
)	PAREN
' (Apostrophe)	, (Coma)
=	-- (2 Hyphens)
+	/- (Hyphen, Stroke, Hyphen)
+? (Combined)	/. (Combined)

The automatic "Answer-Back", obtained when a TWX subscriber sends upper-case H to a teleprinter, is considered an important feature of equipment used in Europe and other countries, since a machine equipped with this feature automatically transmits an identifying code-signal at the request of a calling station.

International TELEX and TEX services have become an exceedingly important phase of international communications. The basic plan was to provide a service that would appeal to customers because of low cost, reliability of transmission, and the speed with which connections would be established. The idea was to establish a sufficient

* This symbolizes to an overseas party that the TWX sender has completed a message and is awaiting a reply.

number of trunks between exchanges so that even during the busy hours little or no delays would be experienced. It seems that in this case these fundamentals of a good communication service are paying dividends.

SECTION II--MESSAGE SWITCHING

GENERAL

The circuit switching systems considered thus far, such as TWX, TEX and TELEX, give a conversational to-and-fro type of printing telegraph service. They require the establishment of certain common arrangements before a satisfactory service of this type can be given. Telegraphy, however, has not been thought of, nor noted, for giving such an intercommunication form of service. It has been considered rather as a means of providing a record to be read, answered if necessary, and stored for future reference. Thus the sender of a telegram gave an address, wrote a signed message, and turned it over to a telegraph organization for transmission and delivery. The address routed the message through a network of circuits, and messages received at a network center would be passed manually to sending operators of other circuits. The need for incoming and outgoing circuits to operate in some common fashion was not too important.

When printing-telegraphy became common and machines for perforating tape with coded characters were available, the idea of receiving messages in perforated-tape form to be used later in the sending equipment of outgoing lines of a message center came to the fore. In this case operators read the addresses from the perforated tape to learn the proper routing. Later, machines were produced which typed the characters on the tape as well as punching them. This made the routing decision a little easier. It is apparent that a common method of working had to be adopted for these incoming and outgoing circuits. Just before and during the War a number of very large message switching centers based on manually handling tape were installed. Some are still in use. They are called "torn tape" centers, since each perforated tape message is torn from a roll of tape after reception.

In the 1920's, long before TWX service was established, it had become common practice in private-line teletypewriter service to control automatically the switching of circuits in terminal and other offices by coded impulses transmitted prior to message information. Electrical contacts associated with the mechanism in teletypewriter machines were used for switching purposes. It was not too great a step therefore to suggest that all messages in a telegraph network carry coded information which would route them through to their destinations

without human aid and thus establish a fully automatic printing-telegraph message-switching system.

It is believed with considerable certainty that the first automatic switching system of this type ever installed for service was made in 1940 by the Bell System for the General Electric Company, with the message center in Schenectady. A second and larger system, with the message center in Cleveland, was put into service for the Republic Steel Corporation in 1941, just before Pearl Harbor.

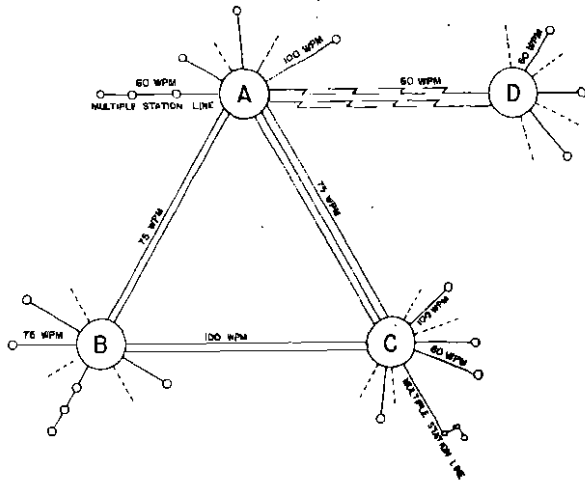

Fig. 4—Automatic Message Switching Network

Fig. 4 illustrates an automatic message-switching network, with message centers A, B, C, and D, and gives an indication of some of the complexities which arise. D enters the network via radio links, while A, B and C are tied together by land-line trunk circuits. (Many of the networks of this type are used by business houses and government agencies.) Each center may have 60 or more local circuits connecting it with sending and receiving stations. These circuits usually operate on a full duplex basis, sending and receiving simultaneously. There are three word-speeds in common use in this country today, namely 60, 75, and 100 words per minute. Since the rate charged by telephone and telegraph companies for a given circuit increases with the speed, it is the usual practice to select the most economical speed of working

with due regard to the volume of traffic to be handled. Furthermore the desirability of having several stations on a line, or a "party line" type of operation, becomes apparent when in planning a network it is found that several stations are in a group several hundred miles from a center.

Over the past 15 years two general schemes for assembling and using equipment in an automatic message center have been evolved. In one, the plan of having "In" and "Out" circuits, each circuit having individual telegraph terminations, has been carried out. In the other, more use is made of shared equipment. Thus, though each incoming circuit has its individual printing-telegraph apparatus, outgoing circuits do not. On the contrary, a common bank of outgoing equipment units is provided, any one of which may, in theory, be associated with any outgoing circuit and accessible to any incoming circuit. A saving in equipment may therefore be expected. In view of different line-speeds and other matters, difficulties enter this scheme which will be touched on later.

MESSAGE FORMAT

Given that the passage of a message through a switching center must be under the control of teletypewriter characters, a simplified message format is as follows:

- (1) Start-of-message characters (e. g. ZCZC)
- (2) Channel and message numbers
- (3) Signals to call attention to high precedence messages; e. g. Figure-shift followed by 5 J characters, 5 S characters, and letter-shift
- (4) Two message-precedence characters
- (5) Routing characters (routing indicators) followed by a routing-indicator termination
- (6) Text of message, including address and signature
- (7) End of message characters (e. g. 8 line-feeds and 4 N's)

CROSS-OFFICE OPERATION—"IN" AND "OUT" CIRCUITS

The circuits of a message center operating in accordance with the first plan outlined above and handling messages with formats similar to that just outlined are shown schematically in Fig. 5, while Fig. 6 is a photograph of such a center. Incoming lines in Fig. 5 are at the left, outgoing at the right. Each incoming message is recorded in punched as well as typed form by a typing-reperforator machine. Each such recorded message is read by machines marked T in the diagram. In some installations these devices will read or sense the last character of a given message in the received tape, though this character is closely

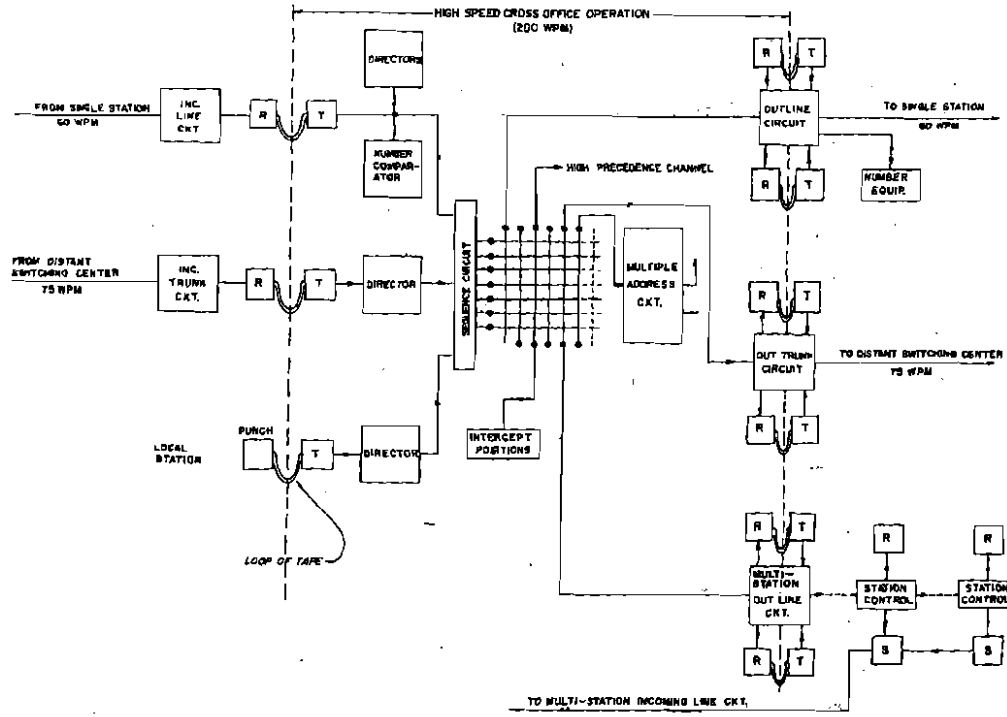

Fig. 5—Message Switching Center.
Cross-Office Operation From Incoming Lines to Outgoing Circuits



(Courtesy of the American Telephone and Telegraph Co.)

Fig. 6—Message Switching Center.

adjacent to the punches of the perforating mechanism. In others it is necessary to "feed out" several inches of tape to permit the last message character to be sensed. Immediately following the receipt of the start-of-message (SOM) characters it is a fairly common, though not a universal, practice to check the channel and message numbers to make certain that a proper message-numbering sequence is being followed.

As noted below, it is a military custom to have six message-precedence classes, but in the transfer of messages from "In" to "Out" lines in the message-center it is now the practice to divide messages into two precedence classes: high and low. The arrival of a high-precedence message at a center causes alarms to be given to alert the attendants. The precedence characters which control switching operations follow. The routing characters will usually consist of several characters for each addressee, and for several addressees these may add up to 50 or more, terminated by a special group. The text of the message, with the address and signature, follow in a routine manner, to be ended by a special end-of-message (EOM) character group which prepares the equipment for the next message.

Incoming line-readers (marked T) read one character at a time, and it is apparent that several characters have to be sensed before a decision

as to the next procedure can be made. Thus information must be stored and used later. Telephone-type relays have been used for this purpose, and directing-equipment and sequence-circuits may be assemblies of relays and switches. The objective is to connect the transmitter associated with the reader of an incoming line circuit with a recorder-reperforator associated with the proper outgoing line or trunk. As soon as routing information is analyzed, the director controls switching operations to make this connection through some type of mesh or grid as illustrated, or by other means. Once this path is established the message is transmitted across the office to one of two receivers, whichever is idle at the moment, associated with an outgoing circuit; two are installed to prevent traffic delays. The speed for cross-office traffic in recently established centers is 200 words per minute, but it is apparent that the rate at which a given message leaves a center is not determined by the cross-office speed but by the speed of the outgoing line to which it is sent. As indicated, the receivers of outgoing circuits pass perforated tapes to transmitters, which operate alternately for fast traffic handling.

PRECEDENCE TRAFFIC

Automatic message-switching systems can readily handle precedence traffic. In the Military installations now taking form messages will have six degrees of precedence. These, with their character designations, are Flash (ZZ), Emergency (YY), Operational Immediate (OO), Priority (PP), Routine (RR) and Deferred (MM). However, as mentioned above, for cross-office operation in the switching center only two classes, High and Low, may be recognized. In some instances the three top precedence designations of the above list will be rated High, the others Low. On the other hand, when messages are transmitted on outgoing circuits all six degrees of precedence, as well as the time that any given message has been in the office, may be considered to determine the order in which the messages will be sent out.

Since there are at least three different engineering groups in this country developing telegraph message-switching systems, variations in the general plan are bound to occur, and this has been true as regards the handling of precedence messages. In some installations a message of low precedence is not transmitted across the switching office until it is fully received. A high-precedence message, however, cannot suffer such a delay, and is started across the office as soon as the director, operating from the routing indicators, switches the message to the proper outgoing line or to a special high-precedence channel. In another plan all messages are started across the office as soon as the routing determinations have been made.

Again, different plans are followed for handling precedence messages at the outgoing line terminations. In one case the action taken on the arrival of a high-precedence message at an out-terminal then handling a message of low precedence is to interrupt this message and insert the other in its place. An alarm indicates that such action has been taken, and an attendant later puts the interrupted message back into the system. According to another method no message is interrupted, but the high-precedence message seizes the line ahead of any waiting message of lower grade as soon as the line is free.

MULTIPLE-CALL MESSAGES

A message to a large number of addresses will be handled by an automatic switching center if the routing indicators for each addressee are properly inserted in the format. The director and other equipment handling a given multiple-call or address message has the problem of assembling all the necessary outlets as designated by the routing indicators, so that when the message is forwarded from a transmitter all addressees will receive a copy. The equipment and circuit arrangements provided by the different development organizations to meet the requirements for handling multiple-address messages differ quite radically.

MULTIPLE STATION LINES

Mention has been made of the desirability of providing several stations on a given line to save line costs. In some instances as many as 10 stations on a line may be provided, but the difficulties involved in handling traffic to and from lines with as few as three stations will be evident from a consideration of Fig. 7. This shows a three-station

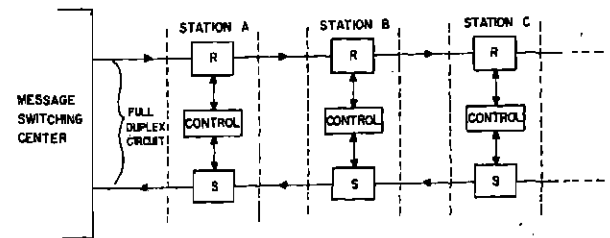

Fig. 7—Multiple Station Line

line being operated full duplex (i. e., with simultaneous operation of send and receive channels) with sending and receiving equipment at each station. It is evident that only one message at a time can be

UNCLASSIFIED AUTOMATIC SWITCHING SYSTEMS

received at either A, B, or C. Furthermore if a message is destined for C only, receivers at A and B should be inactive—actually locked out.

As regards sending, it is also clear that when one station is operating; the others cannot. Furthermore, if the traffic load is approximately uniform it is desirable to prevent one station from unduly holding the circuit. Signals may therefore be automatically transmitted from the center to start transmitters at station in rotation. A station without traffic—no tape in its transmitter—will be passed, and the next station tested for traffic.

INTERCEPT OPERATION

Differences in operating periods because of time zones, holidays and other factors bring about the need for the interception of messages at switching centers and transmission to addressees at later times. Thus a director may be so arranged that any message with a particular routing indicator will be sent to an intercept station in the center. Furthermore, any message with an unassigned routing indicator will be automatically transferred to intercept, and alarms sounded.

AUTOMATIC NUMBERING AND TIMING OF MESSAGES

The usual requirement is that all messages leaving a center are numbered and timed automatically, which means that the normal flow of characters is interrupted while symbols conveying this information are inserted.

CROSS-OFFICE OPERATION—POOLED EQUIPMENT

Fig. 8 diagrams sketchily an office of this type. Incoming lines each with typing reperforators, tape transmitters, relay banks and other apparatus are at the left, while outgoing lines with numbering and timing machines are at the right. For each group of about 25 incoming lines there is one common director with an associated translator. This relationship depends on the type and number of messages to be handled in a given busy period.

Each of the common cross-office units has a reperforator for receiving from incoming line units and a tape transmitter for sending to outgoing lines. Of course arrangements to meet all the different traffic situations must be provided. If all lines were operated at the same speed and no other variations, such as single and multiple station lines, were encountered, it is evident that *any* non-busy cross-office unit would be accessible to *any* incoming line and transmit in turn to *any* non-busy outgoing circuit. Thus a pool of cross-office units is available on call, and the plan appears economical when compared with the first scheme, in which *each* outgoing line has its own teletypewriter terminal equipment.

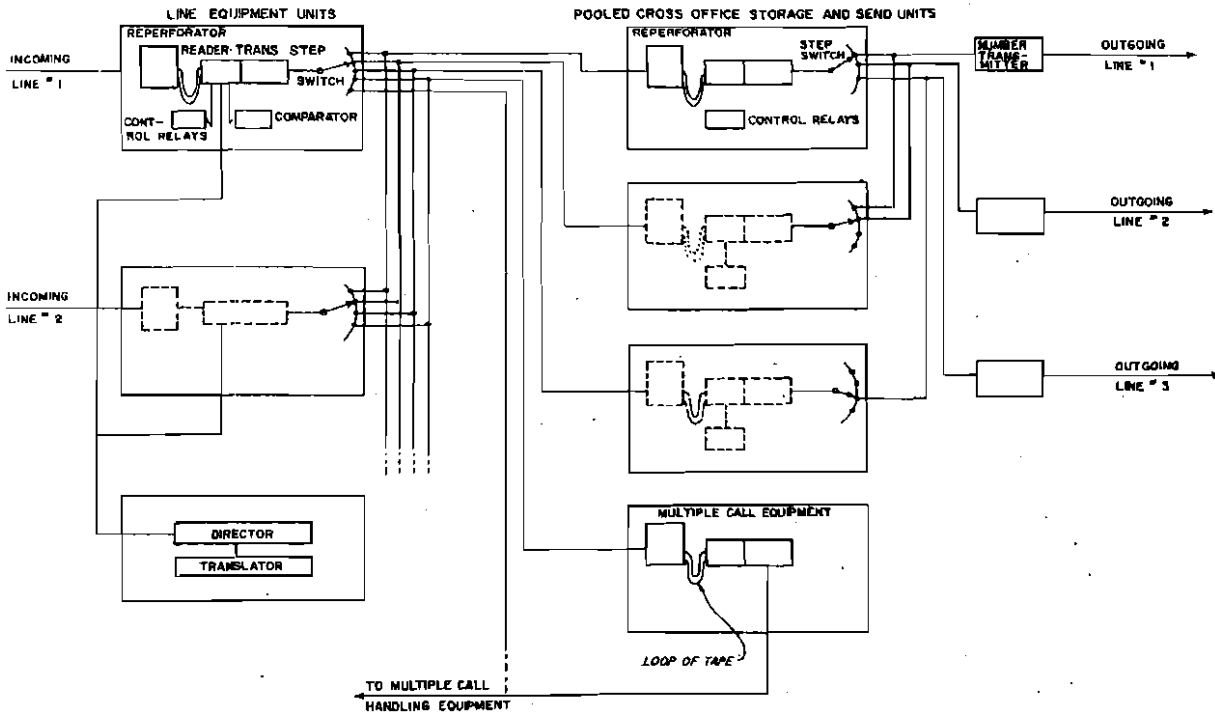

Fig. 8— Message Switching Center. Cross Office Operation Using Pooled Equipment

Complexities arise however when lines of different word speeds terminate in the same office, and an equipment pool is required for each speed.

The Army is proceeding with its network on the basis of pooled apparatus, while the Navy and the Air Force have equipment based on the other scheme. It will be some time before the relative merits of the two arrangements will be completely thrashed out.

TRUNKING CIRCUIT DETERMINATIONS

The number of trunks needed between two switching-centers to provide satisfactory service, bearing in mind the economics of a given situation, becomes a problem in probability. The quality of service to be given, i. e. the amount of allowable message delay, must be considered in connection with busy-hour loads, length of messages, cost of trunks and other factors. In some message-switching systems practically all messages are short, so that routing indicators and the like constitute a fairly large percentage of the message. Also many of these short messages—e. g. air traffic control messages—must be delivered very quickly or their value is lost. These and other considerations have a bearing on the determination of the number of trunks to provide for a particular case.

SECURITY WITH MESSAGE SWITCHING SYSTEMS

It is evident that characters used for switching purposes must enter a switching office in the clear. Also, if traffic-flow security is to be achieved, these characters must *not* be in the clear on lines between centers and from outlying stations to centers. To meet these two requirements all such circuits will have to be furnished with cipher equipment on a center-to-center and station-to-center basis, giving what has been called "link encipherment". The body of a message will be in the clear while it is passing through the switching office, unless the message has been doubly enciphered.

CONCLUSION

It seems evident that while message-switching systems are economical of plant facilities and especially of long distance circuits, they introduce a host of other problems in that they must handle different types of messages with a variety of precedence values and at different speeds. If long circuits needed for printing-telegraphy were plentiful and cheap it would seem that the direct-circuit method of switching would be preferable. Here the problem of handling various types of messages falls back on the user of the service, and the switching system rids itself of that burden. Moreover, users with direct connections between their

terminals should receive better over-all service than those who depend on having their messages handled by a second party, even though that party is an automatic mechanism.

It is believed that the great expansion of telephone service which has occurred when trunking circuits and other facilities are provided on a liberal basis to give virtually a no-delay service is an indication of what could happen to "printing-telegraphy" if connections between teletype-writer stations anywhere in the world could be established in a similar fashion.

Appreciation is expressed for the work of those who very kindly read the draft of this paper and offered their comments.