

Chapter 9

Air Compressors and Pneumatic Tools

When air is compressed, it receives energy from the compression. This energy is transmitted through a pipe or a hose to the operating equipment, where a portion of the energy is converted into mechanical work. A compressed-air system consists of one or more compressors together with a distribution system to carry the air to the points of use. Engineer units use compressed air to inflate rubber equipment, to spray materials, to operate pneumatic tools, to clean equipment, and to perform certain jobs in maintenance shops. A pneumatic tool uses the energy of compressed air as the power for its operation.

AIR COMPRESSORS

9-1. Portable air compressors are commonly used on construction sites where it is necessary to meet frequently changing job demands. *Figure 9-1* and *Figure 9-2*, page 9-2, show two types of air compressors. The capacity of an air compressor is determined by the amount of free air that it can compress to a specified pressure in one minute, under standard conditions (absolute pressure of 14.7 pounds per square inch [psi] at 60°F). This amount of free air is usually expressed in cubic feet per minute (cfm). The number of pneumatic tools that can be operated from one air compressor depends on the air requirements of the specific tools.

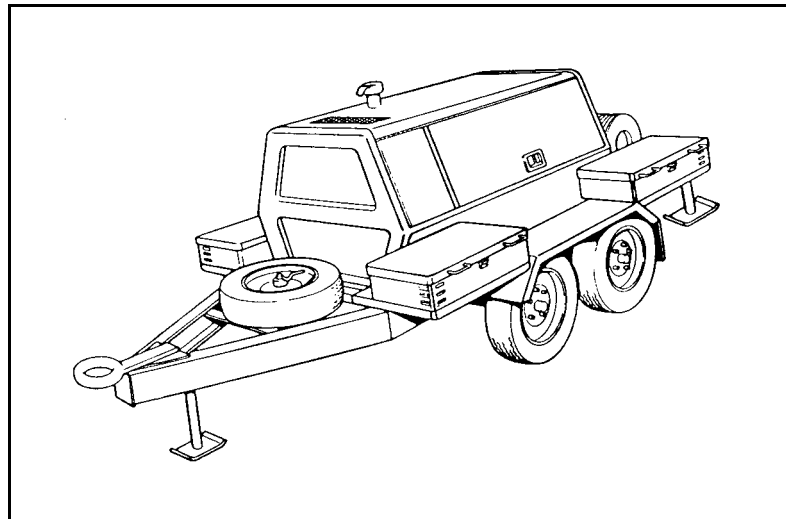

Figure 9-1. Trailer-Mounted, 250-cfm Air Compressor

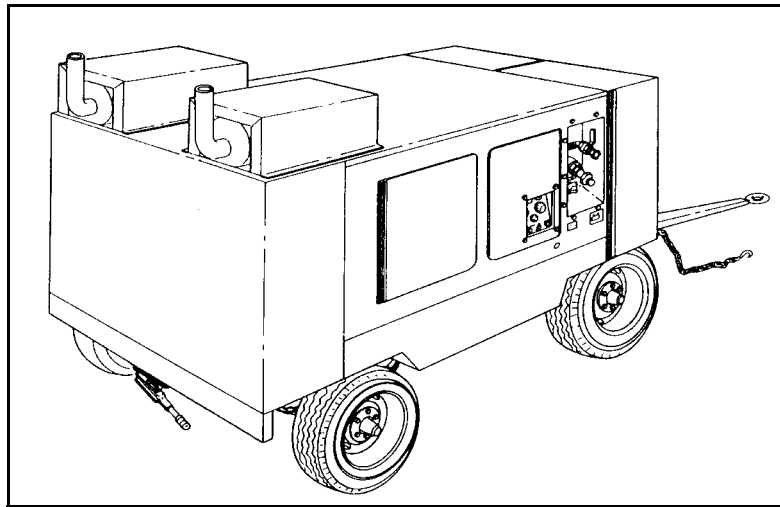

Figure 9-2. Wheel-Mounted, 750-cfm Air Compressor

EFFECTS OF ALTITUDE

9-2. When a given volume of free air is compressed, the original pressure will average 14.7-psi absolute pressure at sea level. If the same volume of free air is compressed to the same gauge output pressure at a higher altitude, the volume of the air after being compressed will be less than the volume compressed at sea level. Thus, while a compressor may compress air to the same discharge pressure at a higher altitude, the volume supplied in a given time interval will be less at the higher altitude. *Table 9-1* shows the percentage of volumetric efficiency at different altitudes based on a 100-psi gauge output pressure.

Table 9-1. Efficiency of Air Compressors at Various Altitudes (100-psi Gauge Output Pressure)

	Single-Stage Reciprocating Compressor	Two-Stage Reciprocating Compressor	Rotary Compressor
Altitude (Feet)	Percent of Efficiency	Percent of Efficiency	Percent of Efficiency
2,000	98.7	99.4	100.0
5,000	92.5	98.5	100.0
7,000	—	—	100.0
8,000	87.3	97.6	99.9
10,000	84.0	97.0	—
12,000	—	—	98.6

CAPACITY OF COMPRESSORS

9-3. On a typical job, some tools operate almost continuously, while others operate infrequently. An analysis should be made to determine the probable *actual need* before determining the compressor requirements. If ten rock drills are nominally drilling, generally no more than five or six of the drills will be consuming air at a given time. Additionally, the amount of air used will vary considerably in different applications. *Table 9-2* provides data on the air requirements of specific tools. After considering the number of working tools and their air requirements, increase the total amount of air demanded by 10 percent to compensate for leakage.

Table 9-2. Description and Operating Data for Pneumatic Tools

Tool	Air Requirements		Hourly Work Output	Air-Line Hose Diameter
	psi	cfm		
Paving breaker (jackhammer) (80-lb) Attachments: chisel point,moil point, 8" diameter tamper, sheeting driver	80-100	65	15 sq ft of 6" asphalt paving with chisel point; 12 to 50 sq ft of 6" to 8" nonreinforced concrete withmoil point depending upon width of cut (12 sq ft for narrow cut, 50 sq ft for wide cut); maximum lift of 8" with tamper; driving wood or up to 2" thick steel sheeting with sheeting driver	3/4"
Paving breaker (clay digger) (25-lb) Attachments:moil point, pick, spade, drum opening tool	80-90	35	Loosen 1.2 cubic yards of tough clay with spade; open 20 to 30, 55-gallon drums with a drum-ripping tool	1/2"
Nail driver Attachments: 1/2" and 3/4" head driving sets, rivet buster	90	30	250, 80d nails (after the nails have been started with a hammer or a sledge)	1/2"
Circular saw Attachments: woodworking, 12" blade (Special abrasive disks available for cutting other materials.)	80-100	75	Cuts 4" x 4" lumber in 30 seconds	1/2"
Chain saw Attachments: 24" blade, Type I, Size 1	80-100	90	Cuts 12" diameter hardwood log in 50 seconds. (Under 25': 5/8", 25' to 100': 3/4", over 100': 1")	5/8" to 1/2"
Wood drill Attachments: 2" diameter capacity. Ship augers range from 7/16" to 2" in 1' and 3' lengths.	80-100	60	Using largest size auger, 125 holes 36" deep	3/4"
Sump pump (3" discharge, 175-GPM capacity)	80-90	100	175 GPM at 25' head 150 GPM at 150' head	3/4"
Steel drill (Number 3 Morse taper chuck, 1 1/4" capacity)	90-100	27	30 each 1" diameter holes in 1" thick steel plate (lead holes of 1/4" diameter drilled previously)	1/2"
Handheld rock drill (dry-type, 55-lb) Attachments: 2', 4', 6', and 8' hollow-steel drill rods and 1 5/8", 1 3/4", 1 7/8", and 2" drill bits	80-100	95	Soft rock: 1 3/4" Hole 15-20' Medium rock: 10-15' Hard rock: 5-10'	3/4"

NUMBER OF COMPRESSORS

9-4. The number of compressors required will depend on the sizes available. Normally, if 1,400 cfm of free air were required for a specific job, two 750-cfm units would be sufficient. Air compressors are sturdy machines, but like all mechanical equipment they require maintenance. Therefore, in some cases a standby unit will be required.

LOCATION OF COMPRESSORS

9-5. If possible, centrally locate all compressors on the job. This arrangement has the advantage of unified operation and better supervision. It is possible that a central location is not advisable due to a lack of piping, too large a friction loss, or obstructions on the job site. In this case, it would be necessary to locate compressors at appropriate points. All air compressors must be leveled and should be placed as close to the air-operated devices as conditions will permit.

OPERATION OF COMPRESSORS

9-6. Air compressors should always be located upwind from the work to keep foreign material out of the air intake. When operating under extremely dusty conditions, take precautions to protect the units from as much dust as possible. Other factors to consider are as follows:

- Open all drain cocks to drain condensation after each 8 hours of operation, thus eliminating the possibility of rusting or freezing.
- Close the side panels of the compressor housing when it is being operated in cold weather.
- Block the wheels and engage the hand brake of the trailer mount before operation.
- Ensure that the receiver tank is drained of air when operations are complete.

COMPRESSED-AIR USES

9-7. Compressed air is used extensively on construction projects. In many instances, compressed air is the most convenient method of operating equipment and tools.

ASPHALT PLANTS

9-8. Air compressors are frequently used in asphalt plants for fuel atomization of the dryer burner. Compressors are also used to clean up the plant, to power various tools at the paving site, and to dedrum.

CONCRETE OPERATIONS

9-9. At the batch plant, vibrators may be used on the aggregate hopper to prevent bridging. Air-driven pin drivers and cleaning devices for cleaning sawed joints are used at the paving site.

PNEUMATIC TOOLS

9-10. The military uses pneumatic paving breakers, nail drivers, saws, drills, pumps, and a variety of other pneumatic tools. Pneumatic tools can be powered by either a reciprocating-percussion or a rotary-vane air motor.

- **Reciprocating-percussion air motor.** The reciprocating-percussion air motor is used when a hammering action is desired. It employs a free-floating piston moving in a cylinder. When the throttle is opened, a set of valves introduce air alternately to the ends of the cylinder, driving the piston back and forth. The force of the piston is transmitted to the tool, which does the work.
- **Rotary-vane air motor.** The rotary-vane air motor is employed when a rotary motion is desired. The motor employs a cylinder having an eccentrically mounted slotted rotor, with each slot containing a spring-loaded vane. When the throttle is opened, compressed air enters a small compartment. Pressure on the vanes causes the rotor to turn in the direction of a larger compartment. A gear train transmits the rotation to the attachment, which does the work.

9-11. Two important factors that affect the condition of a pneumatic tool are lubrication and air pressure.

- **Lubrication.** To check for proper lubrication of a pneumatic tool, pass a piece of paper in front of the tool exhaust port. If a thin film of oil accumulates on the paper, the tool is being properly lubricated. If drops of oil appear on the paper or if oil foams around the exhaust port, the tool is over-lubricated. If no oil appears, the lubrication device should be checked immediately.
- **Air pressure.** Each tool requires a specified volume of air at a specific pressure. If the volume of air or pressure is allowed to drop excessively, considerable damage will result. Check for air leaks in the hose and around the air connections. Listen to and observe the tool when it is operating. If a tool appears to be operating sluggishly or appears to be surging (erratic operation), it has either too much or too little pressure. The tools should never be operated with less than 70- or more than 100-psi pressure at the tool. If the air-pressure gauge on the air compressor continually remains below 70 psi, the unit is overloaded (too little pressure at the tool).

9-12. Most pneumatic tools are heavy and create a considerable amount of vibration. A difficulty sometimes encountered with their use is operator fatigue. This is a particular problem with inexperienced operators. Careful attention should be given to the selection of operators to ensure that they are in good physical condition and strong enough to operate the equipment.

AIR MANIFOLDS

9-13. Many construction jobs require more compressed air per minute than any one compressor will produce. An air manifold is a large-diameter pipe used to transport compressed air from one or more air compressors without a detrimental friction-line loss.

CONSTRUCTION

9-14. Manifolds can be constructed of any durable pipe. Compressors are connected to the manifold with flexible hoses. A one-way check valve must be installed between the compressor and the manifold. This valve keeps the manifolds back pressure from possibly forcing air back into a compressor's receiver tank. The compressors that are grouped to supply an air manifold may be of different capacities, but the final discharge pressure of each should be coordinated at 100 psi. Compressors of different types should not be used on the same air manifold. The difference in the pressure control systems of a rotary and a reciprocating compressor could cause one compressor to become overloaded while the other compressor idles. The Army commonly constructs air manifolds of 6-inch-diameter *invasion* piping. Air may be used at any point along the manifold by installing outlet valves for connecting air lines and pneumatic tools.

COMPRESSED-AIR DISTRIBUTION SYSTEM

9-15. The purpose of installing a compressed-air distribution system is to provide a sufficient volume of air to the work site at pressures adequate for efficient tool operation. Any drop in pressure between the compressor and the point of use is an irretrievable loss. Therefore, the distribution system is one

of the most important elements of the total system. Observe the following general rules in planning a compressed-air distribution system:

- Pipe sizes should be large enough so that the pressure drop between the compressor and point of use does not exceed 10 percent of the initial pressure.
- Each header or main line should be provided with outlets as close as possible to the point of use. This permits shorter hose lengths and avoids large pressure drops through the hose.
- Condensate drains should be located at appropriate places along the headers or main lines.

FRICITION LOSSES

9-16. The hose or pipe connecting the tool to the air compressor resists the flow of air. Consequently, the pressure at the tool end of the line is less than at the compressor end. The air-line friction increases as the diameter of the hose or pipe decreases or as the length of the hose or pipe increases. Through practice, it has been determined that a 200-foot-long, 3/4-inch-diameter hose is the maximum length and diameter to which a handheld tool can be connected and operated efficiently. Standard tables (*Tables 9-3 and 9-4*) are available for calculating the friction loss in a pipe or hose.

AIR-LINE HOSE

9-17. Air-line hose is a rubber-covered, pressure-type hose used for transmitting compressed air. Hose with a 3/4-inch inside diameter is used with hand-operated tools and hose with a 2-inch inside diameter is used with a crawler-mounted drill. Hose is usually furnished in 50-foot lengths and equipped with quick-acting fittings (for attaching a tool, a compressor, or another hose). Leader hose is made of oil-resistant neoprene rubber and has end attachments. It is used between the air-line oiler and an air tool. Sections of leader hose are usually 12 or 25 feet long and 1/2 or 3/4 inch in diameter.

AIR-LINE OILER

9-18. The air-line oiler is a reservoir which is placed in the air line directly in front of the air tool for the purpose of lubricating the tool. As the air passes through the oiler, it picks up the oil which is carried into the tool. An adjustable needle controls the amount of oil entering the air stream. There are both directional and nondirectional oilers. The arrow should be pointed in the direction of the airflow when it is connected to the air line.

PNEUMATIC TOOLS

9-19. Pneumatic tools are simpler in design than similar gasoline or electric-powered tools and require less maintenance. A pneumatic tool with nonsparking attachments can be operated around petroleum products or explosive materials without presenting a fire hazard.

Table 9-3. Loss of Air Pressure Due to Friction in a Pipe¹
 (in psi per 1,000 Feet of Pipe With 100-Pound-Gauge Initial Pressure)

Cubic Feet of Free Air Per Minute	Nominal Pipe Diameter (Inches)								
	1	1 1/4	1 1/2	2	2 1/2	3	3 1/2	4	4 1/2
100	27.9	6.47	2.86	0.77	0.30	—	—	—	—
125	48.6	10.20	4.49	1.19	0.46	—	—	—	—
150	62.8	14.60	6.43	1.72	0.66	0.21	—	—	—
175	—	19.80	8.72	2.36	0.91	0.28	—	—	—
200	—	25.90	11.40	3.06	1.19	0.37	0.17	—	—
250	—	40.40	17.90	4.78	1.85	0.58	0.27	—	—
300	—	58.20	25.80	6.85	2.67	0.84	0.39	0.20	—
350	—	—	35.10	9.36	3.64	1.14	0.53	0.27	—
400	—	—	45.80	12.10	4.75	1.50	0.69	0.35	0.19
450	—	—	58.00	15.40	5.98	1.89	0.88	0.46	0.25
500	—	—	71.60	19.20	7.42	2.34	1.09	0.55	0.30
600	—	—	—	27.60	10.70	3.36	1.56	0.79	0.44
700	—	—	—	37.70	14.50	4.55	2.13	1.09	0.59
800	—	—	—	49.00	19.00	5.89	2.77	1.42	0.78
900	—	—	—	62.30	24.10	7.60	3.51	1.80	0.99
1,000	—	—	—	76.90	29.80	9.30	4.35	2.21	1.22
1,500	—	—	—	—	67.00	21.00	9.80	4.90	2.73

¹Compressed Air Handbook, Compressed Air and Gas Institute, 1947.

Table 9-4. Loss of Air Pressure Due to Friction in a Hose¹
 (in psi per 50 Feet of Hose With 100-Pound-Gauge Initial Pressure)

Cubic Feet of Free Air Per Minute	Nominal Hose Diameter (Inches)				
	1/2	3/4	1	1 1/4	1 1/2
20	0.6	0.2	—	—	—
30	2.0	0.4	0.1	—	—
40	4.3	0.6	0.2	—	—
50	7.6	1.0	0.2	—	—
60	12.0	1.4	0.4	—	—
70	17.6	2.0	0.5	0.1	—
80	24.6	2.7	0.6	0.2	—
90	33.3	3.5	0.8	0.2	—
100	44.5	4.4	1.0	0.3	—
110	—	5.4	1.2	0.4	—
120	—	6.6	1.5	0.4	0.1
130	—	7.9	1.8	0.5	0.2
140	—	9.4	2.1	0.6	0.2
150	—	11.1	2.4	0.7	0.2

¹Compressed Air Handbook, Compressed Air and Gas Institute, 1947.

PAVING BREAKER (JACKHAMMER) (80-POUND)

9-20. The pneumatic paving breaker (80-pound weight class) (*Figure 9-3*) is used for heavy-duty demolition work on concrete, brick, asphalt, and macadam. It is also used for demolishing walls, columns, piers, and foundations and for general rock breaking. A variety of attachments may be used with this tool, depending on the type of work. This tool is a member of the reciprocating percussion family of air tools. It weighs 87.5 pounds, uses a 3/4-inch-diameter hose, and requires 65 cfm of air at 80 to 100 psi. It is constructed so that it may be separated into three major groups of parts: the back head, the cylinder, and the front head. The back-head group contains the air controls, the oil reservoir, and the handle. The cylinder group consists of the cylinder, the piston, and the automatic valve assembly. The front-head group provides the means for holding the tool steel or any attachment.

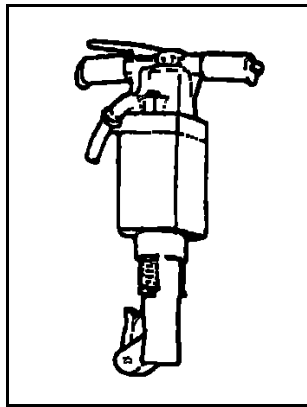

Figure 9-3. Paving Breaker (80-Pound)

Attachments

9-21. Four primary attachments are issued with this paving breaker. They are the moil point, the chisel point, the tamper, and the sheeting driver.

- The moil point is a 20-inch-long piece of 1 1/4-inch-diameter hexagonal tool steel that is pointed at one end and has a retainer collar 6 inches from the opposite end. It is used to break through concrete, stone, or other material having a similar high-abrasive and high-density character.
- The chisel point is similar to the moil point except that it has a 3-inch-wide working edge that is used to cut macadam, frozen ground, or extremely hard earth. It can be used for making a marking line to serve as a guide when cutting concrete.
- The tamper is a 5- to 7-inch-diameter steel pad, mounted on a 1 1/4-inch-diameter hexagonal tool steel. It is used to compact loose material.
- The sheeting driver is made of two steel angles and an impact pad that transmits the blow to the wood or metal sheeting that is being driven.

Production

9-22. Since job-site conditions and the mechanical condition of the air compressors and the pneumatic tools vary on each project, it is not possible to predict the work output of pneumatic tools on all jobs. In nonreinforced, 6- to 8-inch-deep concrete using a moil point, the average work output will range from 50 square feet per hour in large areas to 12 square feet per hour in narrow cuts. In reinforced concrete, production may drop to 50 square feet per 8-hour shift.

Operation

9-23. Hold down the paving breaker while it is in operation, but use only sufficient pressure to guide the tool and keep it in place. Leaning heavily on the paving breaker will shorten the stroke of the tool attachment and result in less work output. Breakers can best be operated in tandem. Only small bites (4 to 8 inches behind the working face) should be taken when breaking hard materials. If a moil point becomes stuck, use a second breaker to break the material binding the point. If the point becomes stuck when using a single breaker, take the paving breaker off and use another point to break the stuck point free. Other important operating precautions are as follows:

- Wear double hearing protection.
- Wear goggles to protect eyes from chips and dust.
- Ensure that the shank of each attachment is the correct size. Improper shank sizes will reduce the effectiveness of the blow and will cause damage to the paving breaker.
- Keep the points of the attachments sharp.
- Keep all nuts tight. The air hose to the paving-breaker connections should be checked frequently to ensure that no air is escaping.
- Provide a clear work area for efficient tool operation.

Maintenance

9-24. Maintenance problems inherent with the paving breaker are caused by improper use of the attachments. Too often, attempts are made to drill holes with the moil point. The moil point is a breaking device. Attempting to drill holes with it will break the point. The chisel point is designed for cutting asphalt and soft materials. If it is used for breaking concrete, the point will be damaged beyond repair. A frequent source of trouble with the paving breaker is breakage of the tool-latch retainer bolt. The cause of this is the operator not shutting off the tool when the moil point breaks through the material. The front head bounces on the concrete and causes the retainer bolt to break.

PAVING BREAKER (CLAY DIGGER) (25-POUND)

9-25. The pneumatic paving breaker (25-pound weight class) (*Figure 9-4, page 9-10*) is a medium-weight tool made for spading, trimming, cutting, or picking clay, hardpan, or frozen ground. It weighs 25.2 pounds, uses a 1/2-inch-diameter hose, and requires 35 cfm of air at 80 to 90 psi. It is constructed so that it may be separated into three major groups of parts: the back head, the cylinder, and the front head. The back-head group includes the handle. The cylinder group constitutes the main body of the tool. It includes the hammer,

which is driven against the shank of the tool by the air pressure. The front-head group is the tool retainer.

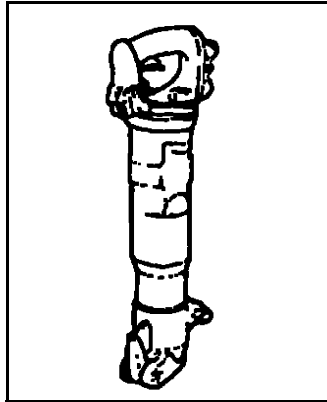

Figure 9-4. Paving Breaker (25-Pound)

Attachments

9-26. The three primary attachments normally issued with this breaker are the moil point, the pick, and the spade. A metal, drum-ripping tool may be issued for opening 55-gallon drums.

9-27. The moil point consists of a 15-inch straight length of 1-inch-diameter tool steel that is pointed on one end. It is used as a light demolition tool on masonry, concrete, or other dense material.

9-28. The pick's blade is 3 inches wide by 8 inches long with a pointed cutting end. It is used for digging into frozen ground, cemented gravel, or other materials too hard to be penetrated by the spade.

9-29. The spade (shaped like a garden spade) is 5 1/2-inches wide by 8-inches long. It is used for digging trenches, preparing footings or foundations, digging caissons, driving tunnels, or doing any general digging that is too difficult and slow for an ordinary hand spade.

9-30. The metal, drum-ripping tool has a 1-inch-wide cutting blade, topped by a 5/8-inch-thick, extended snubnose. The Army has the following two types—

- Type I is used to cut heads from metal drums. The nose of this ripping tool is curved to allow it to easily follow the curvature of the head on the drum.
- Type II is used to split metal drums lengthwise. It has a straight nose and is capable of opening 20 to 30, 55-gallon drums per hour.

Production

9-31. The attachment used most frequently with the 25-pound breaker is the clay spade. About 12 cubic yards of tough clay can be loosened per 10-hour shift.

Operation

9-32. Operators should merely guide the tool, never ride or lean on it. The tool is designed for trimming or digging, not for prying.

Maintenance

9-33. Give particular attention to the tool's retainer assembly. Dirt and other abrasive materials will enter the bottom of the retainer and cause excessive wear. This wear can be prevented if the tool is not allowed to penetrate past the wide portion of the clay spade.

NAIL DRIVER

9-34. The pneumatic nail driver (*Figure 9-5*) is a long-stroke, piston-action riveting hammer. The nail driver is designed for driving heavy drift pins and spikes. It weighs 24 pounds, uses a 1/2-inch-diameter hose, and requires 30 cfm of air at 90 psi. The handle is formed to fit the hand, with a thumb-operated throttle lever that controls the admission of air. The barrel of the driver houses the valve mechanism, the piston, and the nail set. A sleeve on the end of the nail set prevents the tool from sliding off the head of the nail. A safety set retainer screws onto the nozzle end of the barrel and holds the nail set in the tool at all times.

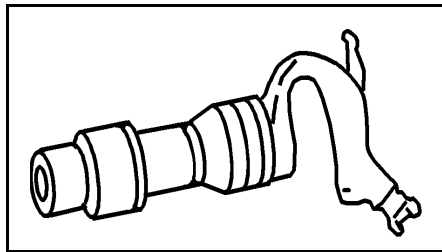

Figure 9-5. Nail Driver

Attachments

9-35. The nail driver is issued with 1/2- and 3/4-inch nail sets and a rivet buster.

Production

9-36. Used as a nail driver, 250 60-penny nails can be driven per hour (after the nails have been started by hand).

Operation

9-37. Always start the nails or spikes with a handheld hammer. The nail driver must be in line with the nail or spike being driven and should strike the nail or spike squarely to minimize the possibility of bending.

Maintenance

9-38. The retainer housing on a nail driver often breaks because the operator fails to keep the nail set against the work. Any attempt to countersink a nail will result in a broken retainer spring.

CIRCULAR SAW

9-39. The pneumatic circular saw (*Figure 9-6*) may be used for ripping and crosscut tasks. It weighs 32 1/2 pounds, uses a 1/2-inch-diameter hose, and requires 75 cfm of air at 80 to 100 psi. The handle assembly includes a D-shaped handle with a trigger-type throttle and a thumb-operated plunger lock. The body contains a rotary-vane air motor with a flyball governor that limits the motor speed to 2,400 rpm. A fixed blade guard is attached to the left side of the body to protect the operator. The top handle (above the body) is used to control and guide the saw. The foot is hinged to the front of the upper blade guard through a sector. By loosening a wing nut on this sector, the foot can be tilted for bevel cuts up to 45°. At the back of the foot a second sector, secured by a wing nut, permits adjustment of the depth of cut from 2 3/8 to 6 inches. Two V-shaped notches on the front of the foot simplify cutting along a line. The deeper V-notch is in line with the blade for right-angle cuts, while the smaller V-notch is in line with the blade for 45° bevel cuts. A rip fence (attached to the front of the foot by means of a wing screw) should be used for ripping when long cuts must be made. A telescopic blade guard covers the lower portion of the blade when the saw is not being used. This guard is spring-loaded so it closes automatically when the blade is lifted from the cut, but folds into the fixed blade guard when the saw is being operated.

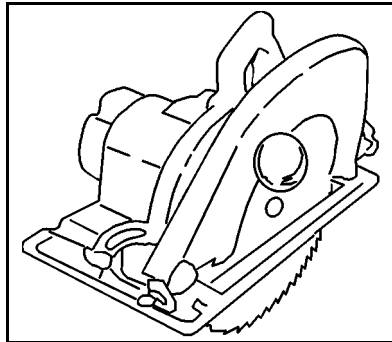

Figure 9-6. Circular Saw

Attachments

9-40. This saw is issued with a 12-inch combination blade used for ripping and crosscutting in wood only. When equipped with the proper abrasive disk, the pneumatic saw can be used to cut brick, stone, concrete, tile, asbestos cement sheets, steel, or cast iron. No one type of abrasive disk or saw blade is suited for all materials. Order these items carefully for each specific kind of work.

Production

9-41. Using the combination blade for crosscutting, the saw will cut a 4- by 4-inch board in 30 seconds. The maximum depth of cut at 90° is 4 3/8 inches.

Operation

9-42. Always use the proper blade for the material being cut. Make sure that the material to be cut is free of nails, spikes, or similar objects. Never jam the saw into a cut. If the saw is to be used upside down for prolonged periods of

time, be careful that the exhaust port does not become clogged. Keep hands away from the blades, and shut off the air when the tool is not in use.

Maintenance

9-43. In many cases, the pneumatic circular saw is inverted and used as a table saw. When this is done, the exhaust port is exposed to the woodcuttings. An accumulation of these cuttings will clog up the air motor and make the saw useless.

CHAIN SAW

9-44. The pneumatic chain saw (*Figure 9-7*) is a heavy-duty saw intended primarily for cutting trees or timbers up to 24 inches in diameter. It weighs 45 pounds and requires 90 cfm of air at 80 to 100 psi. The hose diameter varies with the distance to the air source (25 feet or less from source, 5/8 inch; 26 to 100 feet from source, 3/4 inch; more than 100 feet from source, 1 inch). The head assembly consists of a drive housing, two handles, a guide bracket, a bumper, and an air connection. The drive housing contains a four-vane rotary motor. A guard bar made of heavy steel extends from the head assembly to the idler assembly and is slightly arched so it lies about 3/4 inch from the upper portion of the chain. Its purpose is to protect the operator from injury in the event of a break in the chain. The saw should never be operated without this guard. The guard bar issued with the chain saw is for the 24-inch-length saw; however, guard bars are available through supply channels for the 36- and 48-inch-length saws. Use of a 48-inch bar requires two operators.

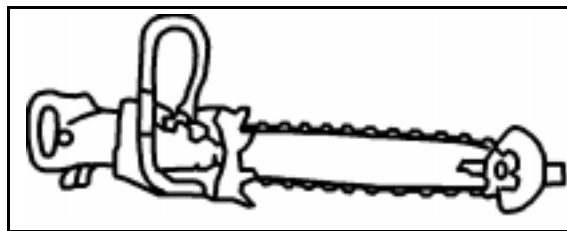

Figure 9-7. Chain Saw

Chains

9-45. The standard chain has a 3/4-inch pitch and a 3/8-inch cut for general-purpose use on any capacity saw. It is used for felling and for cutting hardwood or softwood. It is easy to sharpen and holds its cutting edge for a relatively long time. This chain consists of three-link sets. The link in the center of each set contains a raker tooth. Raker teeth are set alternately in the sets, to the right and left. The first and third links in each set contain a cutter tooth. The cutter teeth alternate on the chain, with the teeth set to the right and to the left. The cutter teeth control the width of the cut. A 76-inch chain is issued with the 24-inch-length chain saw; however, chains of 100 and 124 inches are available through supply channels for use with 36- and 48-inch-length saws.

Production

9-46. The chain saw can cut through a 12-inch hardwood log in 50 seconds. Never force the saw into the wood, but allow it to cut at its own speed. Be careful to ensure that the saw does not twist while cutting.

Maintenance

9-47. Keep the chain at the proper tension and properly sharpened. The blade should be adjusted to maintain a 1/2-inch chain slack when pulled up at the center. More slack than this will allow the chain to jump out of the saw guide, causing the blade to bend or break. If the chain is too tight, it will bend and cause sprocket damage.

WOOD DRILL

9-48. The pneumatic wood drill is a heavy-duty, low-speed tool designed to drive auger-type drill bits. It weighs 27 1/2 pounds, uses a 3/4-inch-diameter hose, and requires 60 cfm of air at 80 to 100 psi. It is used extensively in trestle bridge and other timber construction work where it is necessary to drill holes for bolts and pins. The drill body houses a rotary-vane air motor, a gear train (for reducing the motor speed to a chuck speed of about 800 rpm), and an oil reservoir. A chuck is provided for 1/2-inch-diameter drill-bit shanks and a large Allen-type setscrew holds the shank in place. There are two types of chucks—the Morse-taper and the two-screw. The shaft, on which the chuck is mounted, is drilled so the shank will extend into the base of the grip handle. A slot in the base of this handle provides for insertion of a wedge against the end of the bit to loosen it if it is jammed in the chuck. The air line is attached to the end of the throttle handle.

Attachments

9-49. Auger-type drill bits are issued in 1- and 3-foot lengths and have 7/16-, 3/4-, 1-, and 2-inch diameters.

Production

9-50. The drill will bore 125 36-inch-deep holes in one hour using a 2-inch-diameter auger bit.

Operation

9-51. The rotation of the wood drill can be reversed. Always start the drill slowly until the screw is well set. Hold the drill firmly, but do not force it. Exert enough effort to counteract the tendency of the tool to rotate, and be prepared to resist the torque in case the bit becomes stuck. During boring and withdrawing of the auger, keep it in line with the hole.

Maintenance

9-52. The auger bit frequently becomes stuck in the chuck. Remove it by using the auger ejector. Trying to knock it out with a hammer will result in damage to the chuck and/or the auger.

SUMP PUMP

9-53. The pneumatic sump pump (*Figure 9-8*) is a small-capacity pump. The sump pump weighs 50 pounds, uses a 3/4-inch-diameter hose, and requires 100 cfm of air at 80 to 90 psi. Due to its simple, rugged construction it requires little attention. It can operate while completely submerged when an exhaust line is used. The pump assembly consists of an open-impeller centrifugal pump. A combination bottom plate and inlet strainer cover the pump intake opening, and a 3-inch exhaust connection is mounted on the side of the pump housing.

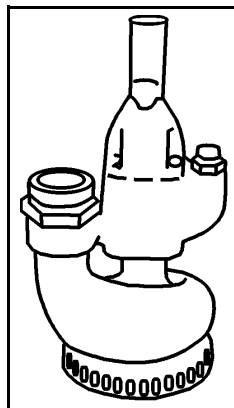

Figure 9-8. Sump Pump

Production

9-54. The pneumatic sump pump may be either a Class 1 (for transferring sewage and sludge) or a Class 2 (for transferring petroleum products). This pump is rated at 175 gallons per minute (GPM) against a 25-foot head or 150 GPM against a 150-foot head.

Operation

9-55. To ensure maximum efficiency, keep the inlet strainer clean and free of debris. Keep the pump away from mud, and clean the strainer as often as is necessary. Keep the exhaust-line outlet above the water level. Use only water-pump grease in the fittings on the pump. Drain the pump of water when not using it.

Maintenance

9-56. If silt and dirt are left in the pump after use, it will cause the impeller to stick and will require disassembly and cleaning before it can be used again. Allowing water to get into the pump through the exhaust port will cause failure of the grease seals.

STEEL DRILL

9-57. The pneumatic steel drill is a portable tool for drilling, reaming, and tapping in metals. The drill weighs 27.5 pounds, uses a 1/2-inch-diameter hose, and requires 27 cfm of air at 90 to 100 psi. The chuck speed is 425 rpm. It is suitable for 1 1/4-inch drilling and 1-inch reaming or tapping.

Attachments

9-58. Bits for use with this drill are 1/2-inch in diameter with a Number 3 Morse-taper shank.

Production

9-59. Used as a drill, thirty 1-inch holes can be drilled per hour if the steel plate has been prepared beforehand with 1/4-inch lead holes.

Operation

9-60. The rotation of the steel drill cannot be reversed. It is important to ensure that the bits have clean, sharp edges, and that they are not chipped or damaged in any way.

- Use cutting oil to cool and lubricate the drill bit.
- Use a center punch to mark the center and to hold the tip of the drill in place when starting a hole.
- Do not use worn chucks.
- Wear goggles to protect eyes from steel chips or shavings.
- Clamp all material that is being drilled to a bench. This will prevent injuries to personnel if the drill should bind in the material.

Maintenance

9-61. The bit will be damaged due to heat if cutting oil is not used. Too much pressure applied to the bit will stall the drill and cause undue wear on the gear assembly. This can damage the feed-screw system.

HANDHELD ROCK DRILL

9-62. The pneumatic handheld rock drill is a piston-action unit with independent air-motor rotation. It is designed primarily as a hard-rock drill; however, it is also efficient in soft and medium formations. It weighs 57 pounds, uses a 3/4-inch-diameter hose, and requires 95 cfm of air at 80 to 100 psi. The drill consists of a back-head group, a cylinder unit, and a front-head group. It is designed so that air may be directed through the drill, down the drill steel, and into the bottom of the hole to blow out rock cuttings.

Attachments

9-63. This drill is issued with drill rods in 2-, 4-, 6-, and 8-foot lengths and drill-bits of 1 5/8, 1 3/4, 1 7/8, and 2 inches.

Production

9-64. The drill is designed for vertical drilling. If large numbers of horizontal holes are required, some mechanical means must be devised for holding the drill in place. It will drill holes efficiently to a depth of 10 feet. See *Table 9-2, page 9-3*, for production rates.

Operation

9-65. Bent drill steels should not be used. They cause damage to the drill and usually result in a stuck bit and lost production.

SAFETY

9-66. Be very careful when working with compressed air. At close range it is capable of putting out eyes, bursting eardrums, causing serious skin blisters, or even killing an individual.

AIR COMPRESSORS

- Ensure that the intake air is cool and free from flammable gases or vapors.
- Do not permit wood or other flammable materials to remain in contact with the air-discharge pipe.
- Shut down the compressor immediately if the air discharged from any stage rises unduly or exceeds 400°F.
- Ensure that all the pressure gauges are in good working order.
- Do not kink a hose to stop the air flow.
- Check the safety valves, pressure valves, and regulators to determine if they are working properly before starting the air compressor.
- Do not leave the compressor after starting it, unless you are certain that the control, unloading, and governing devices are working properly.
- Do not run an air compressor faster than the manufacturer's recommended speed.
- Use only the proper grade of oil as recommended by the manufacturer.
- Use only oils which have high flash points to lubricate the air cylinders.
- Avoid the application of too much oil.
- Keep the compressor, the tanks, and the accompanying piping clean to guard against oil-vapor explosion.
- Clean the intake air filters periodically.
- Use only soapy water or a suitable nontoxic, nonflammable solution for cleaning compressor intake filters, cylinders, or air passages. Never use benzene, kerosene, or other light oils to clean these portions of a system. These oils vaporize easily and the vapor will explode when compressed.
- Turn off the motor before making adjustments and repairs.
- Make certain that the compressor is secured and cannot be started automatically or by accident, that the air pressure in the compressor is completely relieved, and that all the valves between the compressor and the receivers are closed before working on or removing any part of the compressor.

PNEUMATIC TOOLS

- Wear protective clothing and equipment (such as goggles, gloves, and respirators) appropriate for the particular pneumatic tool being operated.
- Maintain a firm grip on the tool at all times.
- Maintain a good footing and proper balance at all times while operating pneumatic tools.

- Release the throttle of the tool at the first indication that the tool is out of control. Release the tool and let it fall if it cannot be controlled.
- Turn off the air and disconnect the tool when repairs or adjustments are being made or the tool is not in use. When disconnecting the tool, all pressurized air should be discharged from the line before the connection is broken.
- Inspect the hose to ensure that it is in good condition and free from obstructions before connecting a pneumatic tool. When blowing out the line, make certain the end of the hose is pointed into the air and is secured against whipping. Make certain all connections are tight before the line is pressurized.
- Lay down pneumatic tools in such a manner that no harm can be done if the switch is accidentally tripped. Do not leave an idle tool in a *standing* position.
- Keep pneumatic tools in good operating condition and thoroughly inspect them at regular intervals. Give particular attention to the control and exhaust valves, the hose connections, the guide clips on hammers, and the chucks of reamers and drills.
- Shut off the tool and relieve the pressure from the line before disconnecting the tool from the line.
- Remove leaking or defective hoses from service. The air hose must be suitable to withstand the pressure required for the tool.
- Do not lay the hose over ladders, steps, or walkways in such a manner as to create a tripping hazard.
- Where a hose is run through a doorway, protect the hose against damage from the door's edge.
- Do not lay the hose between the operator's legs while the tool is being operated.
- Never point an air hose at other personnel. Do not use compressed air to clean clothing being worn or to blow dust off the body.

Handheld Rock Drills

- Do not (under any circumstances) wear loose or torn clothing.
- Examine the drill for defects. Pay particular attention to bit flutes, which must be ground to uniform size, sharpness, and length.
- Hold the machine on a straight line with the hole being bored.
- Do not feed the machine too fast.
- Establish a firm footing before starting the operation.
- Do not modify or bypass the handgrip switch. (All drills are equipped with a handgrip switch that will shut off the air supply when the grip is released.)

Paving Breakers

- Wear suitable goggles when operating pneumatic breakers.
- Roughen hard materials or slick surfaces with a sledgehammer to improve breaker control.