

FIELD MANUAL  
NO 10-562  
TECHNICAL ORDER  
NO 13C7-34-1

HEADQUARTERS  
DEPARTMENTS OF THE ARMY  
AND THE AIR FORCE  
Washington, DC, 23 May 1989

**AIRDROP OF SUPPLIES AND EQUIPMENT:  
RIGGING WHOLE BLOOD**

**TABLE OF CONTENTS**

	Paragraph	Page
<b>PREFACE</b> .....		iv
<b>CHAPTER 1 INTRODUCTION</b>		
Description of Items .....	1-1	1-1
Special Considerations .....	1-2	1-1
<b>CHAPTER 2 RIGGING WHOLE BLOOD ON A 16-FOOT, TYPE V AIRDROP PLATFORM</b>		
Section I <b>RIGGING BLOOD FOR LOW-VELOCITY AIRDROP</b>		
Description of Load .....	2-1	2-1
Preparing Platform .....	2-2	2-1
Preparing and Placing Honeycomb Layers .....	2-3	2-2
Preparing Wooden Boxes .....	2-4	2-4
Positioning and Lashing Wooden Boxes .....	2-5	2-7
Packing Blood in Cardboard Containers .....	2-6	2-11
Packing Blood Containers in Wooden Boxes .....	2-7	2-13
Installing Suspension Slings .....	2-8	2-17
Stowing Cargo Parachutes .....	2-9	2-18
Installing Release System .....	2-10	2-20
Installing Extraction System and Emergency Restraint Clevises .....	2-11	2-22
Placing Extraction Parachute .....	2-12	2-22
Marking Rigged Load .....	2-13	2-23
Equipment Required .....	2-14	2-24
Section II <b>RIGGING BLOOD FOR LAPE AIRDROP</b>		
Description of Load .....	2-15	2-26
Preparing Platform .....	2-16	2-26
Preparing and Placing Honeycomb Layers .....	2-17	2-27
Preparing Wooden Boxes .....	2-18	2-27

**DISTRIBUTION RESTRICTION.** Distribution authorized to US government agencies only to protect technical or operational information from automatic dissemination under the International Exchange Program or by other means. This determination was made on 4 February 1987. Other requests for this document will be referred to Commandant, US Army Quartermaster Center and School (Provisional), ATTN: ATSM-DTP, Fort Lee, Virginia 23801-5036.

**DESTRUCTION NOTICE.** Destroy by any method that will prevent disclosure of contents or reconstruction of the document.

\*This publication supersedes FM 10-562/TO 13C7-34-1, 28 February 1974.

	Paragraph	Page
Positioning and Lashing Wooden Boxes .....	2-19	2-27
Packing Blood in Cardboard Containers .....	2-20	2-32
Packing Blood Containers in Wooden Boxes .....	2-21	2-32
Installing Attitude Control Bar .....	2-22	2-34
Installing Extraction System .....	2-23	2-37
Placing Extraction Parachutes .....	2-24	2-38
Marking Rigged Load .....	2-25	2-39
Equipment Required .....	2-26	2-40

**CHAPTER 3 RIGGING WHOLE BLOOD ON A 24-FOOT, TYPE V AIRDROP PLATFORM FOR LAPE AIRDROP**

Description of Load .....	3-1	3-1
Preparing Platform .....	3-2	3-1
Preparing and Placing Honeycomb Layers .....	3-3	3-2
Preparing Wooden Boxes .....	3-4	3-4
Positioning and Lashing Wooden Boxes .....	3-5	3-4
Packing Blood in Cardboard Containers .....	3-6	3-11
Packing Blood Containers in Wooden Boxes .....	3-7	3-11
Installing Attitude Control Bar .....	3-8	3-14
Installing Extraction System .....	3-9	3-17
Placing Extraction Parachutes .....	3-10	3-17
Marking Rigged Load .....	3-11	3-19
Equipment Required .....	3-12	3-20

**CHAPTER 4 RIGGING WHOLE BLOOD ON A 32-FOOT, TYPE V AIRDROP PLATFORM FOR LAPE AIRDROP**

Description of Load .....	4-1	4-1
Preparing Platform .....	4-2	4-1
Preparing and Placing Honeycomb Layers .....	4-3	4-2
Preparing Wooden Boxes .....	4-4	4-2
Positioning and Lashing Wooden Boxes .....	4-5	4-4
Packing Blood in Cardboard Containers .....	4-6	4-13
Packing Blood Containers in Wooden Boxes .....	4-7	4-13
Installing Attitude Control Bar .....	4-8	4-16
Installing Extraction System .....	4-9	4-19
Placing Extraction Parachutes .....	4-10	4-21
Marking Rigged Load .....	4-11	4-21
Equipment Required .....	4-12	4-22

**CHAPTER 5 RIGGING WHOLE BLOOD IN A-7A, A-21, AND A-22 CONTAINERS FOR LOW-VELOCITY AIRDROP**

Section I

**RIGGING ONE BLOOD CONTAINER IN AN A-7A OR A-21 CONTAINER FOR DOOR DROP**

Description of Load .....	5-1	5-1
Packing Blood in Cardboard Container .....	5-2	5-1
Rigging Load .....	5-3	5-1
Stowing Cargo Parachutes .....	5-4	5-1
Marking Rigged Load .....	5-5	5-5
Equipment Required .....	5-6	5-5

	Paragraph	Page
Section II	<b>RIGGING TWO BLOOD CONTAINERS IN AN A-7A OR A-21 CONTAINER FOR DOOR DROP</b>	
	Description of Load .....	5-7 5-6
	Packing Blood in Cardboard Containers .....	5-8 5-6
	Rigging Load .....	5-9 5-6
	Stowing Cargo Parachutes .....	5-10 5-6
	Marking Rigged Load .....	5-11 5-9
	Equipment Required .....	5-12 5-9
Section III	<b>RIGGING FOUR BLOOD CONTAINERS IN AN A-7A OR A-21 CONTAINER FOR DOOR DROP</b>	
	Description of Load .....	5-13 5-10
	Packing Blood in Cardboard Containers .....	5-14 5-10
	Rigging Load .....	5-15 5-10
	Stowing Cargo Parachutes .....	5-16 5-10
	Marking Rigged Load .....	5-17 5-13
	Equipment Required .....	5-18 5-13
Section IV	<b>RIGGING TWELVE BLOOD CONTAINERS IN AN A-22 CONTAINER</b>	
	Description of Load .....	5-19 5-14
	Packing Blood in Cardboard Containers .....	5-20 5-14
	Rigging Load .....	5-21 5-14
	Stowing Cargo Parachutes .....	5-22 5-23
	Marking Rigged Load .....	5-23 5-24
	Equipment Required .....	5-24 5-25
<b>GLOSSARY</b> .....		Glossary-1
<b>REFERENCES</b> .....		References-1

## PREFACE

---

### SCOPE

This manual tells and shows how to prepare and rig whole blood for low-velocity airdrop from the C-130 and C-141 aircraft and for delivery by LAPE airdrop from the C-130 aircraft. This manual is designed for use by all parachute riggers.

### USER INFORMATION

The proponent of this publication is HQ TRADOC. You are encouraged to report any errors or omissions and suggest ways for improving this manual. Army personnel, send your comments on DA Form 2028 (Recommended Changes to Publications and Blank Forms) directly to:

**Commandant  
US Army Quartermaster Center and School (Provisional)  
ATTN: ATSM-DTP  
Fort Lee, Virginia 23801-5036**

Air Force personnel, send your reports on AFTO Form 22 (Technical Order Publication Improvement Report) through:

**Headquarters  
Military Airlift Command (MAC/DOXT)  
Scott AFB, Illinois 62225-5001**

to:

**Commandant  
US Army Quartermaster Center and School (Provisional)  
ATTN: ATSM-DTP  
Fort Lee, Virginia 23801-5036**

Also send information copies of AFTO Form 22 to:

**San Antonio ALC/MMILRA  
Kelly AFB, Texas 78241-5000**



## CHAPTER 1

# INTRODUCTION

### 1-1. Description of Items

The items covered in this manual are packets of whole blood (Figure 1-1). The packets come in various sizes and are of varying weights.

### 1-2. Special Considerations

The special considerations given below must be followed when rigging packets of whole blood.

**a.** Whole blood must be placed in ice and packaged into cardboard containers by medical personnel in the presence of a 95B lab NCO or a medical officer.

**b.** The whole blood containers must be replenished with ice every 48 hours in the presence of a 95B lab NCO or a medical officer.

**c.** Because of the re-icing restrictions, all wooden boxes should be constructed and lashed to the platform before the whole blood containers are transported to the rigging site.

**d.** A copy of this manual must be available to the joint airdrop inspector during the before- and after-loading inspection.

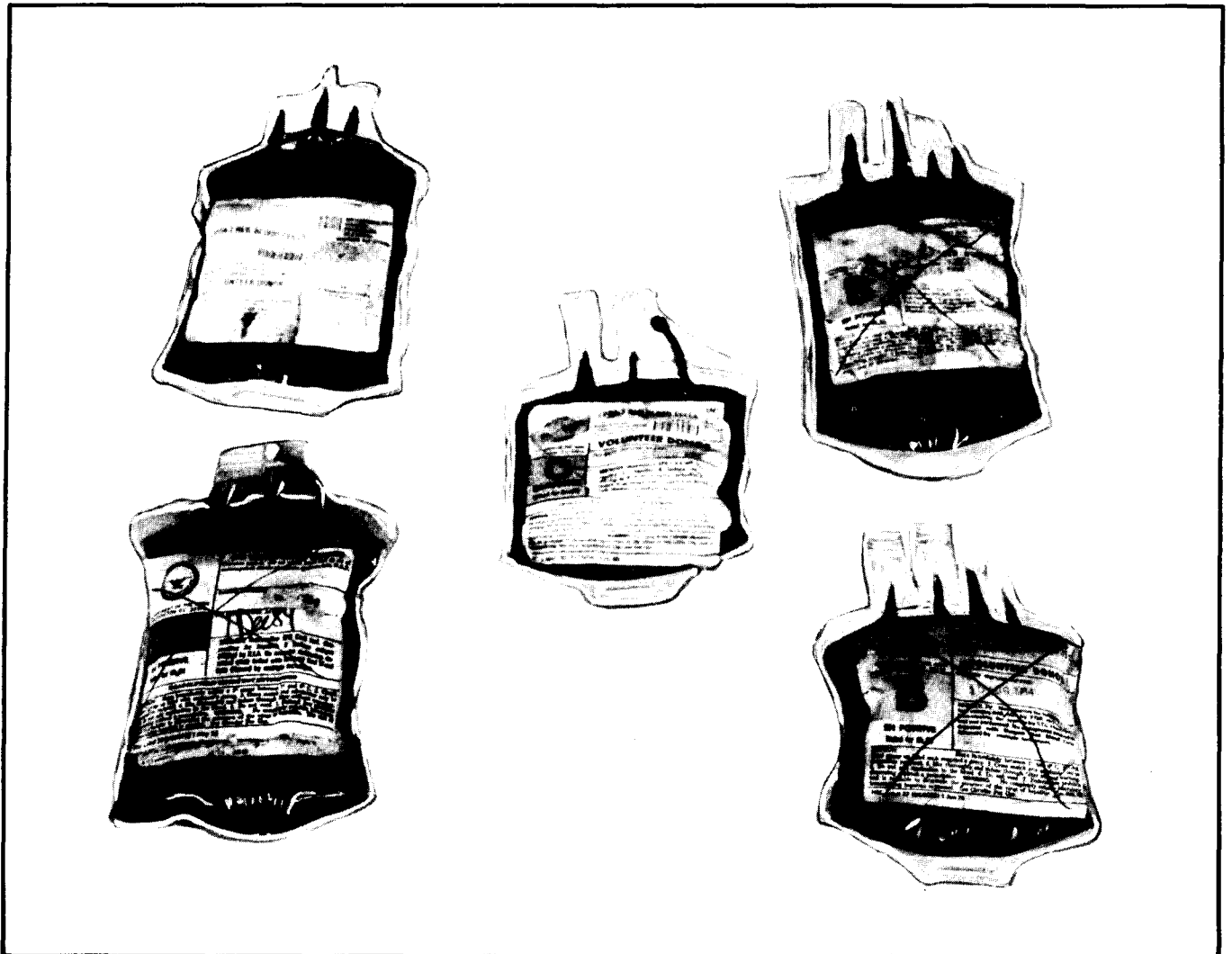

*Figure 1-1. Packets of whole blood*

CHAPTER 2  
RIGGING WHOLE BLOOD ON A 16-FOOT, TYPE V  
AIRDROP PLATFORM

Section I  
RIGGING BLOOD FOR LOW-VELOCITY AIRDROP

### 2-1. Description of Load

Whole blood is rigged on a 16-foot, type V airdrop platform with two G-11A or two G-11B cargo parachutes for C-130 or C-141 aircraft.

### 2-2. Preparing Platform

Prepare a 16-foot, type V airdrop platform as described below.

**a. Assembling and Inspecting Platform.** Inspect, or assemble and inspect, the platform as outlined in TM 10-1670-268-20&P/TO 13C7-52-22.

**b. Installing Tandem Links.** Install a tandem link on the front and rear of each rail as shown in Figure 2-1.

**c. Attaching and Numbering Clevises.** Bolt 44 tiedown clevises to the side rail bushings and tandem links according to TM 10-1670-268-20&P/TO 13C7-52-22 and as shown in Figure 2-1. Number the clevises as shown in Figure 2-1.

#### NOTES:

1. The nose bumper may or may not be installed.

2. Measurements given in this section are from the front edge of the platform, NOT from the front edge of the nose bumper.

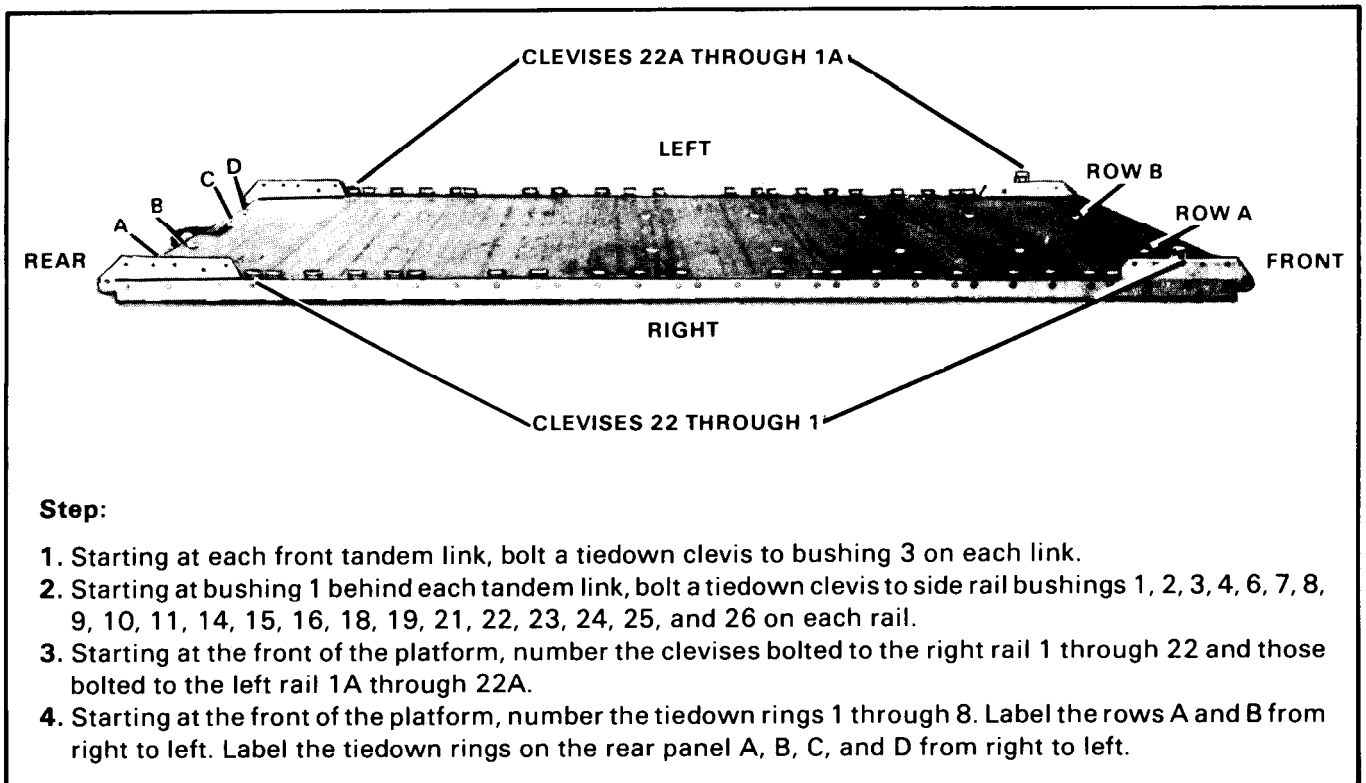
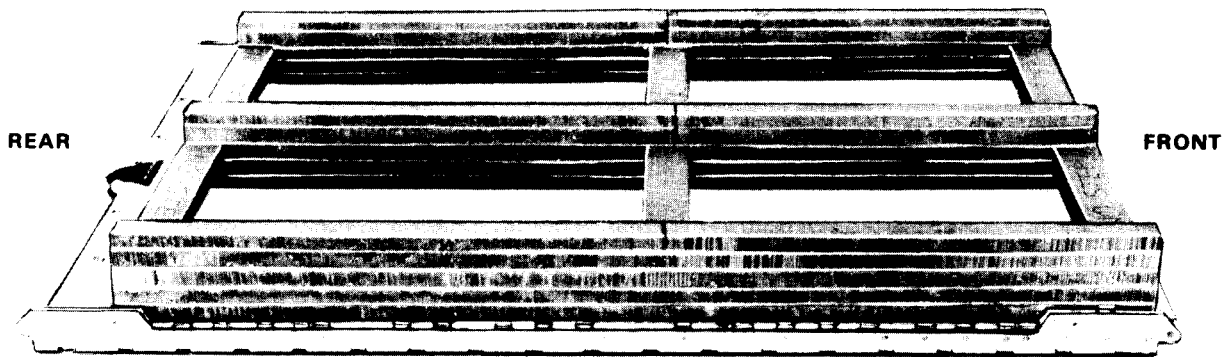

*Figure 2-1. Platform prepared*

### 2-3. Preparing and Placing Honeycomb Layers

Prepare and place the honeycomb layers as shown in Figures 2-2 and 2-3.

**NOTE: Glue all honeycomb layers together. Do not glue the layers to the platform.**



Layer Number	Pieces	Width (Inches)	Length (Inches)	Material	Instructions
1	6	12	90	Honeycomb	Lay two pieces of honeycomb end to end forming a 180-inch row. Prepare two more 180-inch rows. Lay each row 29 3/4 inches apart and 13 inches from the rear edge of the platform. Outside rows are 2 3/4 inches from the side rails.
2	6	10	90	Honeycomb	Center two pieces of honeycomb end to end on top of each row in layer 1.
3	3	91 1/2	8	Honeycomb	Use honeycomb as bridges. Lay one piece across layer 2 flush with front edge of the honeycomb. Lay the second piece across layer 2, 79 1/2 inches from front edge of the honeycomb. Lay the third piece across layer 2 flush with the rear edge of the honeycomb.
	3	8	71 1/2	Honeycomb	Use honeycomb as fillers between the front and middle bridges.
	3	8	84 1/2	Honeycomb	Use honeycomb as fillers between the middle and rear bridges.

Figure 2-2. Honeycomb layers prepared and placed on platform

Layer Number	Pieces	Width (Inches)	Length (Inches)	Material	Instructions
4	6	6	90	Honeycomb	Center two pieces of honeycomb end to end on top of each 180-inch row in layer 3.
5	6	4	90	Honeycomb	Center two pieces of honeycomb end to end on top of each row in layer 4.

Figure 2-2. Honeycomb layers prepared and placed on platform (continued)

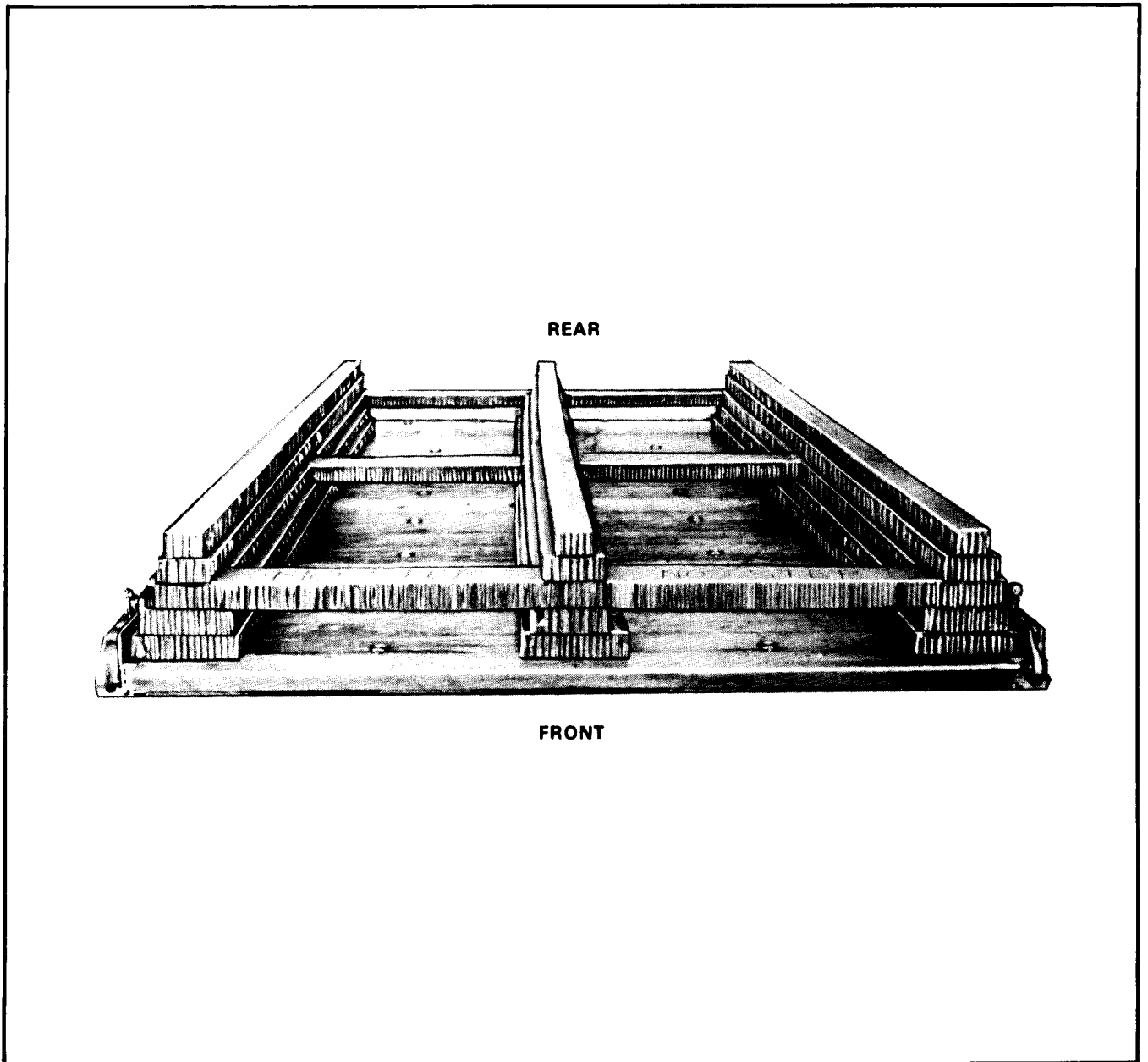
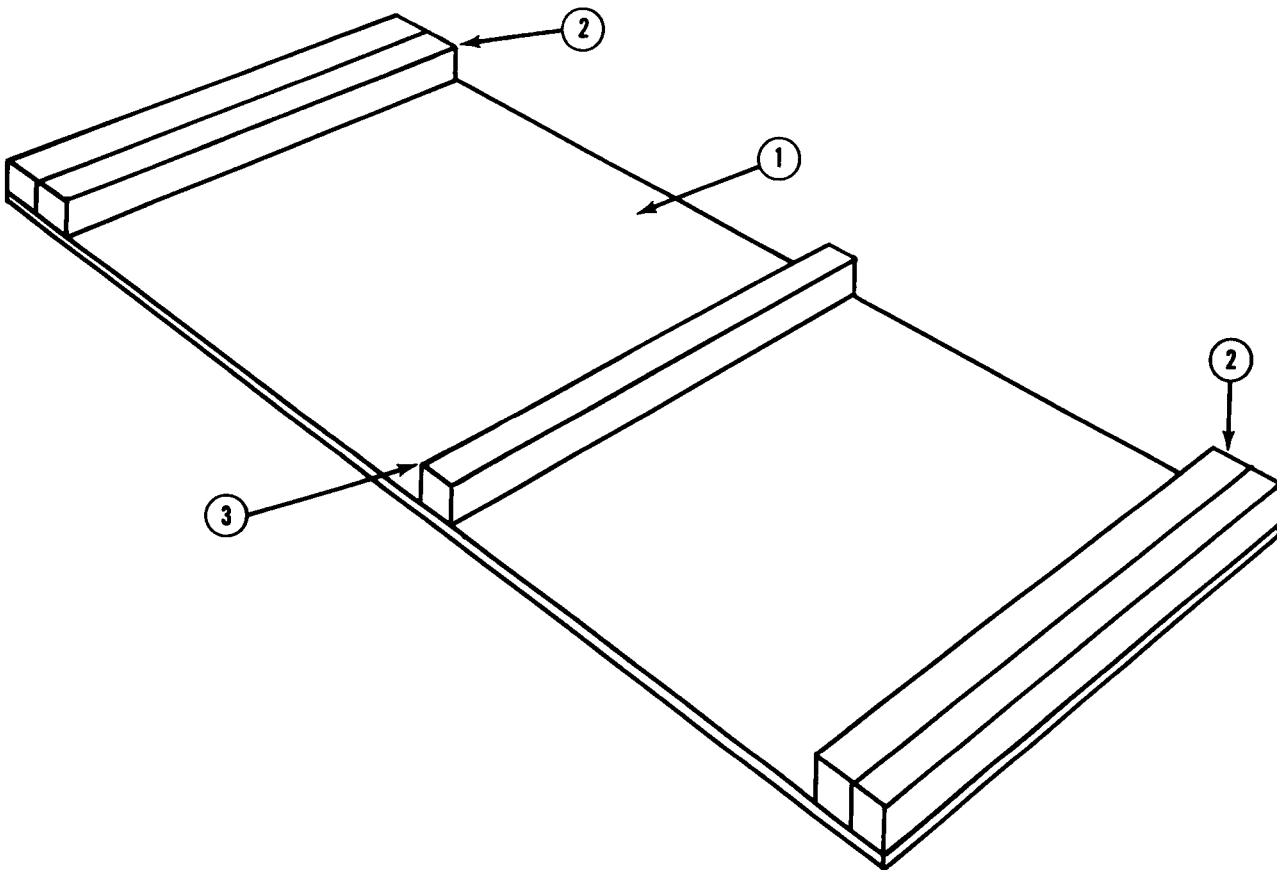

Figure 2-3. Front view of honeycomb layers placed on platform

## 2-4. Preparing Wooden Boxes

Prepare four wooden boxes. An example is shown in Figure 2-4.

1. This drawing is not drawn to scale.
2. Use fourpenny or sixpenny nails.
3. The nails must not enter the inside dimensions of the boxes.
4. Make sure the nails do not penetrate the 4- by 4-inch lumber.



- ① Lay one piece of 3/4- by 43 1/2- by 95 1/2-inch plywood on a flat surface to form a base.
- ② Nail two pieces of 4- by 4- by 43 1/2-inch lumber to each end of the base.
- ③ Nail one piece of 4- by 4- by 43 1/2-inch lumber in the center of the base.

Figure 2-4. Wooden box prepared

**NOTE:** These drawings are not drawn to scale.

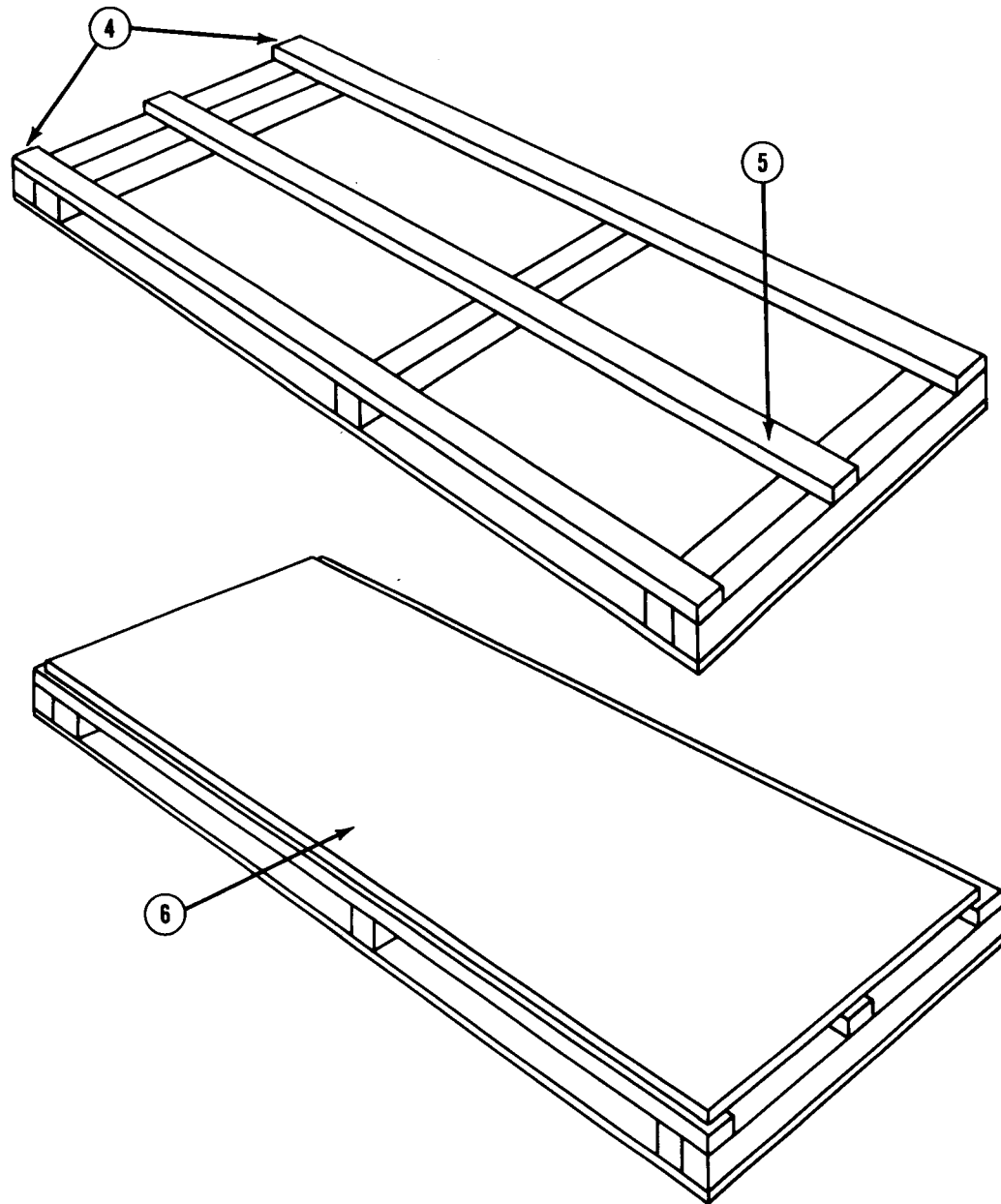

- ④ Nail one piece of 2- by 4- by 95 1/2-inch lumber on top of the 4- by 4- by 43 1/2-inch lumber and flush with each 95 1/2-inch side of the base.
- ⑤ Nail one piece of 2- by 4- by 95 1/2-inch lumber centered between the lumber installed in step 4 above.
- ⑥ Center one piece of 3/4- by 42- by 94-inch plywood on top of the 2- by 4-inch lumber. Nail it in place.

*Figure 2-4. Wooden box prepared (continued)*

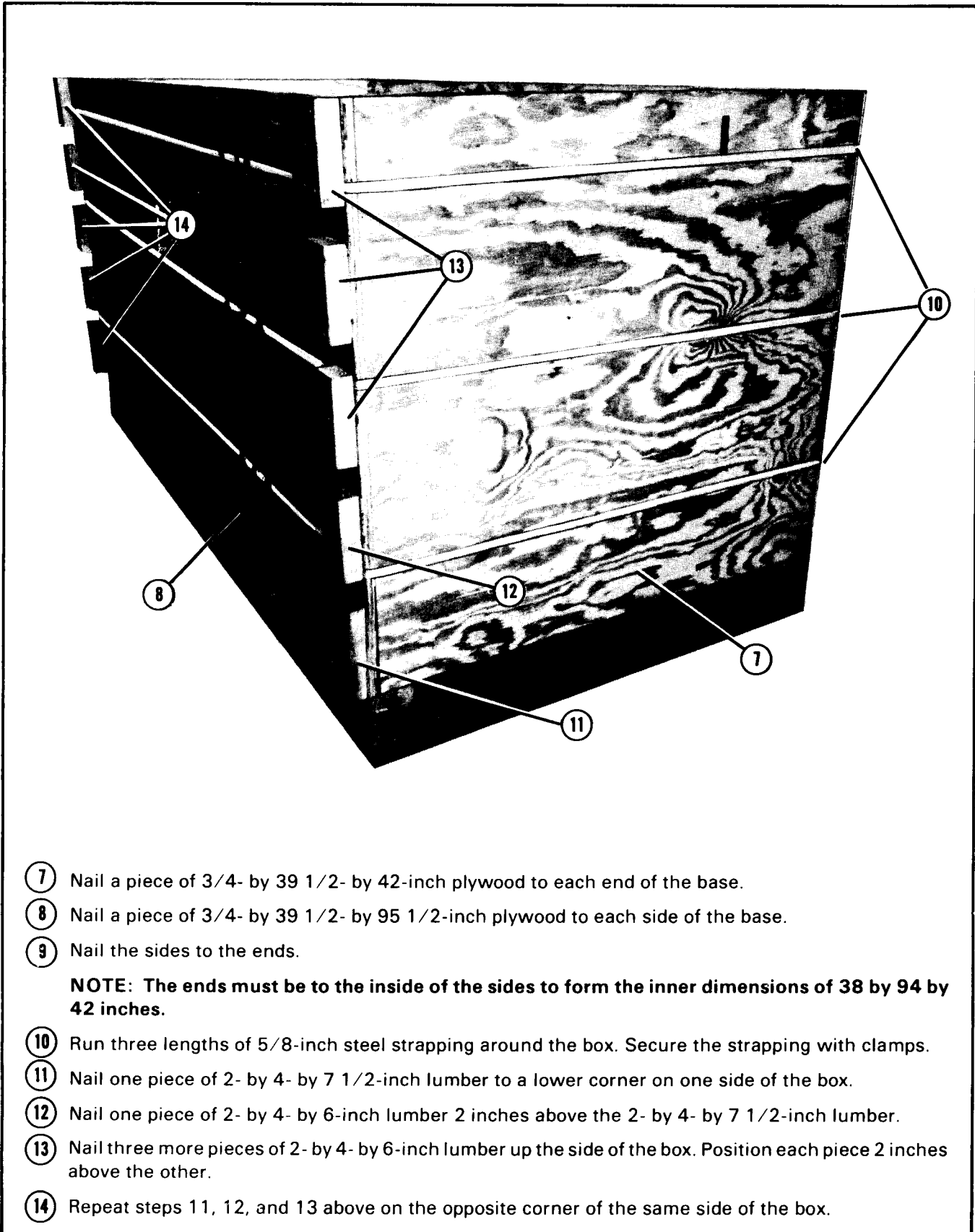

- ⑦ Nail a piece of 3/4- by 39 1/2- by 42-inch plywood to each end of the base.
  - ⑧ Nail a piece of 3/4- by 39 1/2- by 95 1/2-inch plywood to each side of the base.
  - ⑨ Nail the sides to the ends.
- NOTE: The ends must be to the inside of the sides to form the inner dimensions of 38 by 94 by 42 inches.**
- ⑩ Run three lengths of 5/8-inch steel strapping around the box. Secure the strapping with clamps.
  - ⑪ Nail one piece of 2- by 4- by 7 1/2-inch lumber to a lower corner on one side of the box.
  - ⑫ Nail one piece of 2- by 4- by 6-inch lumber 2 inches above the 2- by 4- by 7 1/2-inch lumber.
  - ⑬ Nail three more pieces of 2- by 4- by 6-inch lumber up the side of the box. Position each piece 2 inches above the other.
  - ⑭ Repeat steps 11, 12, and 13 above on the opposite corner of the same side of the box.

Figure 2-4. Wooden box prepared (continued)

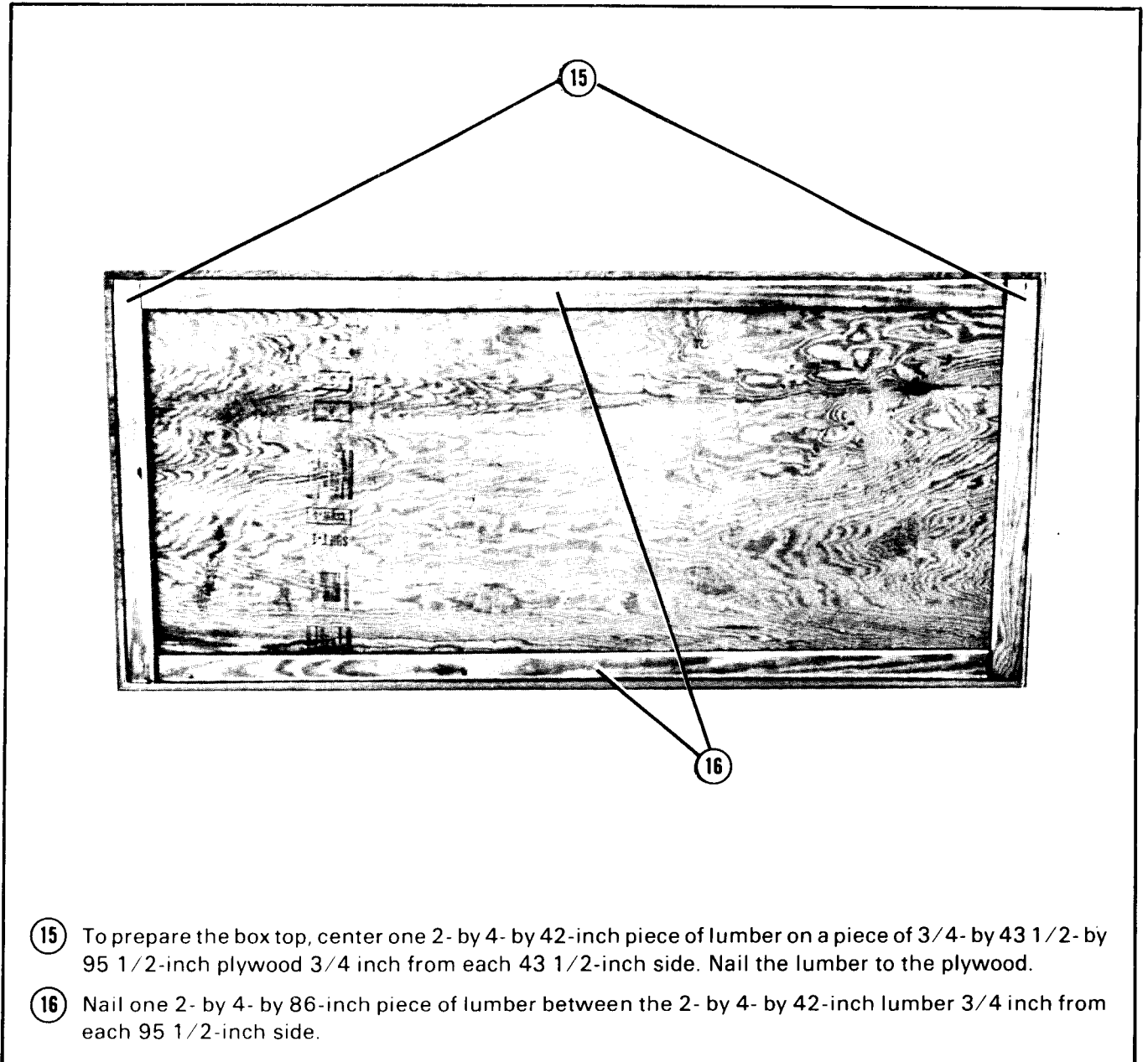

Figure 2-4. Wooden box prepared (continued)

### 2-5. Positioning and Lashing Wooden Boxes

Position and lash four wooden boxes on the honeycomb as shown in Figure 2-5. Lash the boxes in pairs using eighteen 48-foot lengths of type X nylon webbing, 36 D-rings, and 18 load binders. Position four lashings to be used later for securing the wooden box tops. Position the remaining 14 lashings, and fasten them immediately after they have been positioned on each pair of boxes. Fit all

D-rings and close all load binders according to FM 10-500/TO 13C7-1-5.

#### CAUTION

Positioning of the load binders is critical  
Place the load binders exactly where shown.



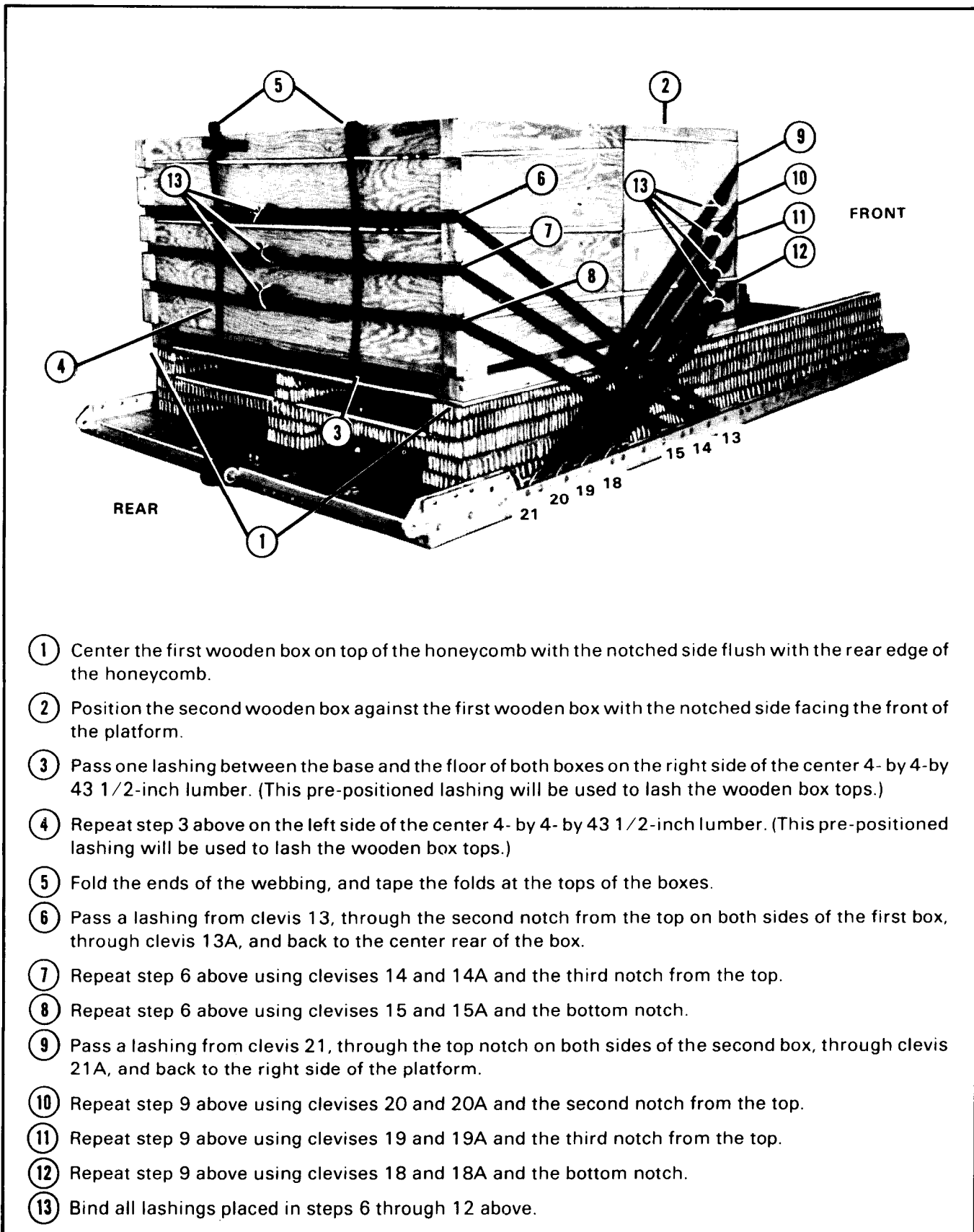
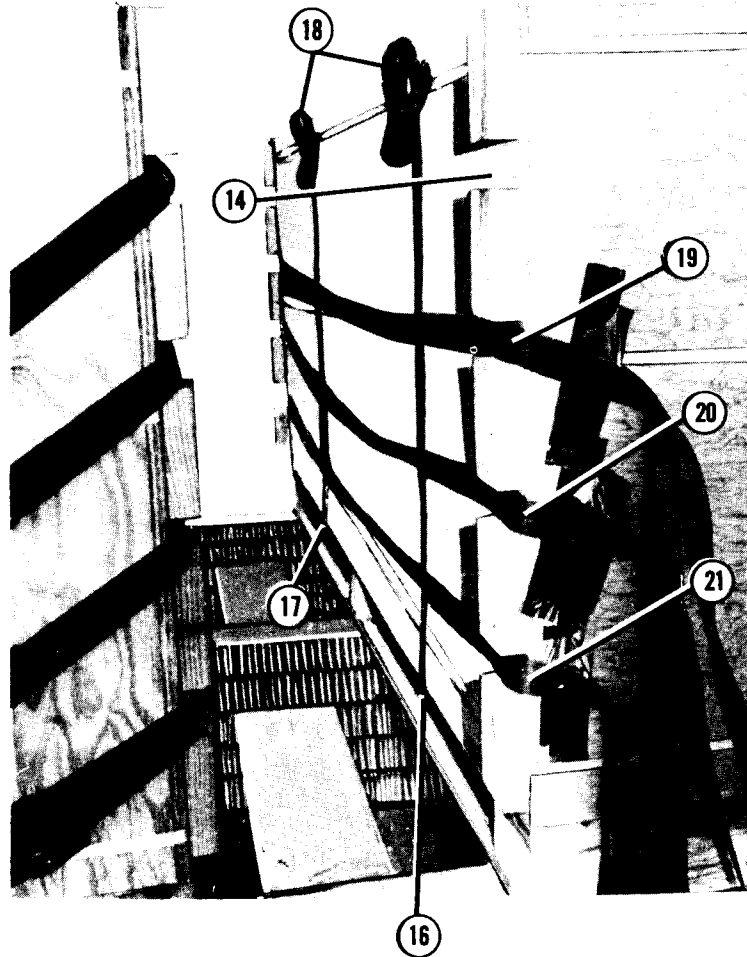
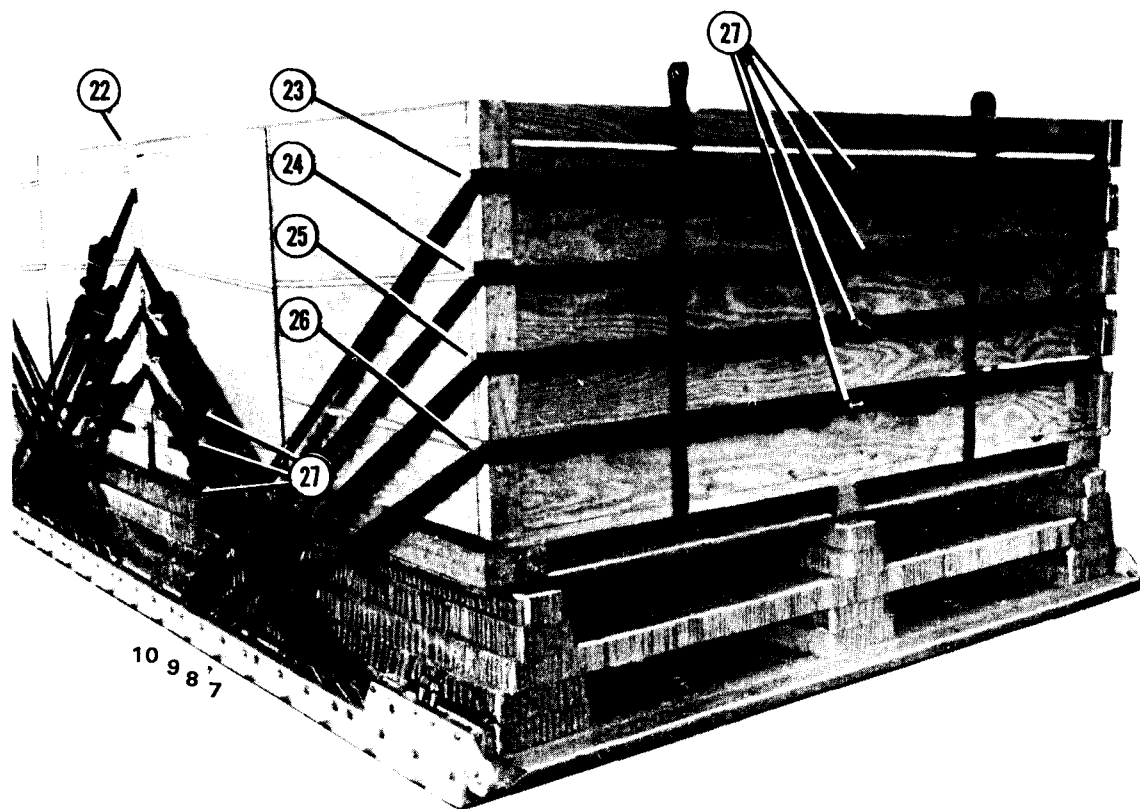

Figure 2-5. Wooden boxes positioned and lashed



- 14 Position the third wooden box on top of the honeycomb with the notched side 24 inches from the front of the second box.
- 15 Position the fourth wooden box against the third box with the notched side facing the front of the platform (not shown).
- 16 Pass one lashing between the base and the floor of both boxes on the right side of the center 4- by 4- by 43 1/2-inch lumber. (This pre-positioned lashing will be used to lash the wooden box tops.)
- 17 Repeat step 3 on the left side of the center 4- by 4- by 43 1/2-inch lumber. (This pre-positioned lashing will be used to lash the wooden box tops.)
- 18 Fold the ends of the webbing, and tape the folds at the tops of the boxes.
- 19 Pass a lashing from clevis 2, through the second notch from the top on both sides of the third box, through clevis 2A, and back to the right side of the platform. Tape the lashing to the side of the box.
- 20 Repeat step 19 above using clevises 3 and 3A and the third notch from the top.
- 21 Repeat step 19 above using clevises 4 and 4A and the bottom notch.

Figure 2-5. Wooden boxes positioned and lashed (continued)



- ② Push the third and fourth wooden boxes flush against the second box.
- ③ Pass a lashing from clevis 10, through the top notch on both sides of the fourth box, through clevis 10A, and back to the center front of the box.
- ④ Repeat step 23 above using clevises 9 and 9A and the second notch from the top.
- ⑤ Repeat step 23 above using clevises 8 and 8A and the third notch from the top.
- ⑥ Repeat step 23 above using clevises 7 and 7A and the bottom notch.
- ⑦ Remove the tape from the lashings placed in steps 19, 20, and 21. Bind lashings placed in steps 19, 20, and 21 first; then bind lashings placed in steps 23 through 26.

Figure 2-5. Wooden boxes positioned and lashed (continued)

## 2-6. Packing Blood in Cardboard Containers

Pack whole blood in cardboard containers as shown in Figure 2-6. Eighty containers are required for this load.

### CAUTION

Because whole blood is a perishable item, there must be coordination between rigging personnel and medical personnel before the blood is shipped to the rigging site.

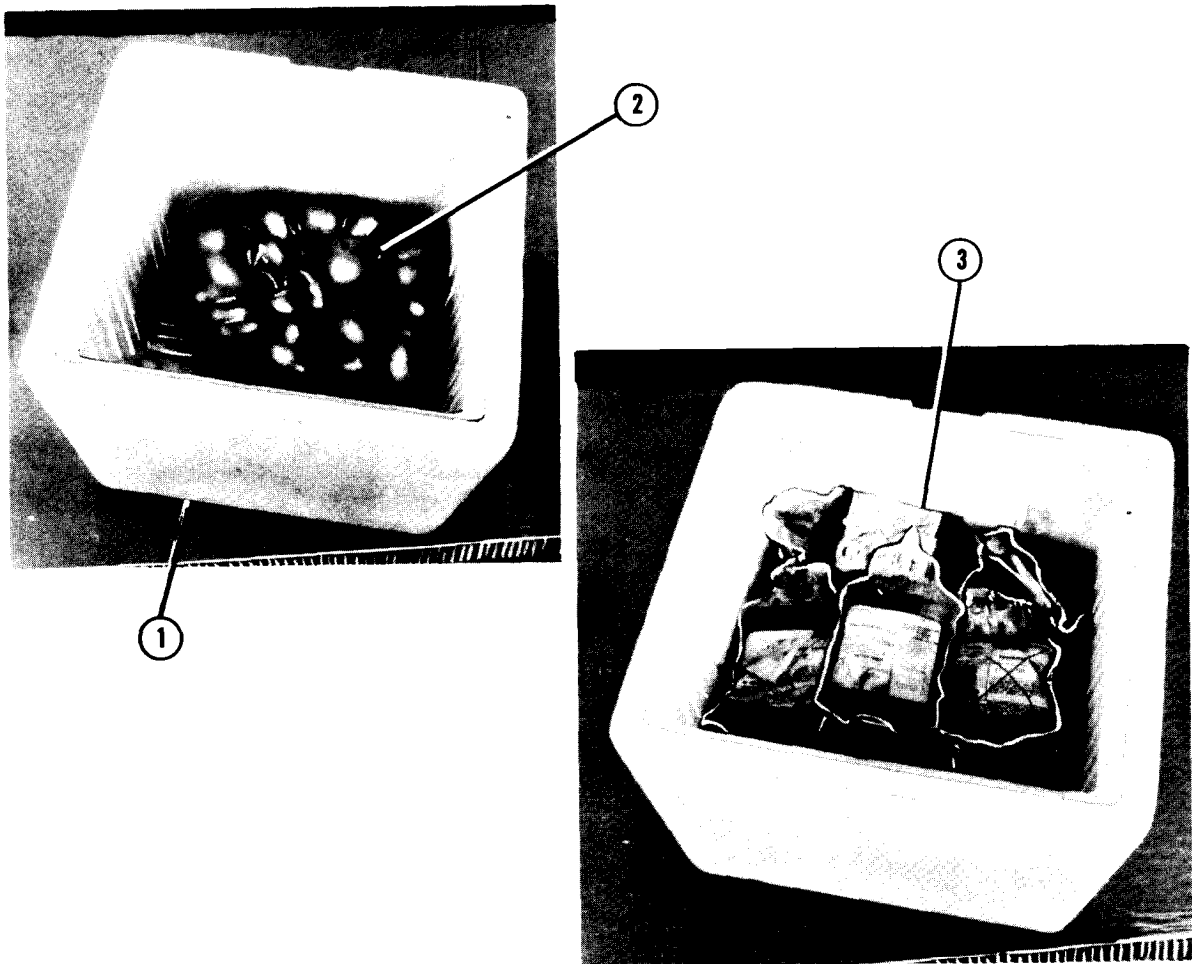

- ① Place one Styrofoam cooler on a flat, dry surface. Remove the cooler top.
- ② Put 12 to 14 pounds of ice in a double plastic bag. Seal the bag, and lay it in the bottom of the cooler.
- ③ Place 25 to 35 units of blood into the cooler on top of the ice.

*Figure 2-6. Blood packed in cardboard containers*

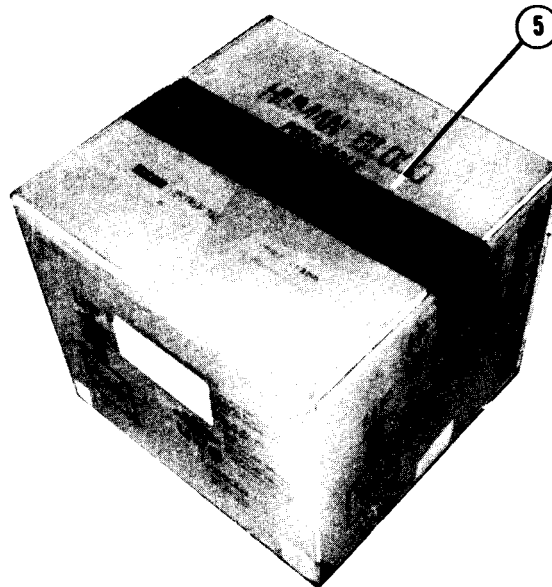
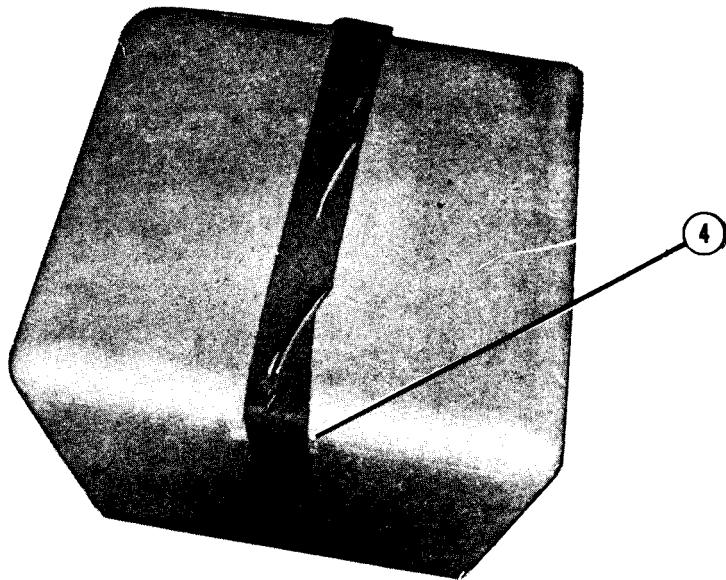

④ Replace the cooler top. Secure the top with tape.

⑤ Place the cooler into a cardboard container. Tape the top closed at the seams.

**NOTE: Hereafter, the cardboard containers packed with blood will be referred to as blood containers.**

*Figure 2-6. Blood packed in cardboard containers (continued)*

## 2-7. Packing Blood Containers in Wooden Boxes

Once the blood containers are delivered to the rigging site, pack them in the wooden boxes as shown in Figure 2-7.

**a. Filling Wooden Boxes.** Fill the wooden boxes with blood containers as shown in Figure 2-7.

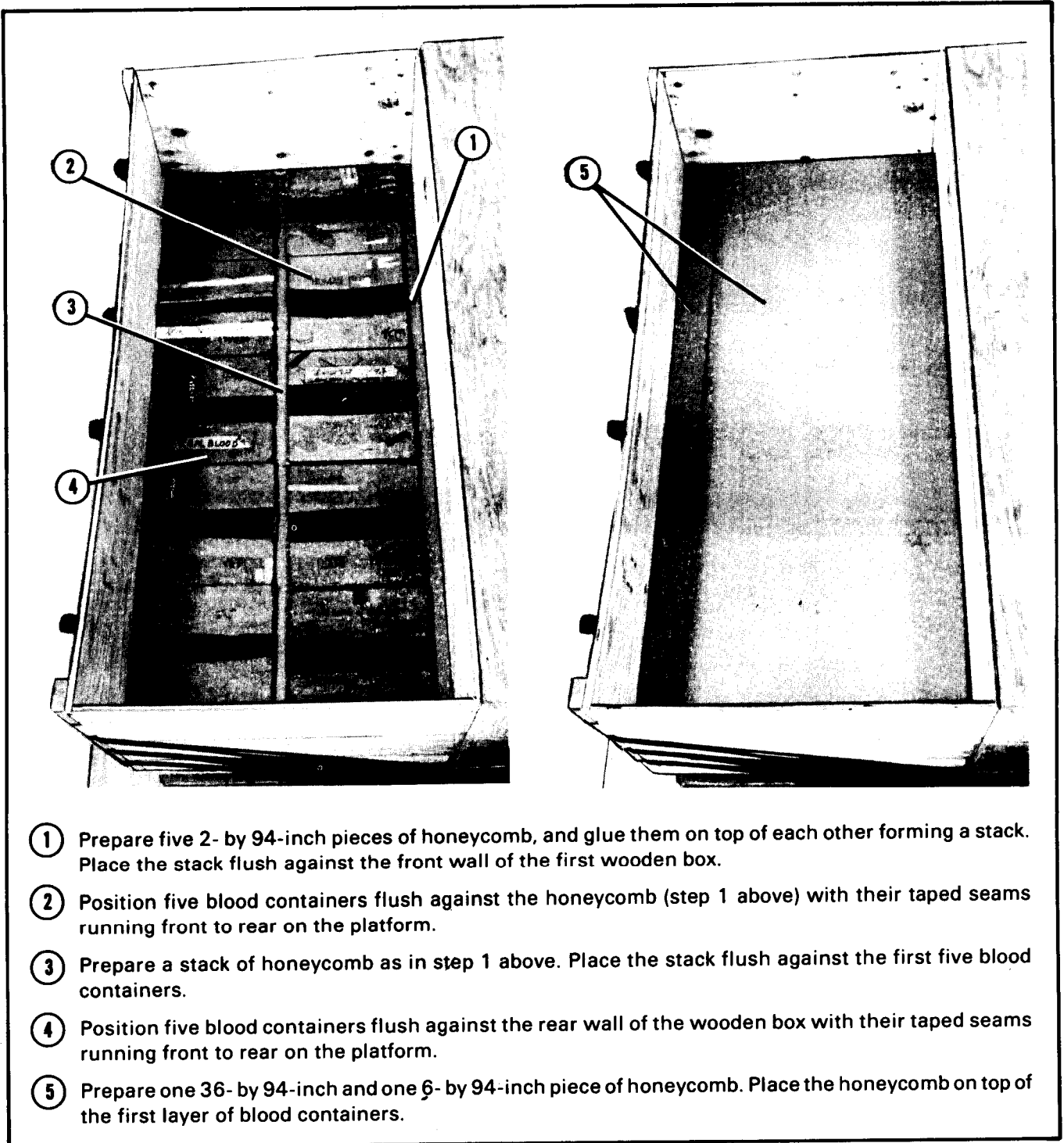
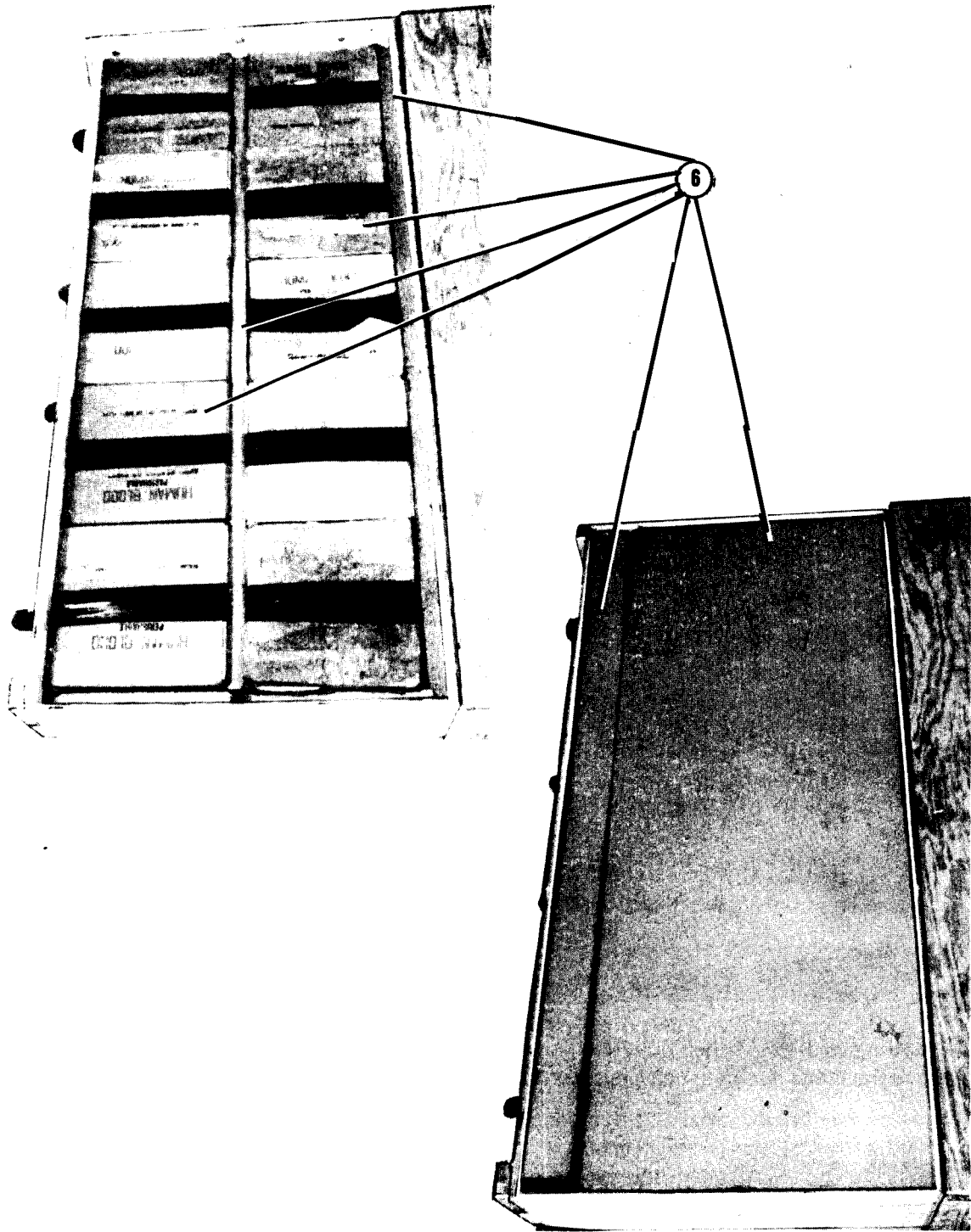

Figure 2-7. Wooden box filled with blood containers



⑥ Repeat steps 1 through 5 for the second layer of blood containers.

**NOTE:** Use honeycomb to fill any open space within the walls of the box.

*Figure 2-7. Wooden box filled with blood containers (continued)*

**b. Positioning and Lashing Wooden Box Tops**  
**Tops.** Position and lash the wooden box tops prepared as shown in Figure 2-8. Lash the wooden box tops in pairs using the four pre-positioned lashings from Figure 2-5. Fit all D-rings and close all load binders according to FM 10-500/TO 13C7-1-5.

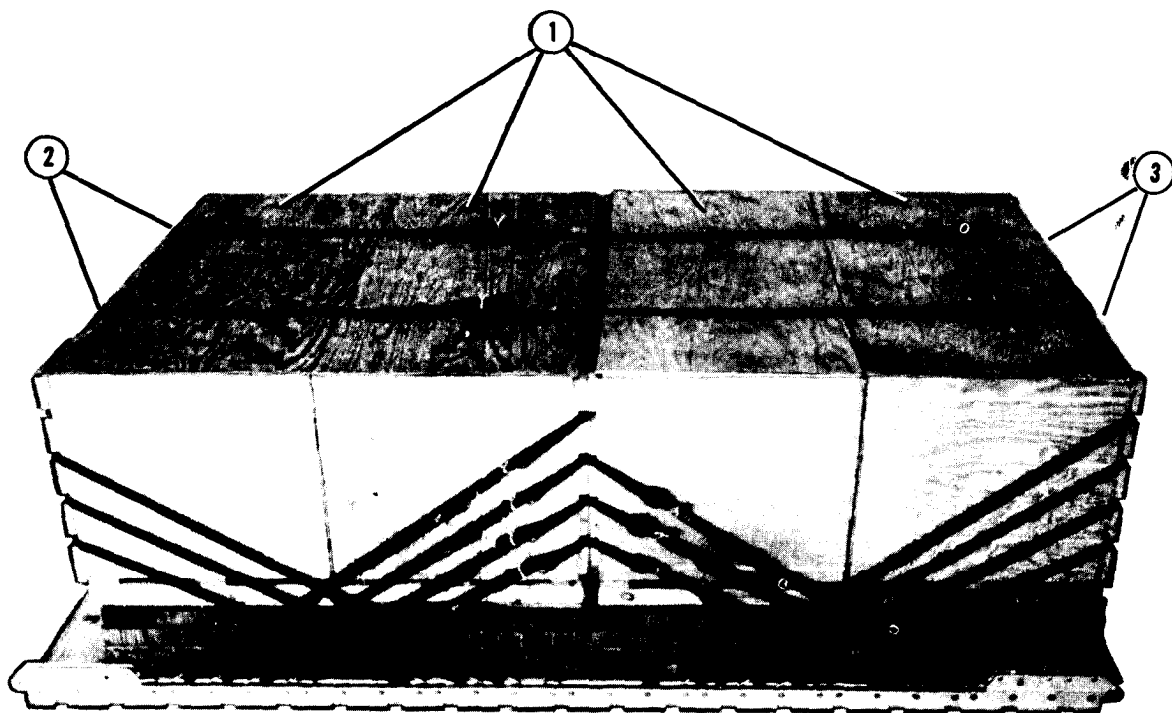

- ① Place all four wooden box tops on the boxes.
- ② Pass the pre-positioned lashings up over the tops of the first and second boxes. Bind the lashings on top of the second box.
- ③ Pass the pre-positioned lashings up over the tops of the third and fourth boxes. Bind the lashings on top of the fourth box.

*Figure 2-8. Wooden box tops positioned and lashed*



**c. Positioning and Fastening Vertical Lashings.** Position and fasten the vertical lashings as shown in Figure 2-9. Use eight 48-foot lengths of type X nylon webbing, 16 D-rings, and 8 load binders. Fit all D-rings and close all load binders according to FM 10-500/TO 13C7-1-5.

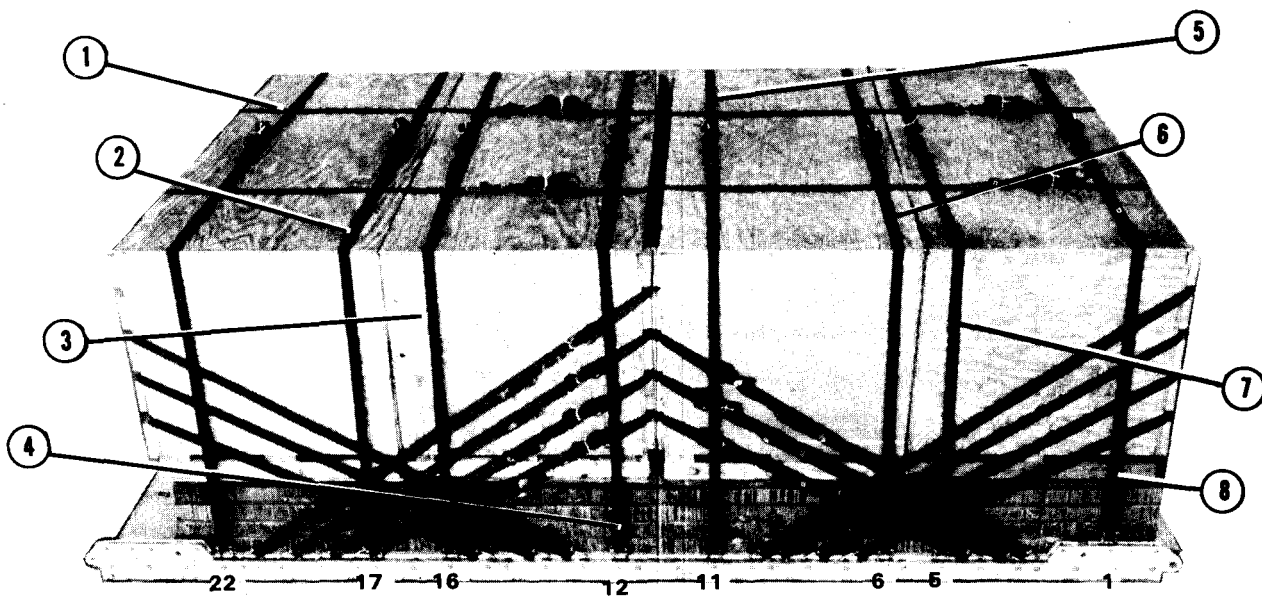

- ① Pass a lashing through clevis 22, over the top of the first wooden box, through clevis 22A, and back to the center rear of the box top. Bind the lashing.
- ② Repeat step 1 above using clevises 17 and 17A and the center front of the box top.
- ③ Pass a lashing through clevis 16, over the top of the second wooden box, through clevis 16A, and back to the center rear of the box top. Bind the lashing.
- ④ Repeat step 3 above using clevises 12 and 12A and the center front of the box top.
- ⑤ Pass a lashing through clevis 11, over the top of the third wooden box, through clevis 11A and back to the center rear of the box top. Bind the lashing.
- ⑥ Repeat step 5 above using clevises 6 and 6A and the center front of the box top.
- ⑦ Pass a lashing through clevis 5, over the top of the fourth wooden box, through clevis 5A, and back to the center rear of the box top. Bind the lashing.
- ⑧ Repeat step 7 above using clevises 1 and 1A and the center front of the box top.

*Figure 2-9. Vertical lashings positioned and fastened*

## 2-8. Installing Suspension Slings

Use four large clevises and four 20-foot (2-loop), type XXVI nylon webbing slings for suspension. Bolt and safety the slings as shown in Figure 2-10.

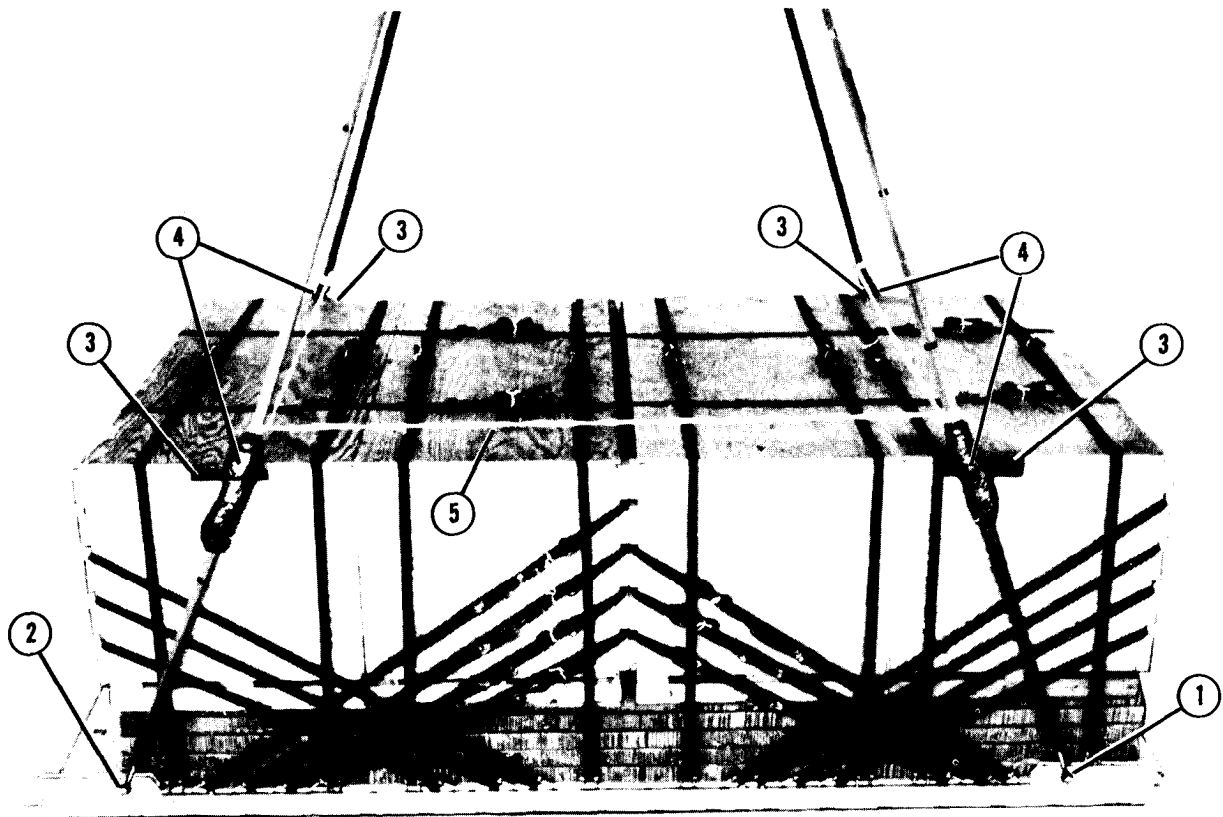

- ① Bolt a 20-foot sling to each front tandem link with a large clevis.
- ② Bolt a 20-foot sling to each rear tandem link with a large clevis.
- ③ Raise the slings. Tape all areas on the boxes where the slings make contact.
- ④ Use an 18-inch length of 1/2-inch felt or cellulose wadding to pad each sling 40 inches above its point of attachment. Tape the felt or cellulose wadding to the slings.
- ⑤ Safety the slings with a deadman's tie according to FM 10-500/TO 13C7-1-5. Make the tie 4 to 6 inches above the top of the load.

*Figure 2-10. Suspension slings installed*

## 2-9. Stowing Cargo Parachutes

Stow the cargo parachutes as shown in Figure 2-11.

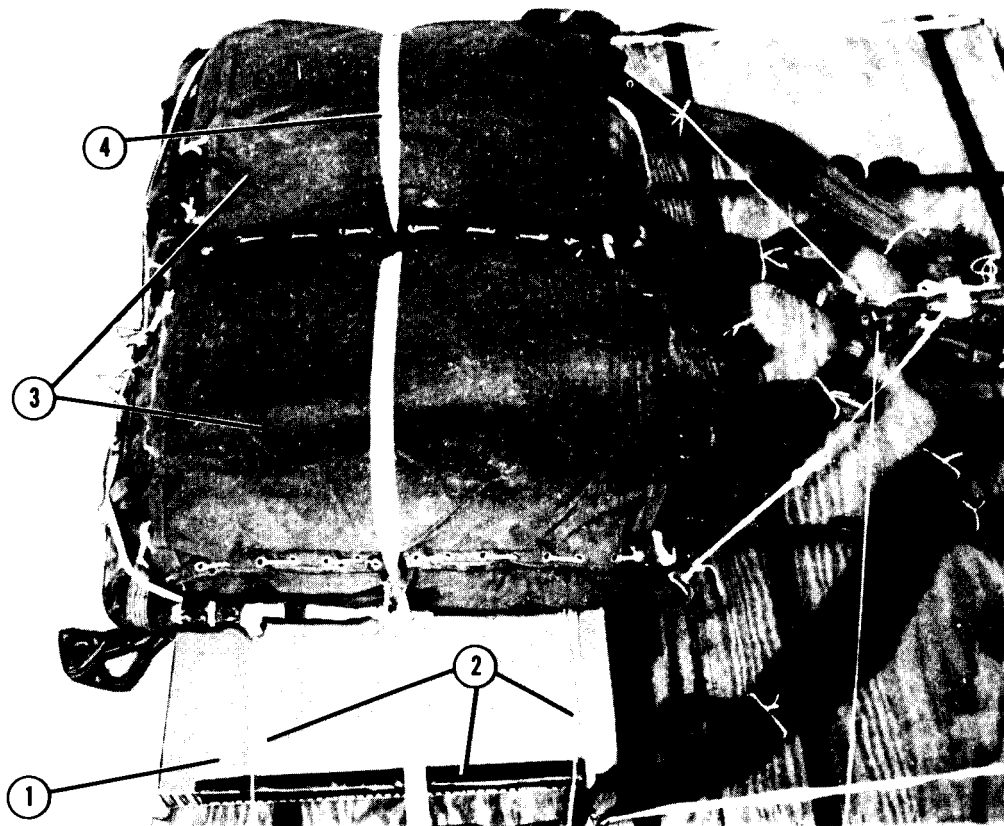

- ① Lower the suspension slings. Lay one piece of 36- by 95-inch honeycomb on top of the load flush with its rear edge.
- ② Tape the left and right edges of the honeycomb. Secure the honeycomb with two lengths of type III nylon cord to convenient clevises.
- ③ Prepare and stow two G-11A or two G-11B cargo parachutes according to FM 10-500/TO 13C7-1-5, and set them on top of the honeycomb.
- ④ Use a length of type VIII nylon webbing as a parachute restraint strap.

*Figure 2-11. Cargo parachutes stowed*

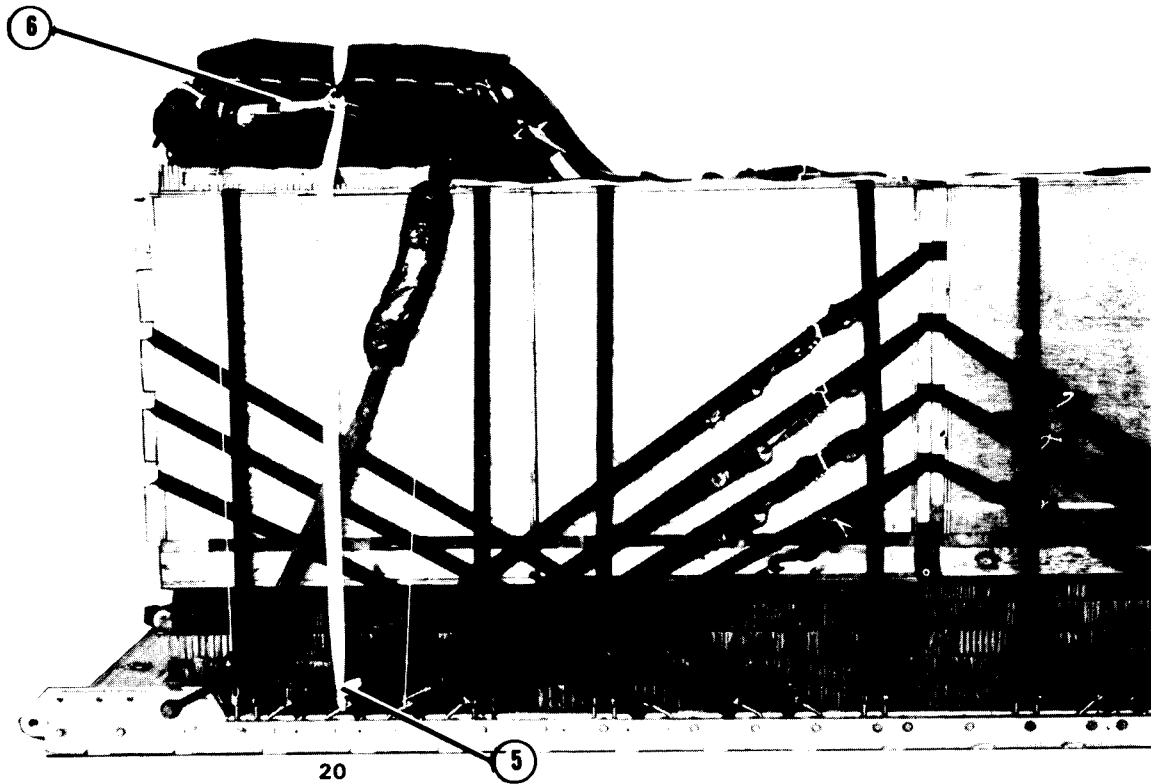

- ⑤ Tie the parachute restraint strap to clevises 20 and 20A according to FM 10-500/TO 13C7-1-5.
- ⑥ Install two multicut parachute release straps according to FM 10-500/TO 13C7-1-5.

*Figure 2-11. Cargo parachutes stowed (continued)*

## 2-10. Installing Release System

Prepare, attach, and safety an M-1 cargo parachute release according to FM 10-500/TO 13C7-1-5 and as shown in Figure 2-12.

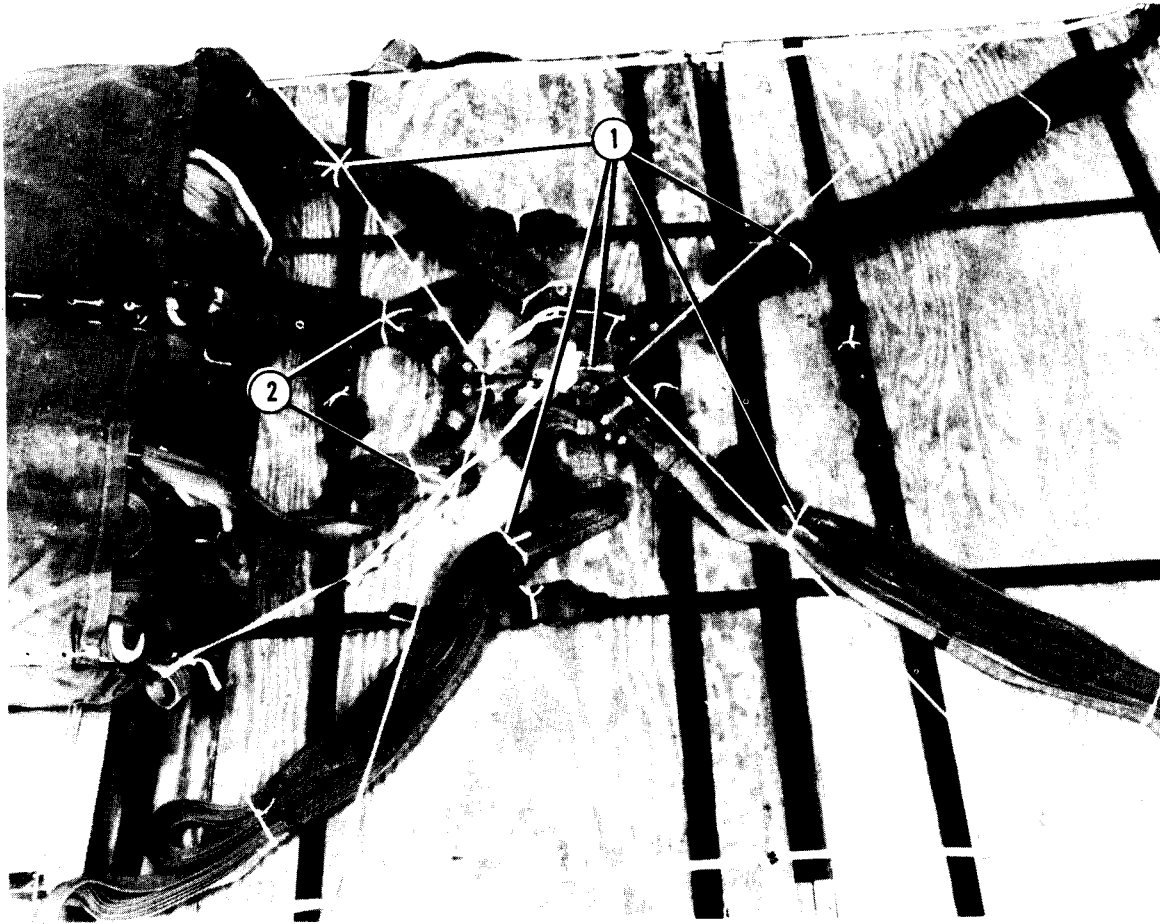

- ① Place the M-1 release on the plywood. S-fold the excess parachute risers and tie the folds in place with 80-pound cotton webbing according to FM 10-500/TO 13C7-1-5.
- ② S-fold the excess suspension slings, and tie the folds in place with 80-pound cotton webbing.

*Figure 2-12. M-1 cargo parachute release installed*

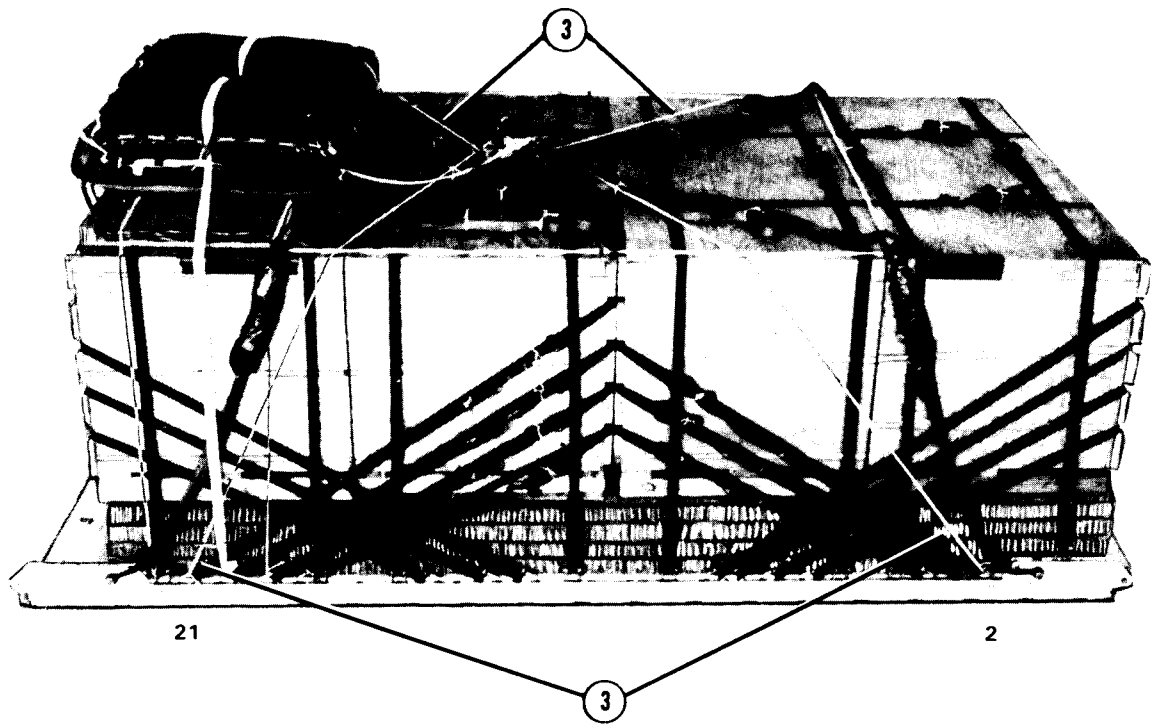

③ Safety the M-1 release to clevises 2, 2A, 21, and 21A with type III nylon cord.

*Figure 2-12. M-1 cargo parachute release installed (continued)*

### 2-11. Installing Extraction System and Emergency Restraint Clevises

Use the EFTC extraction system for this load. Install the system according to FM 10-500/TO 13C7-1-5 and as shown in Figure 2-13. Install the emergency restraint clevises as shown in Figure 2-13.

### 2-12. Placing Extraction Parachute

Place the extraction parachute as given below.

**a. C-130 Aircraft.** Place an unreefed 15-foot cargo extraction parachute with a 60-foot (1-loop), type XXVI nylon webbing extraction line on the load for installation in the aircraft.

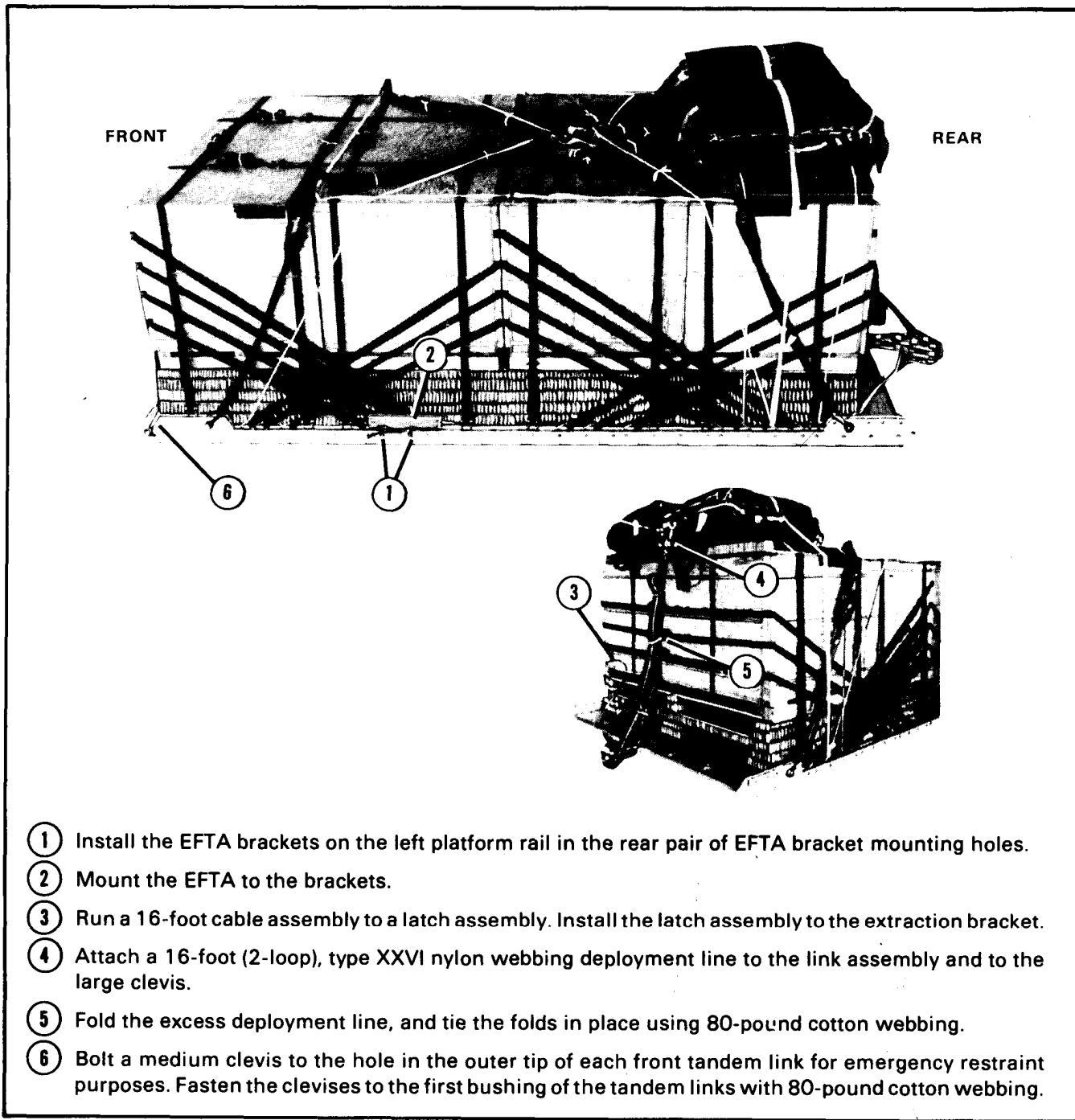

- ① Install the EFTA brackets on the left platform rail in the rear pair of EFTA bracket mounting holes.
- ② Mount the EFTA to the brackets.
- ③ Run a 16-foot cable assembly to a latch assembly. Install the latch assembly to the extraction bracket.
- ④ Attach a 16-foot (2-loop), type XXVI nylon webbing deployment line to the link assembly and to the large clevis.
- ⑤ Fold the excess deployment line, and tie the folds in place using 80-pound cotton webbing.
- ⑥ Bolt a medium clevis to the hole in the outer tip of each front tandem link for emergency restraint purposes. Fasten the clevises to the first bushing of the tandem links with 80-pound cotton webbing.

Figure 2-13. EFTC extraction system and emergency restraint clevises installed

**b. C-141 Aircraft.** Place an unreefed 15-foot cargo extraction parachute with a 36-inch adapter web and a continuous 160-foot (l-loop), type XXVI nylon webbing extraction line on the load for installation in the aircraft. Use a type IV link to connect the line to the adapter web.

**2-13. Marking Rigged Load**

Mark the rigged load according to FM 10-500/TO 13C7-1-5 and as shown in Figure 2-14. If the load varies from the one shown in Figure 2-14, the height, weight, CB, and parachute requirements must be recomputed.

**NOTES:**

1. The extraction line **MUST** be a continuous 160-foot, type XXVI nylon webbing extraction line. Shorter lines **WILL NOT** be used to form the 160-foot extraction line.
2. Use a deployment line bag.

**CAUTION**

Make the final rigger inspection required by FM 10-500 TO 13C7-1 5 before the load leaves the rigging site.



clb

**RIGGED LOAD DATA**

Weight:	Load shown .....	7,680 pounds
	Maximum allowed .....	7,906 pounds
Height .....		80 inches
Width .....		108 inches
Length .....		212 inches
Overhang: Rear .....		20 inches
CB (from front edge of platform).....		100 inches

*Figure 2-14. Whole blood rigged for low-velocity airdrop on a type V airdrop platform*



**2-14. Equipment Required**

Use the equipment listed in Table 2-1 to rig this load.

*Table 2-1. Equipment required for rigging whole blood for low-velocity airdrop on a type V platform*

National Stock Number	Item	Quantity
8040-00-273-8713	Adhesive, paste, 1-gal	As required
3990-00-937-0272	Binder, load, 10,000-lb	26
	Clevis, suspension:	
4030-00-678-8562	3/4-in (medium)	2
4030-00-090-5354	1-in (large)	4
4020-00-240-2146	Cord, nylon, type III, 550-lb	As required
1670-00-434-5785	Coupling, airdrop, extraction force transfer, w 16-ft cable	1
8135-00-664-6958	Cushioning material, packaging, cellulose wadding	As required
5365-00-937-0147	D-ring, heavy-duty, 10,000-lb	52
8305-00-958-3685	Felt, 1/2-in thick	As required
1670-01-183-2678	Leaf, extraction line (line bag)	1
	Line, extraction, type XXVI nylon webbing:	
1670-01-064-4452	60-ft (1-loop) (for C-130)	1
1670-01-107-7652	160-ft (1-loop) (for C-141)	1
1670-00-783-5988	Link assembly, type IV (for extraction line)	1
5510-00-220-6146	Lumber, 2- by 4-in:	
	6-in	32
	7 1/2-in	8
	42-in	8
	86-in	8
	95 1/2-in	12
5510-00-220-6274	Lumber, 4- by 4- by 43 1/2-in	20
	Nail, steel wire, common:	
5315-00-162-3151	4d	As required
5315-00-010-4657	6d	As required
5315-00-010-4659	8d	As required
5315-00-010-4661	10d	As required
1670-00-753-3928	Pad, energy-dissipating, honeycomb,	
	3- by 36- by 96-in:	22 sheets
	2- by 94-in	(80)
	4- by 90-in	(6)
	6- by 90-in	(6)
	6- by 94-in	(8)
	8- by 7 1/2-in	(3)
	8- by 84 1/2-in	(3)
	10- by 90-in	(6)
	12- by 90-in	(6)
	36- by 94-in	(8)
	36- by 95-in	(1)
	91 1/2- by 8-in	(3)

Table 2-1. Equipment required for rigging whole blood for low-velocity airdrop on a type V platform (continued)

National Stock Number	Quantity	Item
	Parachute:	
	Cargo:	
1670-00-269-1107	G-11A <u>or</u>	2
1670-01-016-7841	G-11B	2
	Cargo extraction:	
1670-00-052-1548	15-ft <u>or</u>	1
1670-01-063-3715	15-ft	1
	Platform, airdrop, type V, 16-ft:	1
1670-01-162-2375	Bracket, inside EFTA	(1)
1670-01-162-2374	Bracket, outside EFTA	(1)
1670-01-162-2372	Clevis, load tiedown	(46)
1670-01-162-2376	Extraction bracket assembly	(1)
1670-01-162-2381	Tandem link	(4)
5530-00-128-4981	Plywood, 3/4-in:	
	39 1/2- by 42-in	8
	39 1/2- by 95 1/2-in	8
	42- by 94-in	4
	43 1/2- by 95 1/2-in	8
1670-01-097-8816	Release, cargo parachute, M-1	1
	Sling, cargo, airdrop:	
	For deployment line:	
1670-00-823-5042	16-ft (3-loop), type X nylon webbing <u>or</u>	1
1670-01-063-7761	16-ft (2-loop), type XXVI nylon webbing	1
	For riser extensions:	
1670-00-753-3794	20-ft (2-loop), type X nylon webbing <u>or</u>	2
1670-01-062-6302	20-ft (2-loop), type XXVI nylon webbing	2
	For suspension:	
1670-00-823-5043	20-ft (3-loop), type X nylon webbing <u>or</u>	4
1670-01-062-6302	20-ft (2-loop), type XXVI nylon webbing	4
1670-00-040-8219	Strap, parachute release, multicut, comes w 3 knives	2
8135-00-283-0667	Strapping, steel, 5/8-in	As required
7510-00-266-5016	Tape, adhesive, 2-in	As required
	Webbing:	
8305-00-268-2411	Cotton, 80-lb	As required
8305-00-082-5752	Nylon, tubular, 1/2-in, 1,000-lb, natural	As required
8305-00-263-3591	Nylon, type VIII, 3,600-lb	As required
8305-00-261-8584	Nylon, type X, treated, 8,700-lb, olive drab	As required

Section II  
**RIGGING BLOOD FOR LAPE AIRDROP**

**2-15. Description of Load**

Whole blood is rigged on a 16-foot, type V airdrop platform with one 28-foot extraction parachute (packed for LAPE) and one 15-foot extraction parachute (drogue) for C-130 aircraft.

**2-16. Preparing Platform**

Prepare a 16-foot, type V airdrop platform as described below.

**a. Assembling and Inspecting Platform.** Inspect, or assemble and inspect, the platform as outlined in TM 10-1670-268-20&P/TO 13C7-52-22.

**b. Installing Tandem Links.** Install a tandem link on the front of each rail as shown in Figure 2-15.

**c. Attaching and Numbering Clevises.** Bolt 52 tiedown clevises to the side rail bushings and tandem links according to TM 10-1670-268-20&P/TO 13C7-52-22 and as shown in Figure 2-15. Number the clevises as shown in Figure 2-15.

**NOTE:** The nose bumper must be installed.

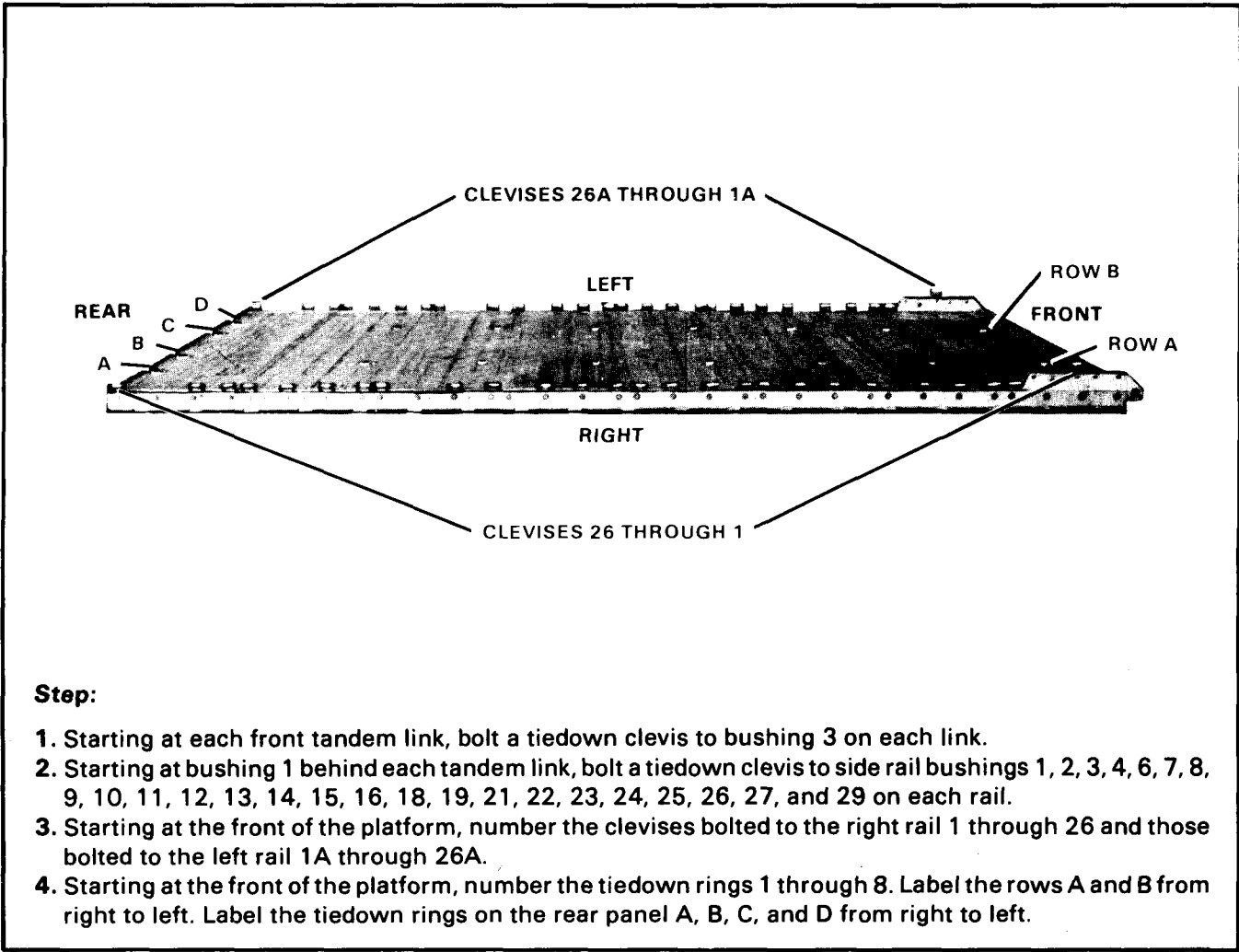

- Step:**
1. Starting at each front tandem link, bolt a tiedown clevis to bushing 3 on each link.
  2. Starting at bushing 1 behind each tandem link, bolt a tiedown clevis to side rail bushings 1, 2, 3, 4, 6, 7, 8, 9, 10, 11, 12, 13, 14, 15, 16, 18, 19, 21, 22, 23, 24, 25, 26, 27, and 29 on each rail.
  3. Starting at the front of the platform, number the clevises bolted to the right rail 1 through 26 and those bolted to the left rail 1A through 26A.
  4. Starting at the front of the platform, number the tiedown rings 1 through 8. Label the rows A and B from right to left. Label the tiedown rings on the rear panel A, B, C, and D from right to left.

*Figure 2-15. Platform prepared*

### 2-17. Preparing and Placing Honeycomb Layers

Prepare and place the honeycomb layers as described in paragraph 2-3.

### 2-18. Preparing Wooden Boxes

Prepare four wooden boxes as described in paragraph 2-4.

### 2-19. Positioning and Lashing Wooden Boxes

Position and lash four wooden boxes on the honeycomb as shown in Figure 2-16. Lash the boxes using twenty-six 48-foot lengths of type X nylon webbing, 52 D-rings, and 26 load binders.

Position four lashings to be used later for securing the wooden box tops. Position eight lashings to be used later for securing the wooden box tops in pairs. Position the remaining 14 lashings, and fasten them immediately after they have been positioned on each pair of boxes. Fit all D-rings and close all load binders according to FM 10-500/TO 13C7-1-5.

#### CAUTION

Positioning of the load binders is critical. Place the load binders exactly where shown.

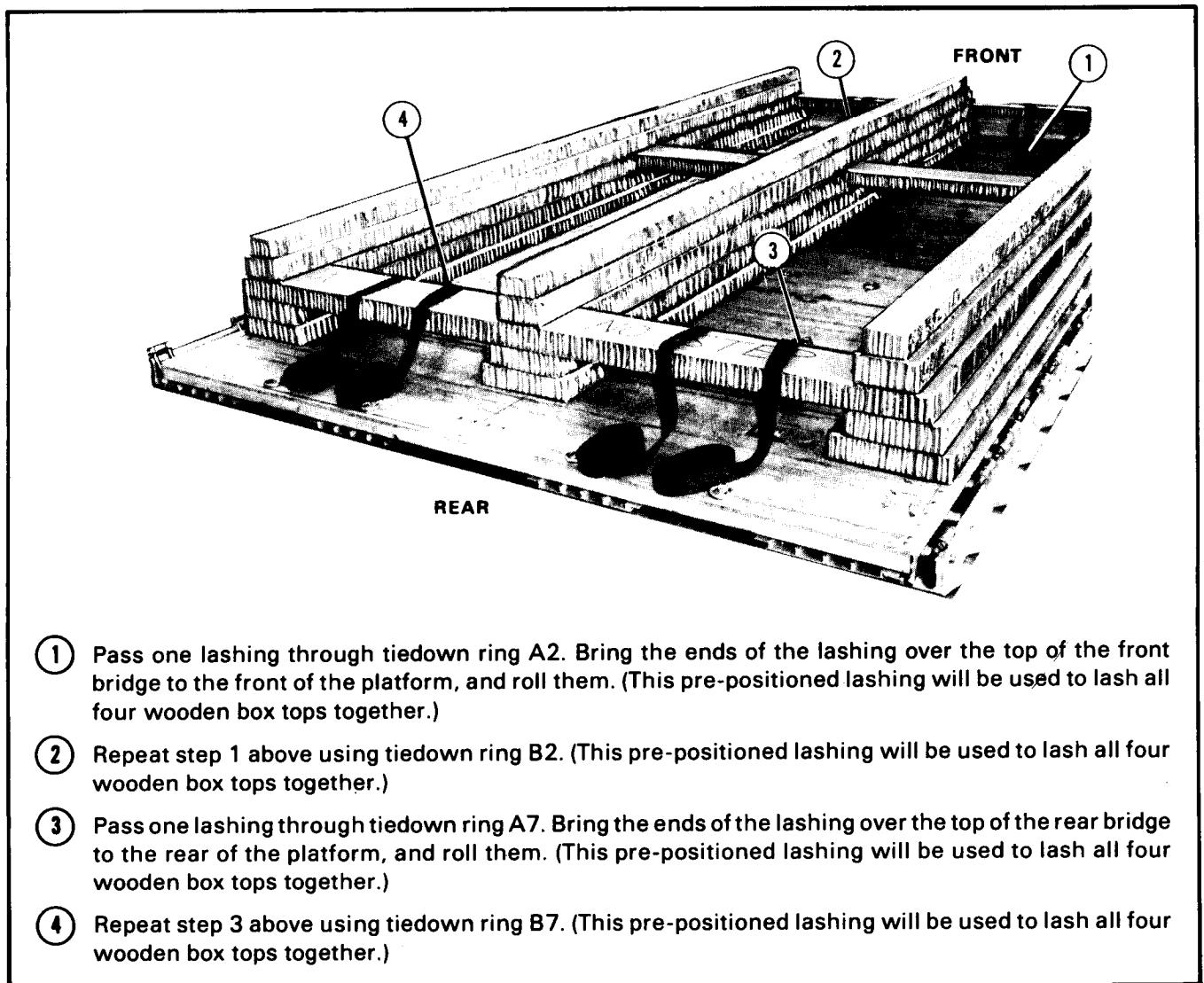

- ① Pass one lashing through tiedown ring A2. Bring the ends of the lashing over the top of the front bridge to the front of the platform, and roll them. (This pre-positioned lashing will be used to lash all four wooden box tops together.)
- ② Repeat step 1 above using tiedown ring B2. (This pre-positioned lashing will be used to lash all four wooden box tops together.)
- ③ Pass one lashing through tiedown ring A7. Bring the ends of the lashing over the top of the rear bridge to the rear of the platform, and roll them. (This pre-positioned lashing will be used to lash all four wooden box tops together.)
- ④ Repeat step 3 above using tiedown ring B7. (This pre-positioned lashing will be used to lash all four wooden box tops together.)

Figure 2-16. Wooden boxes positioned and lashed

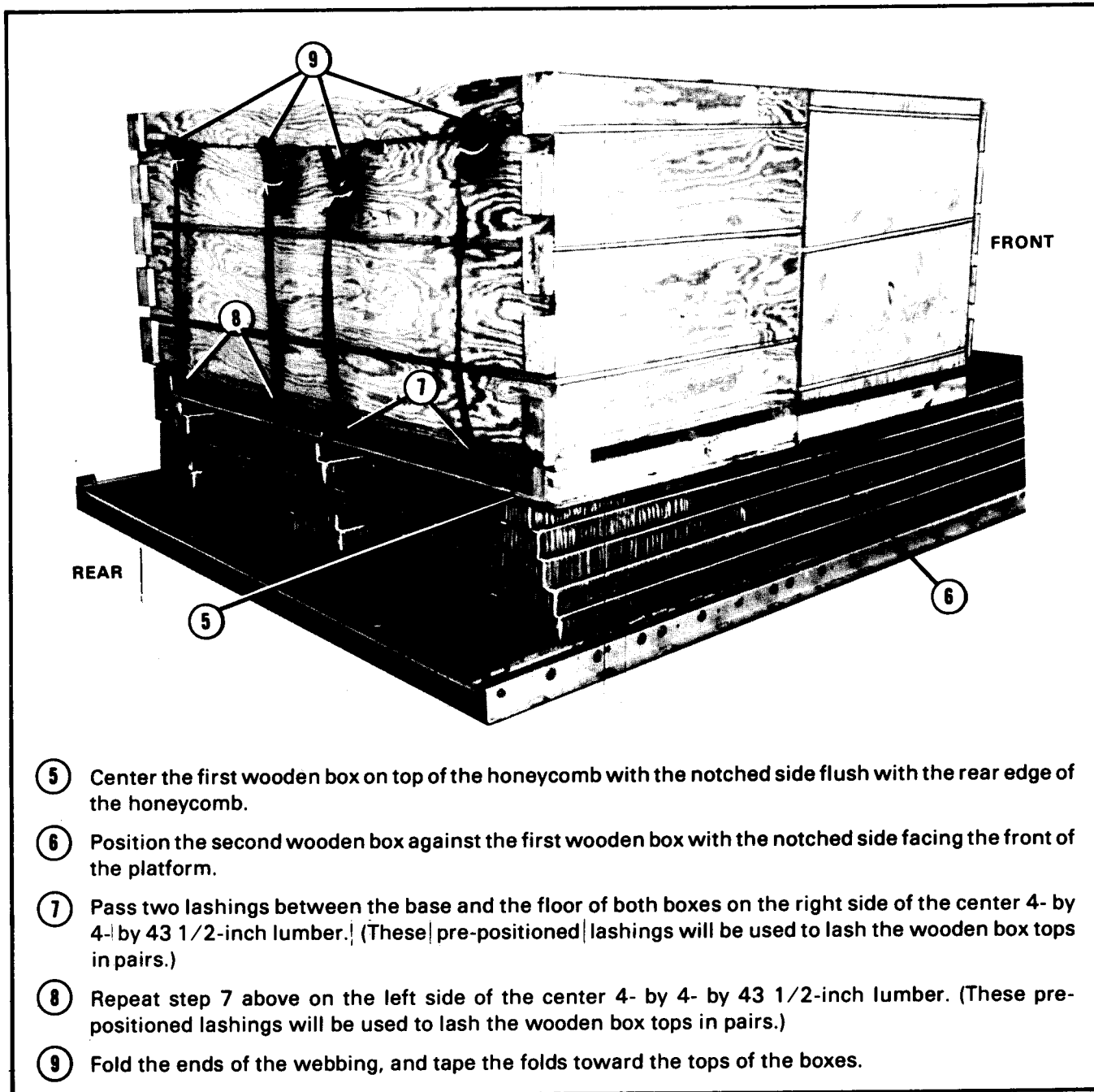

- ⑤ Center the first wooden box on top of the honeycomb with the notched side flush with the rear edge of the honeycomb.
- ⑥ Position the second wooden box against the first wooden box with the notched side facing the front of the platform.
- ⑦ Pass two lashings between the base and the floor of both boxes on the right side of the center 4- by 4- by 43 1/2-inch lumber. (These pre-positioned lashings will be used to lash the wooden box tops in pairs.)
- ⑧ Repeat step 7 above on the left side of the center 4- by 4- by 43 1/2-inch lumber. (These pre-positioned lashings will be used to lash the wooden box tops in pairs.)
- ⑨ Fold the ends of the webbing, and tape the folds toward the tops of the boxes.

Figure 2-16. Wooden boxes positioned and lashed (continued)

**NOTE: Lash the boxes in pairs.**

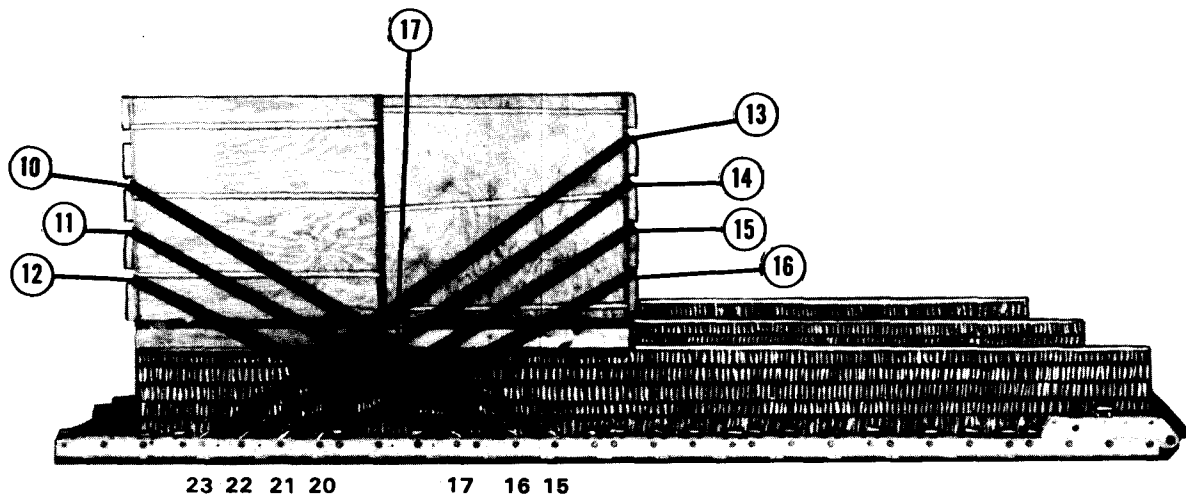

- ⑩ Pass a lashing through clevis 15, through the second notch from the top on both sides of the first box, through clevis 15A, and back through clevis 15.
- ⑪ Repeat step 10 above using clevises 16 and 16A and the third notch from the top.
- ⑫ Repeat step 10 above using clevises 17 and 17A and the bottom notch.
- ⑬ Pass a lashing through clevis 23, through the top notch on both sides of the second box, through clevis 23A, and back through clevis 23.
- ⑭ Repeat step 13 above using clevises 22 and 22A and the second notch from the top.
- ⑮ Repeat step 13 above using clevises 21 and 21A and the third notch from the top.
- ⑯ Repeat step 13 above using clevises 20 and 20A and the bottom notch.
- ⑰ Bind lashings placed in steps 10 through 16 above.

*Figure 2-16. Wooden boxes positioned and lashed (continued)*

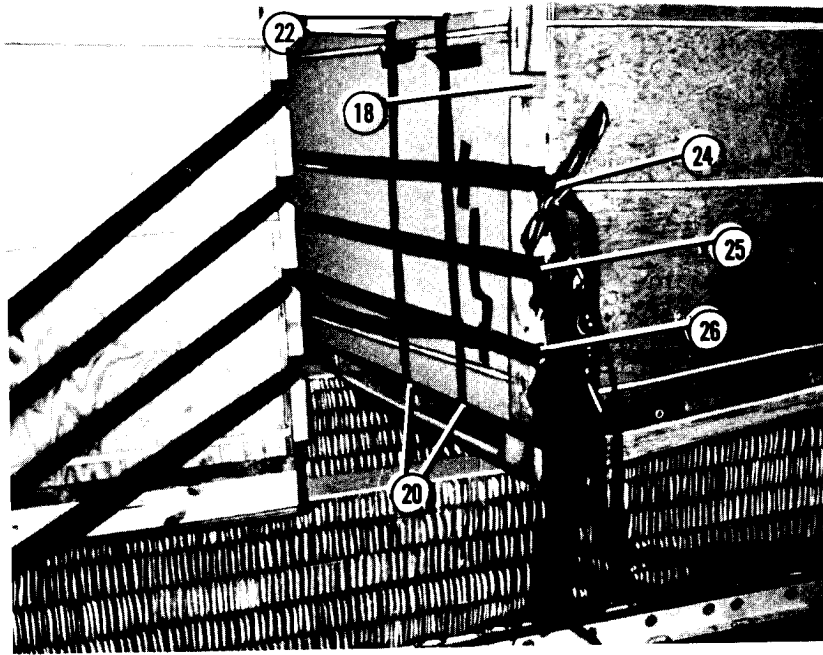

- ⑮ Position the third wooden box on top of the honeycomb with the notched side 24 inches from the front of the second box.
  - ⑯ Position the fourth wooden box against the third box with the notched side facing the front of the platform (not shown).
  - ⑰ Pass two lashings between the base and the floor of both boxes on the right side of the center 4- by 4- by 43 1/2-inch lumber. (These pre-positioned lashings will be used to lash the wooden box tops in pairs.)
  - ⑱ Repeat step 20 above on the left side of the center 4- by 4- by 43 1/2-inch lumber (not shown). (These pre-positioned lashings will be used to lash the wooden box tops in pairs.)
  - ⑳ Bring the rear ends of the webbing up the rear side of the third box. Tape the webbing in place at the top of the rear side. Lay the excess webbing into the inside of the box for later use.
  - ㉑ Fold the remaining ends of the webbing, and tape the folds toward the top of the fourth box (not shown).
- NOTE: Tape on the rear of the box is used as a rigging aid. It may or may not be removed.**
- ㉒ Pass a lashing through clevis 2, through the second notch from the top on both sides of the third box, through clevis 2A, and back to the right side of the platform. Tape the lashing to the side of the box.
  - ㉓ Repeat step 24 above using clevises 3 and 3A and the third notch from the top.
  - ㉔ Repeat step 24 above using clevises 4 and 4A and the bottom notch.

Figure 2-16. Wooden boxes positioned and lashed (continued)

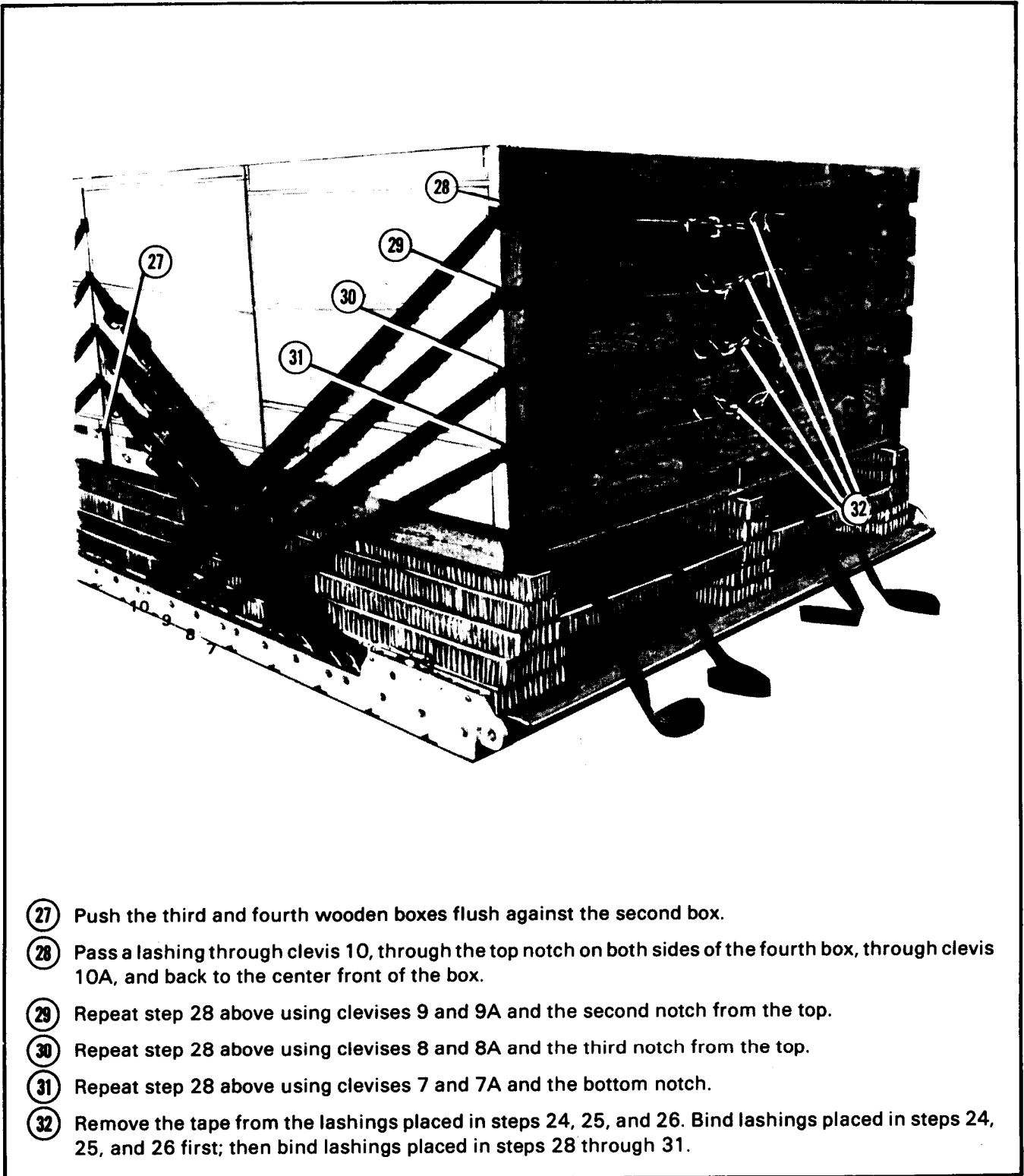

*Figure 2-16. Wooden boxes positioned and lashed (continued)*



## 2-20. Packing Blood in Cardboard Containers

Pack whole blood in cardboard containers as described in paragraph 2-6. Eighty containers are required for this load.

## 2-21. Packing Blood Containers in Wooden Boxes

Once the blood containers are delivered to the rigging site, pack them in four wooden boxes as described in paragraph 2-7 a and as shown in Figure 2-7.

**a. Positioning and Lashing Wooden Box Tops.** Position and lash the wooden box tops (prepared as shown in Figure 2-4) as shown in Figure 2-17. Lash the wooden box tops in pairs using the eight pre-positioned lashings from Figure 2-16, steps 7, 8, 20, and 21. Lash all four wooden box tops together using the four pre-positioned lashings from Figure 2-16, steps 1 through 4. Fit all D-rings and close all load binders according to FM 10-500/TO 13C7-1-5.

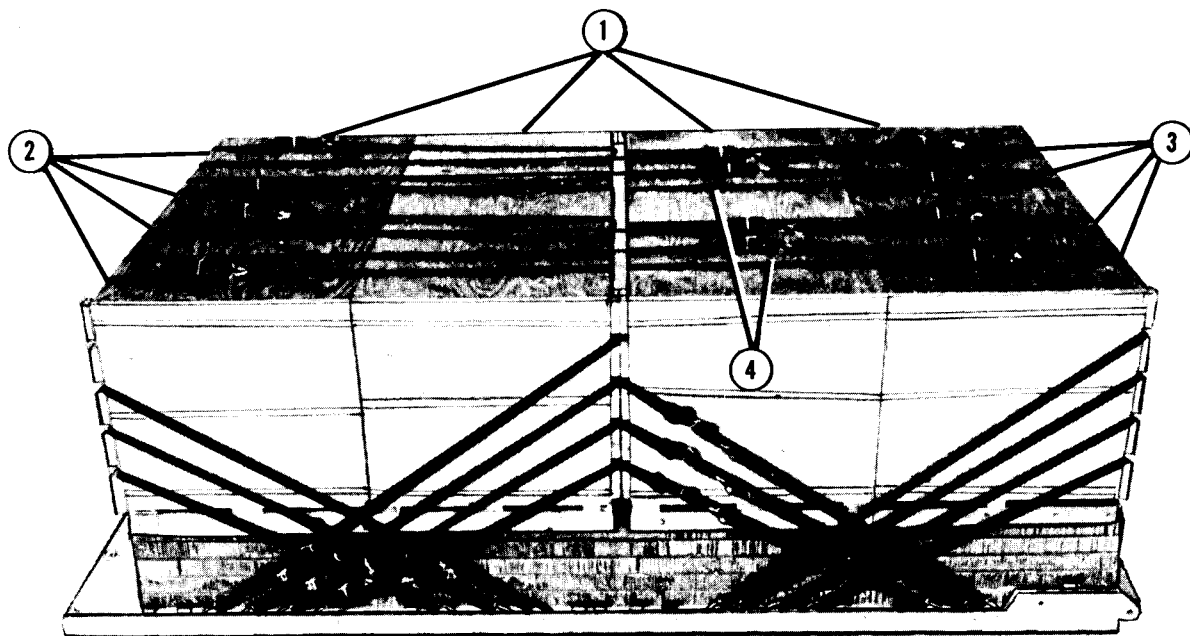

- ① Place all four wooden box tops on the boxes.
- ② Pass the pre-positioned lashings up over the tops of the first and second boxes. Bind the lashings on top of the first box.
- ③ Pass the pre-positioned lashings up over the tops of the third and fourth boxes. Bind the lashings on top of the fourth box.
- ④ Pass the pre-positioned lashings up over the tops of all four boxes. Bind the lashings on top of the third box.

**b. Positioning and Fastening Vertical Lashings.** Position and fasten the vertical lashings as shown in Figure 2-18. Use eight 32-foot lengths of type X nylon webbing, 16 D-rings, and 8 load binders. Fit all D-rings and close all load binders according to FM 10-500/TO 13C7-1-5.

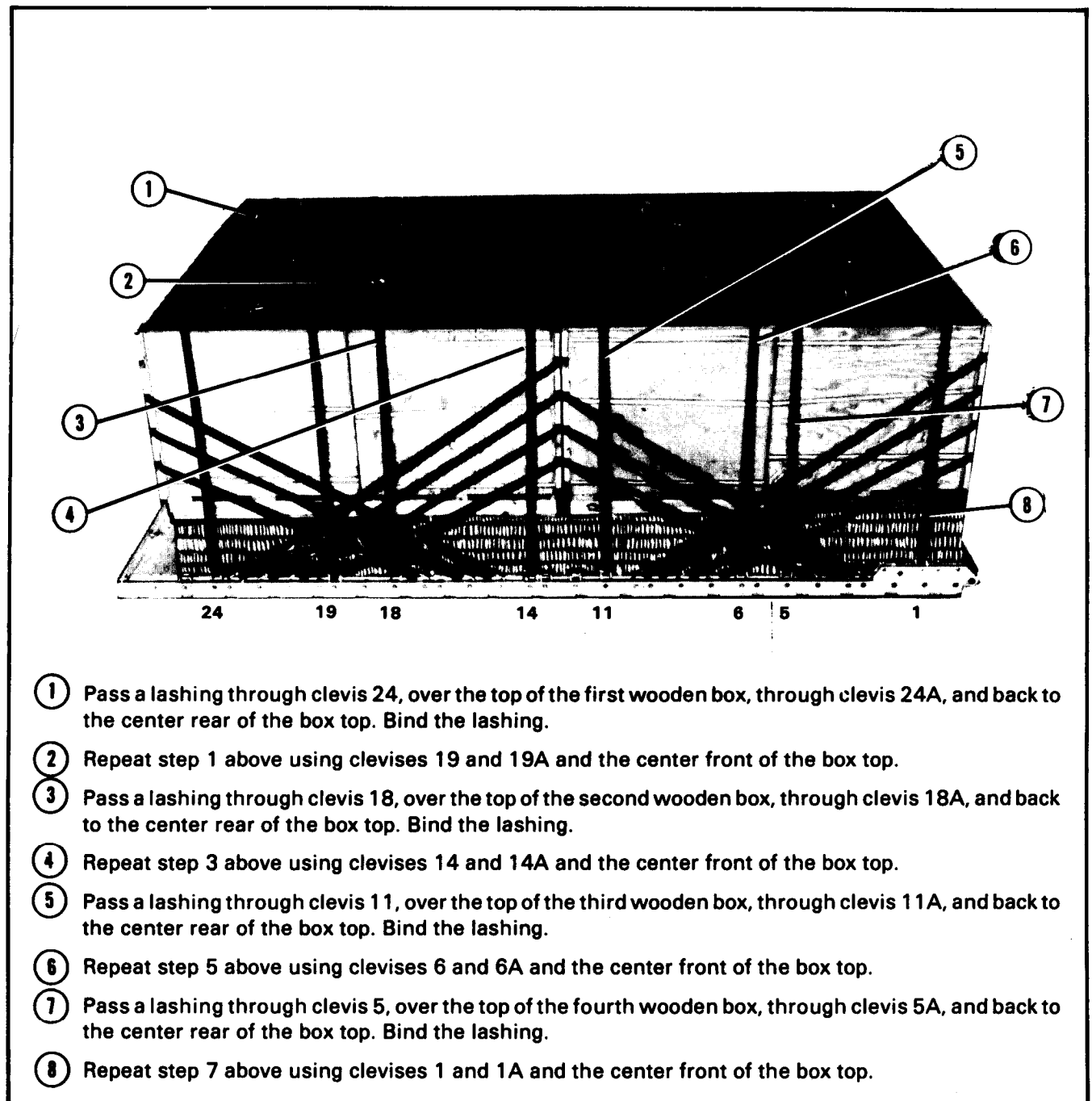

*Figure 2-18. Vertical lashings positioned and fastened*

### 2-22. Installing Attitude Control Bar

Install the attitude control bar using six 16-foot and four 32-foot lengths of type X nylon webbing, 20 D-rings, and 10 load binders as shown in Figure 2-19. Fit all D-rings and close all load binders according to FM 10-500/TO 13C7-1-5.

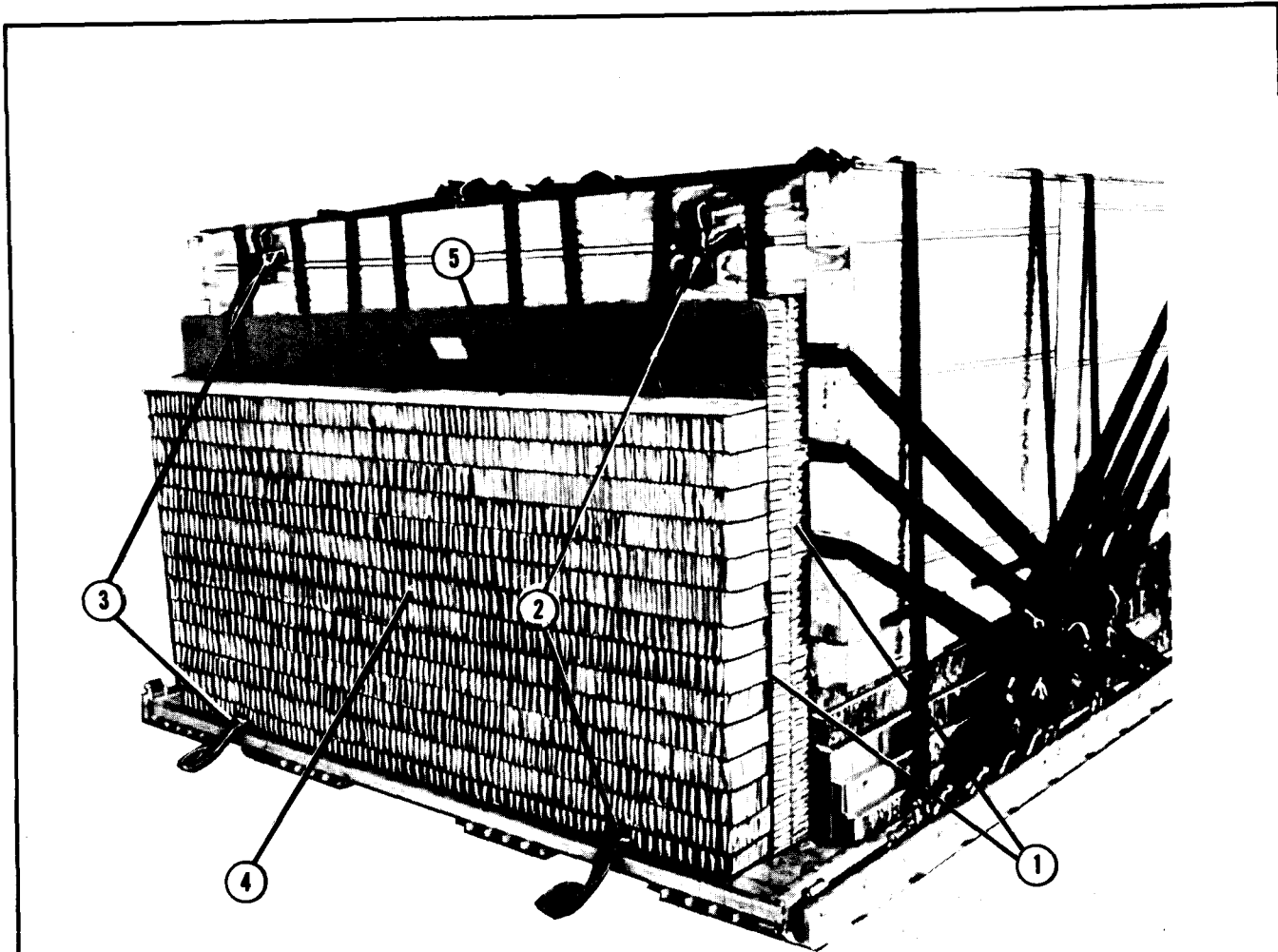

- ① Use two 36- by 88-inch and two 14- by 88-inch pieces of honeycomb to form two 50- by 88-inch honeycomb layers. Position the layers flush against the rear of the first box.
- ② Pass a 16-foot lashing through tiedown ring A8. Fold one end of the lashing, and tape it toward the top of the first box. Roll the remaining end, and lay it at the rear of the platform.
- ③ Repeat step 2 above using tiedown ring D8.
- ④ Stack 14 pieces of 6- by 88-inch honeycomb flush against the items placed in steps 1, 2, and 3 above.
- ⑤ Place a piece of 3/4- by 6- by 88-inch plywood on top of the honeycomb stacked in step 4 above.

*Figure 2-19. Attitude control bar installed*

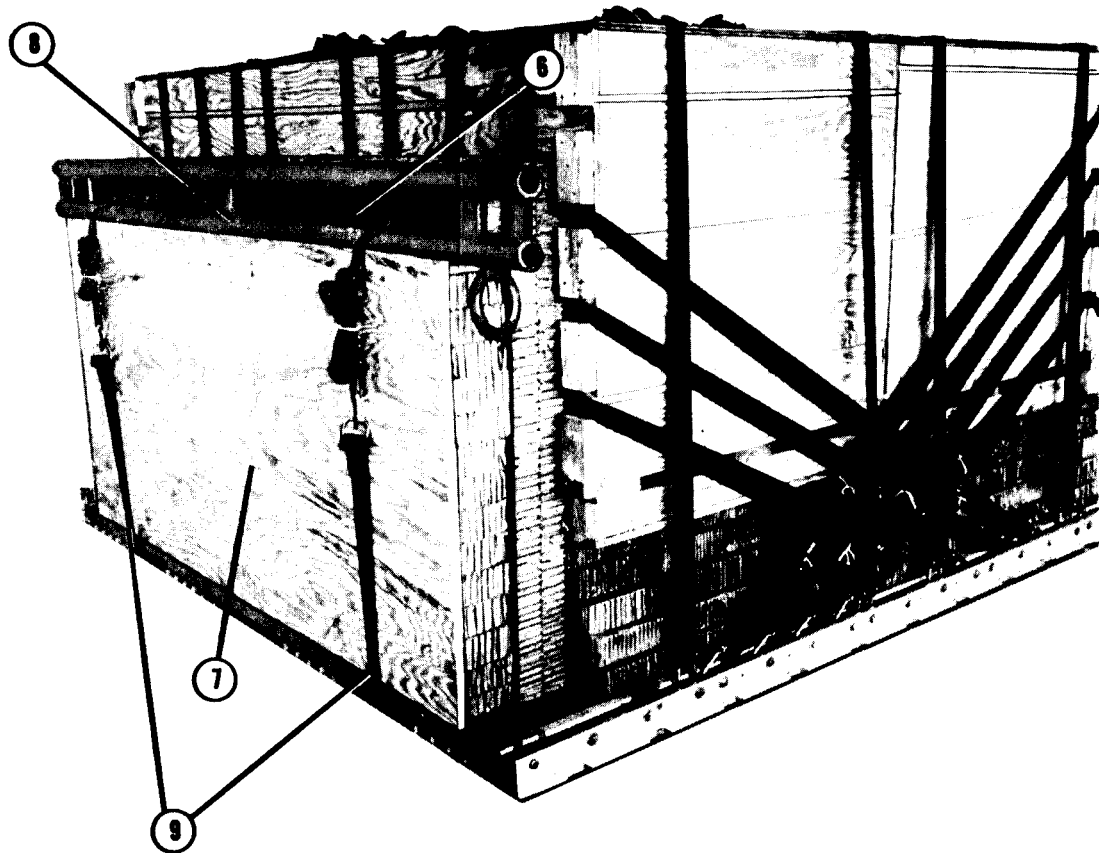

- ⑥ Place a piece of 8- by 88-inch honeycomb on top of the plywood placed in step 5 between the 16-foot lashings and the outer layer of 50-by 88-inch honeycomb.
- ⑦ Place a piece of 3/4- by 42- by 88-inch plywood flush against the honeycomb stacked in step 4.
- ⑧ Position the attitude control bar, with rings down, on top of the plywood placed in step 5 and flush against the honeycomb placed in step 6 above.
- ⑨ Remove the tape from the lashings positioned in steps 2 and 3. Pass the 16-foot lashings between the top and bottom bars of the attitude control bar. Bind the lashings.

*Figure 2-19. Attitude control bar installed (continued)*

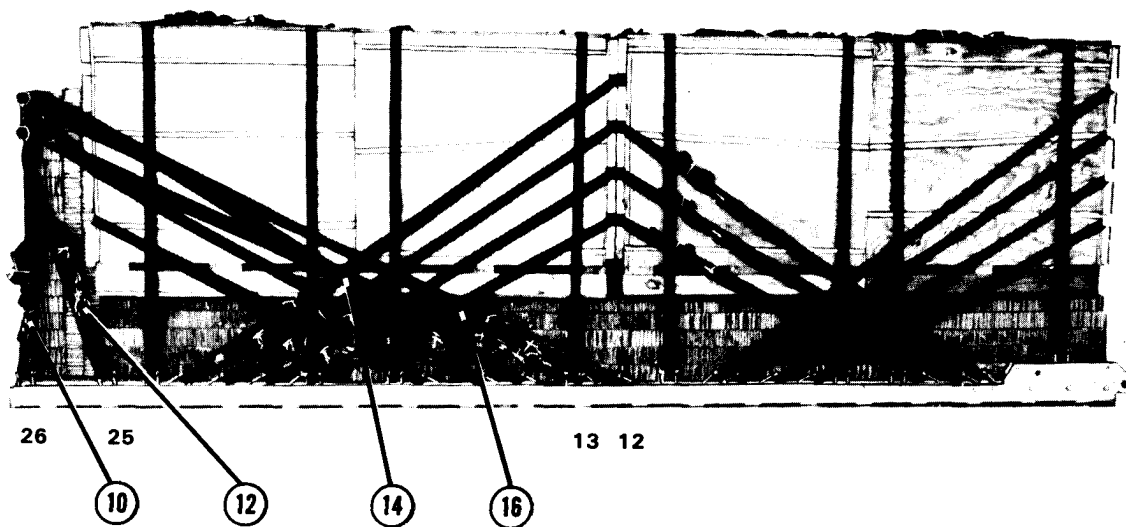

- ⑩ Pass a 16-foot lashing through clevis 26 and the closest ring on the attitude control bar. Bind the lashing.
- ⑪ Repeat step 10 above on the left side of the platform using clevis 26A (not shown).
- ⑫ Repeat step 10 above using clevis 25.
- ⑬ Repeat step 10 above on the left side of the platform using clevis 25A (not shown).
- ⑭ Pass a 32-foot lashing through clevis 13 and around the right lower bar of the attitude control bar. Bind the lashing.
- ⑮ Repeat step 14 above on the left side of the platform using clevis 13A (not shown).
- ⑯ Repeat step 14 above using clevis 12 and the right upper bar.
- ⑰ Repeat step 14 above on the left side of the platform using clevis 12A and the upper bar (not shown).

*Figure 2-19. Attitude control bar installed (continued)*

### 2-23. Installing Extraction System

Install the extraction system according to FM 10-500/TO 13C7-1-5 and as shown in Figure 2-20.

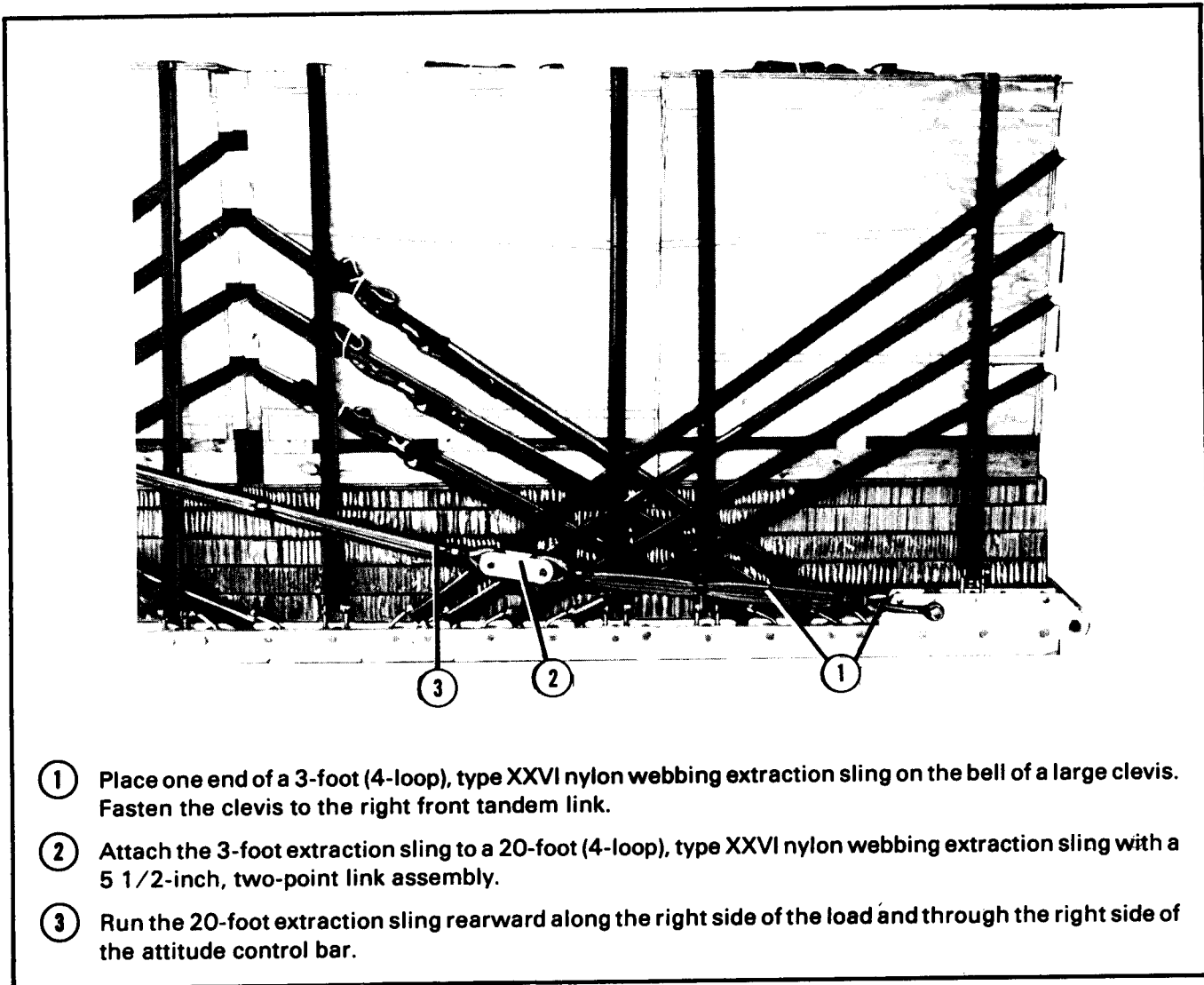

- ① Place one end of a 3-foot (4-loop), type XXVI nylon webbing extraction sling on the bell of a large clevis. Fasten the clevis to the right front tandem link.
- ② Attach the 3-foot extraction sling to a 20-foot (4-loop), type XXVI nylon webbing extraction sling with a 5 1/2-inch, two-point link assembly.
- ③ Run the 20-foot extraction sling rearward along the right side of the load and through the right side of the attitude control bar.

*Figure 2-20. Extraction system installed*

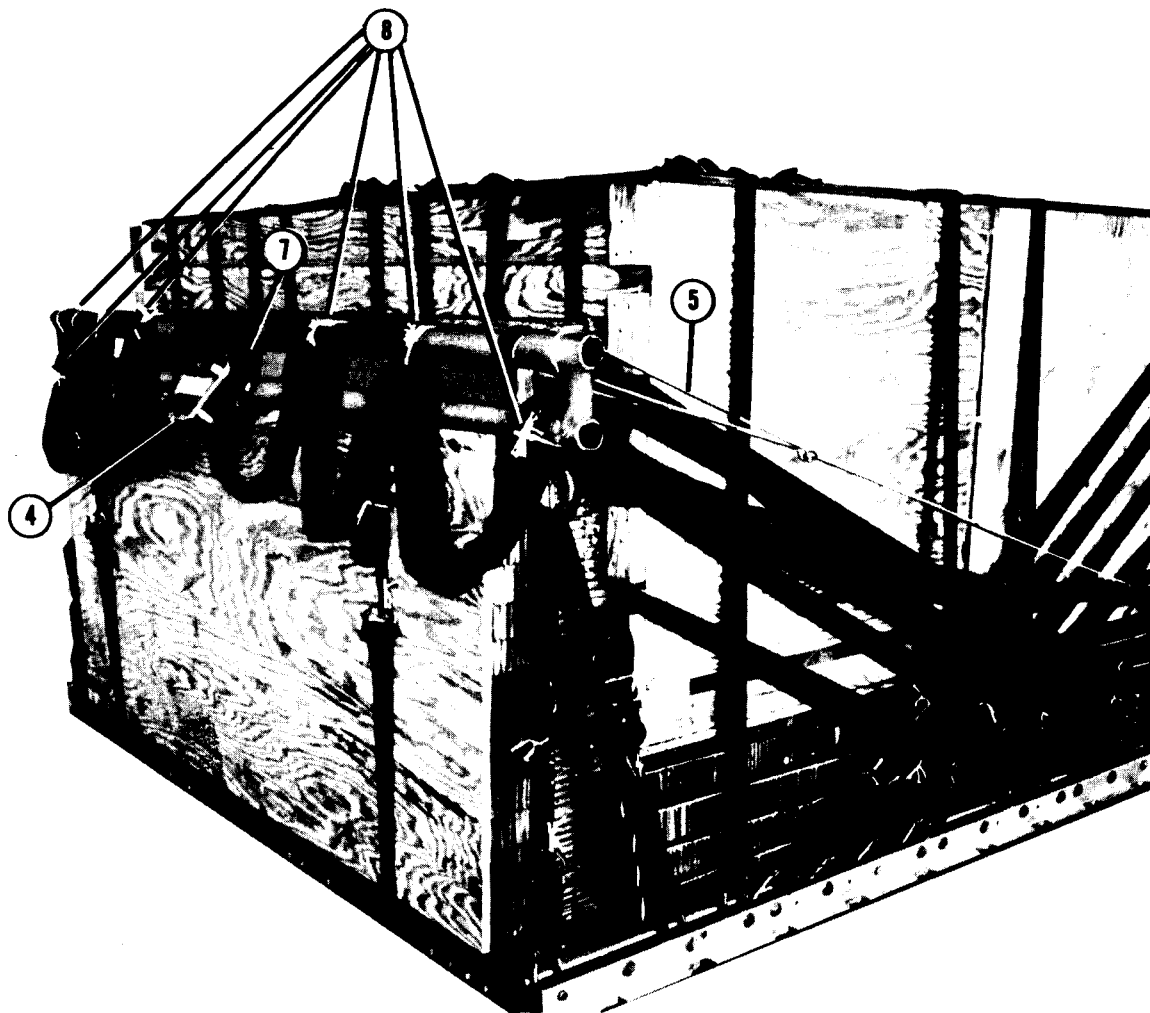

- ④ Attach the extraction sling to a four-point link assembly at the rear of the load.
- ⑤ Tie the extraction sling to the upper bar of the attitude control bar using one length of type III nylon cord.
- ⑥ Repeat steps 1 through 5 on the left side of the load (not shown).
- ⑦ Tie the four-point link assembly to the center brace of the attitude control bar with 1-inch tubular nylon webbing.
- ⑧ Fold and tie the extraction slings to the attitude control bar with six ties. Make each tie with five lengths of 80-pound cotton webbing.

*Figure 2-20. Extraction system installed (continued)*

**2-24. Placing Extraction Parachutes**

Place a 15-foot cargo extraction parachute with a 60-foot (1-loop), type XXVI nylon webbing extraction line and a 28-foot cargo extraction parachute (packed for LAPE) with a 60-foot (3-loop), type XXVI nylon webbing extraction line on the load for installation in the aircraft according to FM 10-500/TO 13C7-1-5.

**2-25. Marking Rigged Load**

Mark the rigged load according to FM 10-500/TO 13C7-1-5 and as shown in Figure 2-21. If the load varies from the one shown in Figure 2-21, the height, weight, CB, and parachute requirements must be recomputed.

**NOTES:**

1. Use a deployment line bag.
2. Lay a 12- by 12-inch piece of felt or honeycomb on the platform to pad the coupling link assembly in the aircraft.

**CAUTION**

Make the final rigger inspection required by FM 10-500/TO 13C7-1-5 before the load leaves the rigging site.

**DATA TAG**



**RIGGED LOAD DATA**

Weight:	Load shown .....	7,480 pounds
	Maximum allowed .....	7,780 pounds
Height .....		65 inches
Width .....		108 inches
Length .....		204 inches
CB (from front edge of platform).....		100 inches

*Figure 2-21. Whole blood rigged for LAPE airdrop on a type V airdrop platform*



**2-26. Equipment Required**

Use the equipment listed in Table 2-2 to rig this load.

*Table 2-2. Equipment required for rigging whole blood for LAPE airdrop on a type V platform*

National Stock Number	Quantity	Item
8040-00-273-8713	Adhesive, paste, 1-gal	As required
1670-00-003-4389	Bar, attitude control	1
3990-00-937-0272	Binder, load, 10,000-lb	44
1670-01-035-6054	Bridle, extraction line bag, use w extraction line leaf	1
4030-00-090-5354	Clevis, suspension, 1-in (large)	2
4020-00-240-2146	Cord, nylon, type III, 550-lb	As required
8135-00-664-6958	Cushioning material, packaging, cellulose wadding	As required
5365-00-937-0147	D-ring, heavy-duty, 10,000-lb	88
8305-00-958-3685	Felt, 1/2-in thick	As required
1670-01-183-2678	Leaf, extraction line (line bag)	2
	Line, extraction, type XXVI nylon webbing:	
1670-01-064-4452	60-ft (1-loop)	1
1670-01-062-6313	60-ft (3-loop)	1
	Link assembly:	
1670-01-072-1378	Extraction (LAPE)	1
1670-00-006-2752	Four-point	1
	Two-point:	3
5306-00-435-8994	Bolt, 1-in diam, 4-in long	(6)
5310-00-232-5165	Nut, 1-in	(6)
1670-00-003-1954	Plate, side, 5 1/2-in	(6)
5365-00-007-3414	Spacer, large	(6)
1670-00-783-5988	Type IV	1
5510-00-220-6146	Lumber, 2- by 4-in:	
	6-in	32
	7 1/2-in	8
	42-in	8
	86-in	8
	95 1/2-in	12
5510-00-220-6274	Lumber, 4- by 4- by 43 1/2-in	20
	Nail, steel wire, common:	
5315-00-162-3151	4d	As required
5315-00-010-4657	6d	As required
5315-00-010-4659	8d	As required
5315-00-010-4661	10d	As required
1670-00-753-3928	Pad, energy-dissipating, honeycomb,	
	3- by 36- by 96-in:	26 sheets
	2- by 94-in	(80)
	4- by 90-in	(6)
	6- by 88-in	(14)
	6- by 90-in	(6)
	6- by 94-in	(8)
	8- by 7 1/2-in	(3)

Table 2-2. Equipment required for rigging whole blood for LAPE airdrop on a type V platform (continued)

National Stock Number	Quantity	Item
	8- by 84 1/2-in	(3)
	8- by 88-in	(1)
	10- by 90-in	(6)
	12- by 12-in	(1)
	12- by 90-in	(6)
	14- by 88-in	(2)
	36- by 88-in	(2)
	36- by 94-in	(8)
	91 1/2- by 8-in	(3)
	Parachute, cargo extraction:	
1670-00-052-1548	15-ft <u>or</u>	1
1670-01-063-3715	15-ft	1
1670-00-262-1797	28-ft (packed for LAPE) <u>or</u>	1
1670-00-040-8135	28-ft, heavy-duty (packed for LAPE)	1
	Platform, airdrop, type V, 16-ft:	1
1670-01-162-2385	Bumper, nose	(1)
1670-01-162-2372	Clevis, load tiedown	(52)
1670-01-162-2381	Tandem link	(2)
5530-00-128-4981	Plywood, 3/4-in:	
	6- by 88-in	1
	39 1/2- by 42-in	8
	39 1/2- by 95 1/2-in	8
	42- by 88-in	1
	42- by 94-in	4
	43 1/2- by 95 1/2-in	8
	Sling, cargo, airdrop:	
	For extraction:	
1670-01-062-6306	3-ft (4-loop), type XXVI nylon webbing	2
1670-01-064-4453	20-ft (4-loop), type XXVI nylon webbing	2
8135-00-283-0667	Strapping, steel, 5/8-in	As required
7510-00-266-5016	Tape, adhesive, 2-in	As required
	Webbing:	
8305-00-268-2411	Cotton, 80-lb	As required
8305-00-082-5752	Nylon, tubular, 1/2-in, 1,000-lb, natural	As required
8305-00-268-2455	Nylon, tubular, 1-in, 4,000-lb, olive drab	As required
8305-00-263-3591	Nylon, type VIII, 3,600-lb	As required
8305-00-261-8584	Nylon, type X, treated, 8,700-lb, olive drab	As required

## CHAPTER 3

## RIGGING WHOLE BLOOD ON A 24-FOOT, TYPE V AIRDROP PLATFORM FOR LAPE AIRDROP

### 3-1. Description of Load

Whole blood is rigged on a 24-foot, type V airdrop platform with one 28-foot extraction parachute (packed for LAPE) and one 15-foot extraction parachute (drogue) for C-130 aircraft.

### 3-2. Preparing Platform

Prepare a 24-foot, type V airdrop platform as described below.

#### a. Assembling and Inspecting Platform.

Inspect, or assemble and inspect, the platform as outlined in TM 10-1670-268-20&P/TO 13C7-52-22.

**b. Installing Tandem Links.** Install a tandem link on the front of each rail as shown in Figure 3-1.

**c. Attaching and Numbering Clevises.** Bolt 74 tiedown clevises to the side rail bushings and tandem links according to TM 10-1670-268-20&P/TO 13C7-52-22 and as shown in Figure 3-1. Number the clevises as shown in Figure 3-1.

**NOTE:** The nose bumper must be installed.

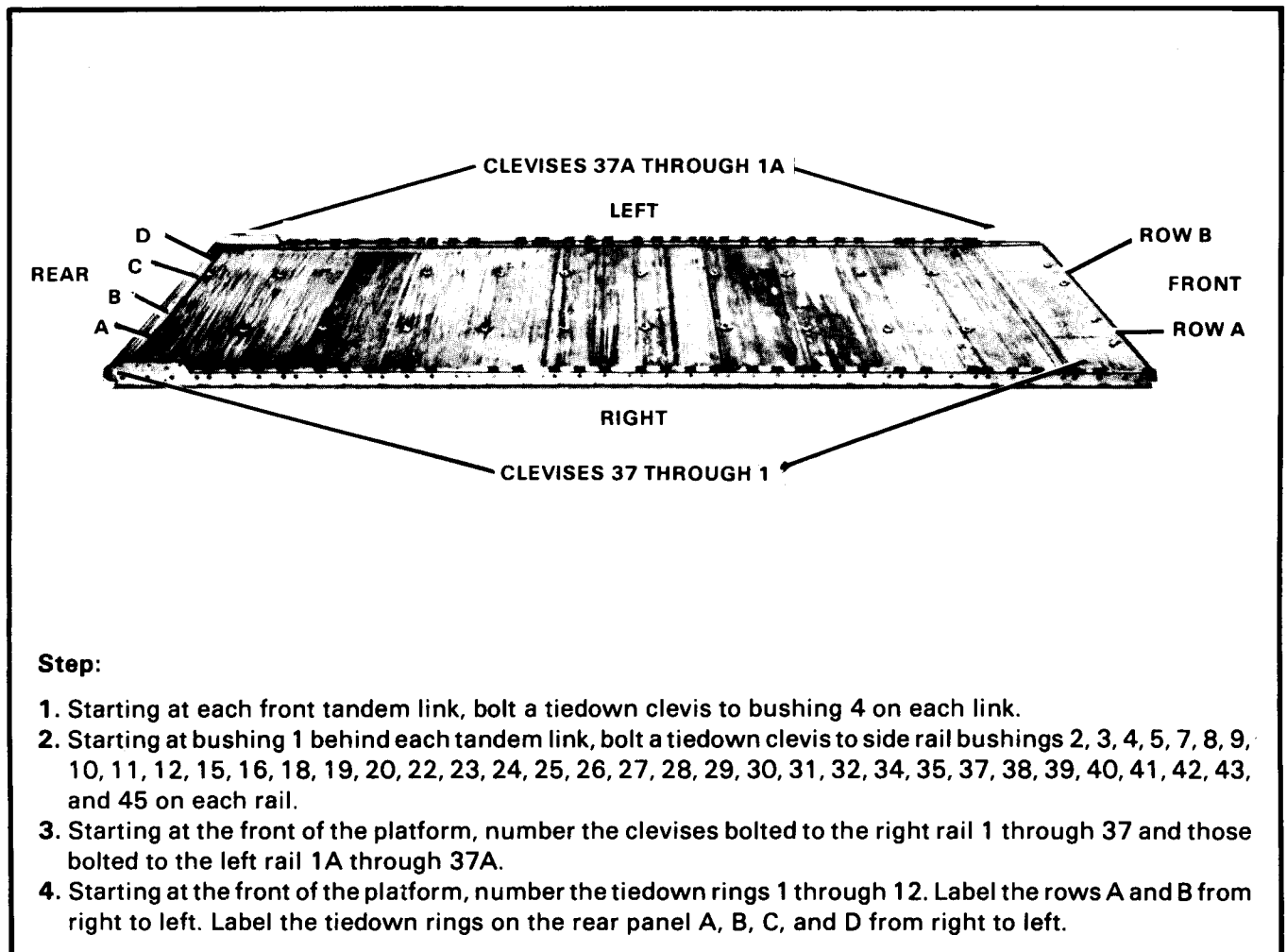
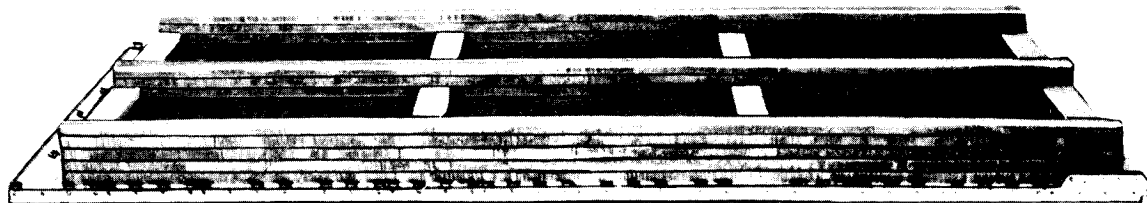

Figure 3-1. Platform prepared

### 3-3. Preparing and Placing Honeycomb Layers

Prepare and place the honeycomb layers as shown in Figures 3-2 and 3-3.

**NOTE: Glue all honeycomb layers together. Do not glue the layers to the platform.**



Layer Number	Pieces	Width (Inches)	Length (Inches)	Material	Instructions
1	12	12	68	Honeycomb	Lay four pieces of honeycomb end to end forming a 272-inch row. Prepare three more 272-inch rows. Lay each row 29 3/4 inches apart and 13 inches from the rear edge of the platform. Outside rows are 2 3/4 inches from the side rails.
2	12	10	68	Honeycomb	Center four pieces of honeycomb end to end on top of each row in layer 1.
3	4	91 1/2	8	Honeycomb	Use honeycomb as bridges. Lay one piece across layer 2 flush with front edge of the honeycomb. Lay the second piece across layer 2, 88 inches from front edge of the honeycomb. Lay the third piece across layer 2, 88 inches from rear edge of the honeycomb. Lay the fourth piece flush with rear edge of the honeycomb.
	9	8	80	Honeycomb	Use honeycomb as fillers between the bridges.
4	12	6	68	Honeycomb	Center four pieces of honeycomb end to end on top of each 272-inch row in layer 3.
5	12	4	68	Honeycomb	Center four pieces of honeycomb end to end on top of each row in layer 4.

*Figure 3-2. Honeycomb layers prepared and placed on platform*

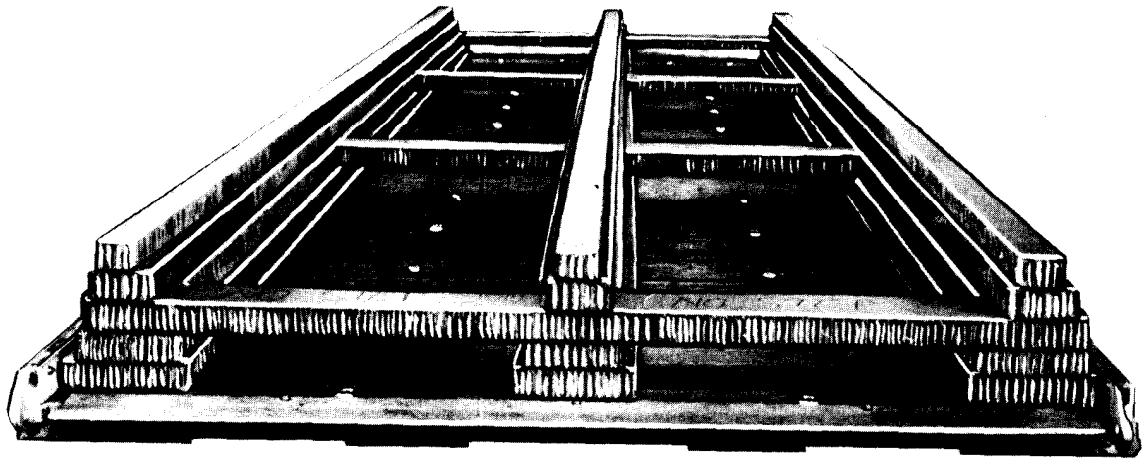

**FRONT**

*Figure 3-3. Front view of honeycomb layers placed on platform*

### 3-4. Preparing Wooden Boxes

Prepare six wooden boxes as described in paragraph 2-4.

### 3-5. Positioning and Lashing Wooden Boxes

Position and lash six wooden boxes on the honeycomb as shown in Figure 3-4. Lash the boxes using twenty-five 48-foot lengths of type X nylon webbing, twelve 16-foot lengths of type X nylon webbing, 74 D-rings, and 37 load binders. Position four 48-foot lashings to be used later for securing the wooden box tops. Position the remaining 21

lashings, and fasten them immediately after they have been positioned on each pair of boxes. Position the twelve 16-foot lashings to be used later for securing the wooden box tops in pairs. Fit all D-rings and close all load binders according to FM 10-500/TO 13C7-1-5.

**CAUTION**

Positioning of the load binders is critical. Place the load binders exactly where shown.

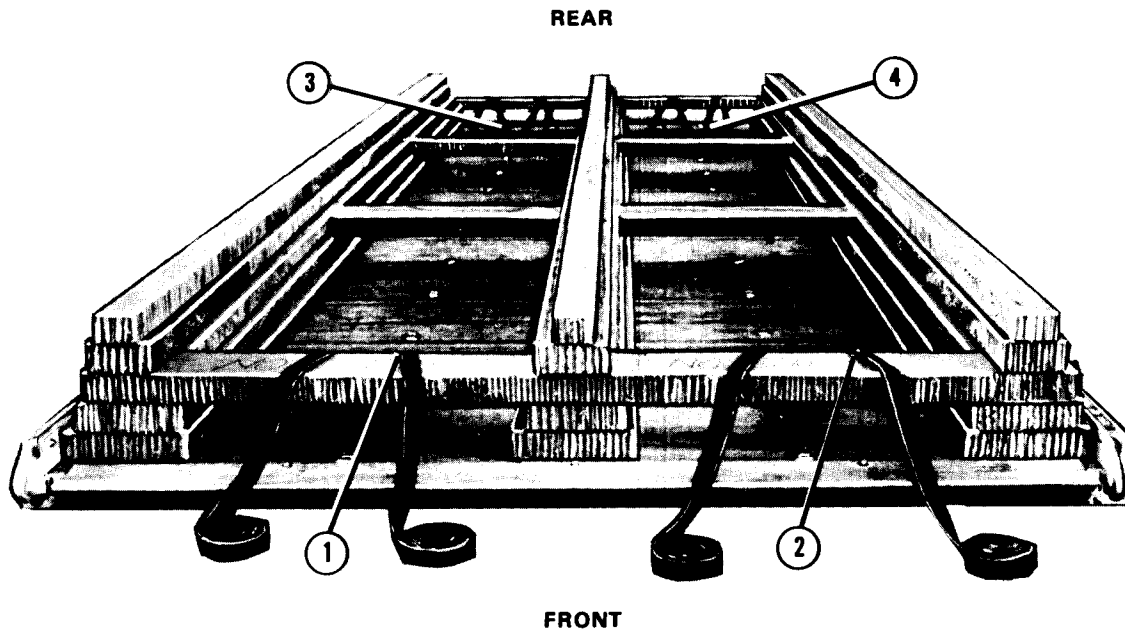

- ① Pass one 48-foot lashing through tiedown ring A2. Bring the ends of the lashing over the top of the front bridge to the front of the platform, and roll them. (This pre-positioned lashing will be used to lash all six wooden box tops together.)
- ② Repeat step 1 above using tiedown ring B2. (This pre-positioned lashing will be used to lash all six wooden box tops together.)
- ③ Pass one 48-foot lashing through tiedown ring A11. Bring the ends of the lashing over the top of the rear bridge to the rear of the platform, and roll them. (This pre-positioned lashing will be used to lash all six wooden box tops together.)
- ④ Repeat step 3 above using tiedown ring B11. (This pre-positioned lashing will be used to lash all six wooden box tops together.)

Figure 3-4. Wooden boxes positioned and lashed

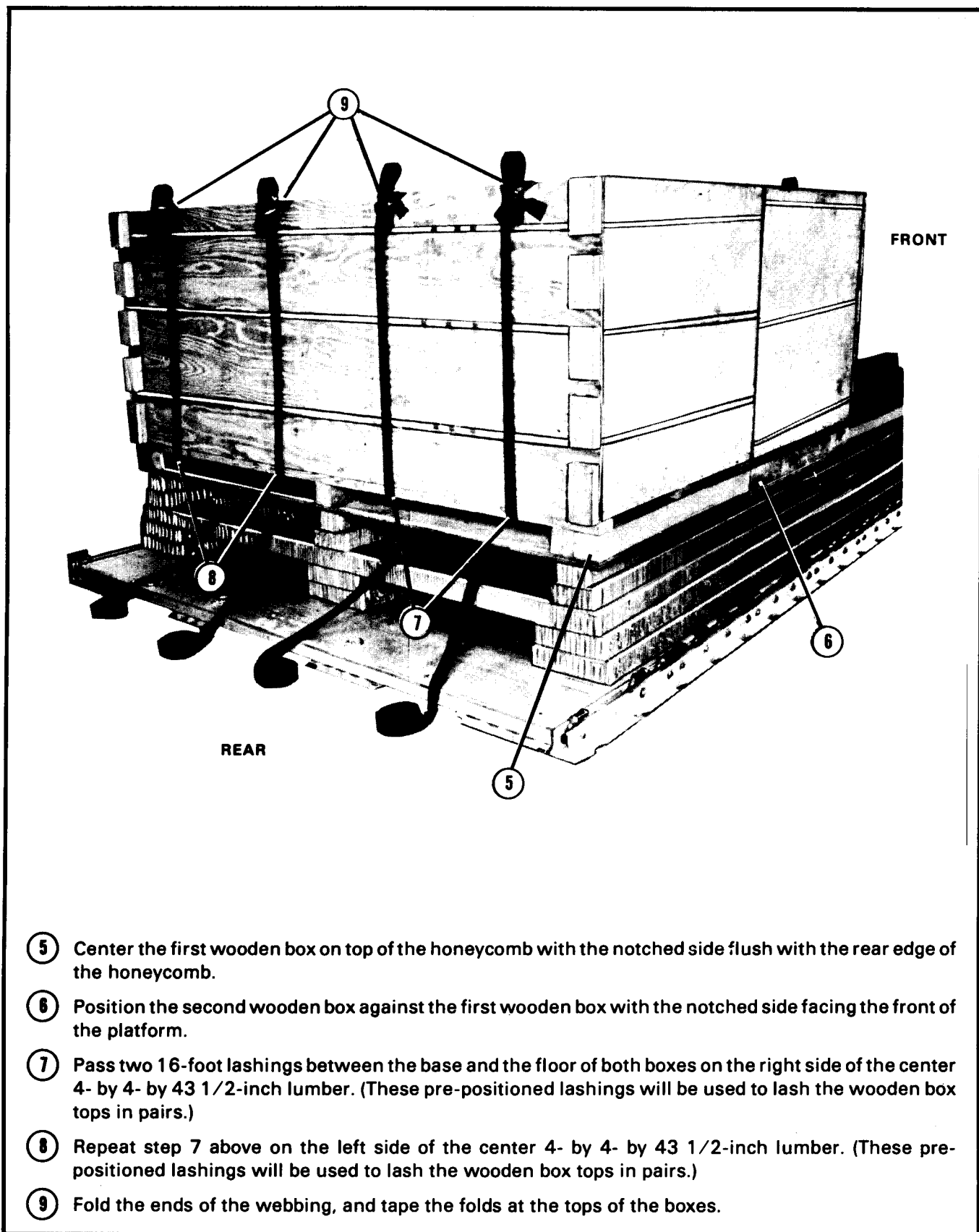

- ⑤ Center the first wooden box on top of the honeycomb with the notched side flush with the rear edge of the honeycomb.
- ⑥ Position the second wooden box against the first wooden box with the notched side facing the front of the platform.
- ⑦ Pass two 16-foot lashings between the base and the floor of both boxes on the right side of the center 4- by 4- by 43 1/2-inch lumber. (These pre-positioned lashings will be used to lash the wooden box tops in pairs.)
- ⑧ Repeat step 7 above on the left side of the center 4- by 4- by 43 1/2-inch lumber. (These pre-positioned lashings will be used to lash the wooden box tops in pairs.)
- ⑨ Fold the ends of the webbing, and tape the folds at the tops of the boxes.

*Figure 3-4. Wooden boxes positioned and lashed (continued)*

**NOTE: Lash the boxes in pairs.**

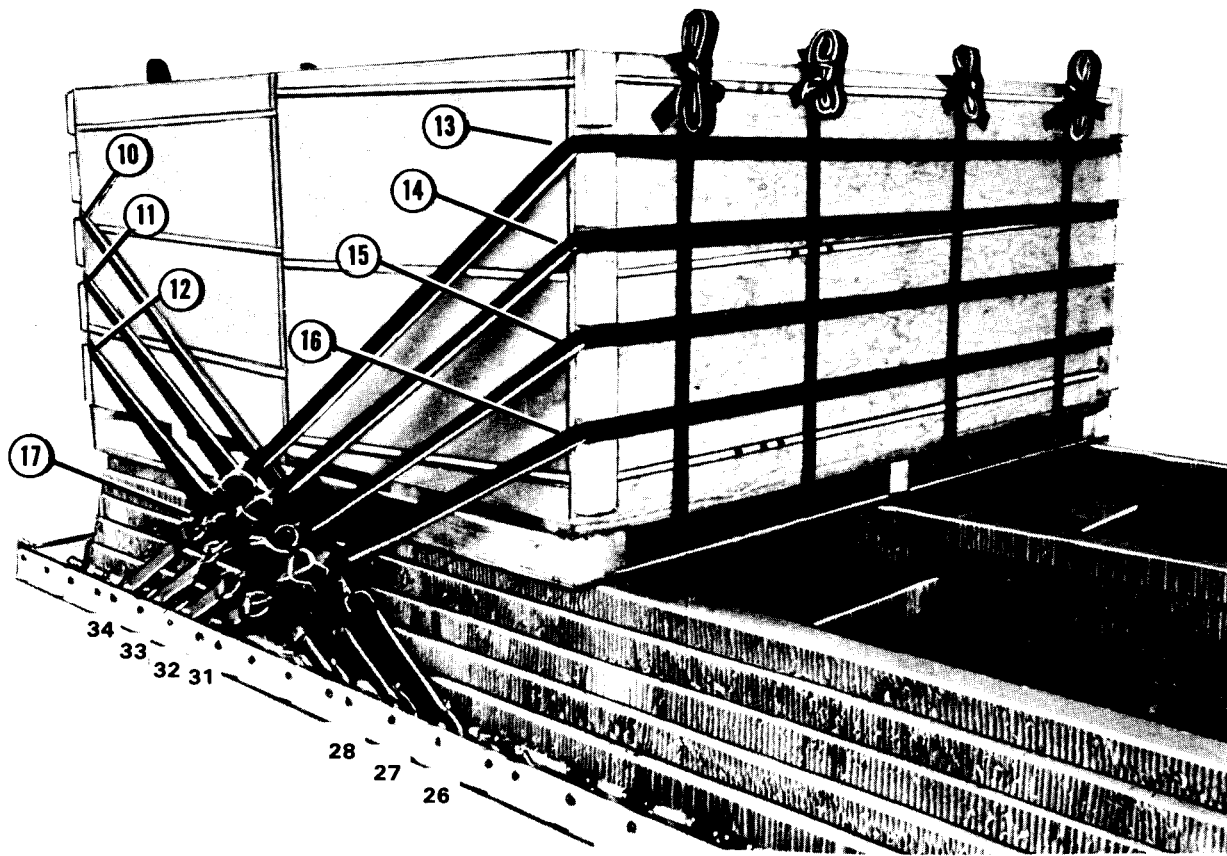

- ⑩ Pass a lashing through clevis 26, through the second notch from the top on both sides of the first box, through clevis 26A, and back to the right side of the platform.
- ⑪ Repeat step 10 above using clevises 27 and 27A and the third notch from the top.
- ⑫ Repeat step 10 above using clevises 28 and 28A and the bottom notch.
- ⑬ Pass a lashing through clevis 34, through the top notch on both sides of the second box, through clevis 34A, and back to the right side of the platform.
- ⑭ Repeat step 13 above using clevises 33 and 33A and the second notch from the top.
- ⑮ Repeat step 13 above using clevises 32 and 32A and the third notch from the top.
- ⑯ Repeat step 13 above using clevises 31 and 31A and the bottom notch.
- ⑰ Bind lashings placed in steps 10 through 16 above.

*Figure 3-4. Wooden boxes positioned and lashed (continued)*



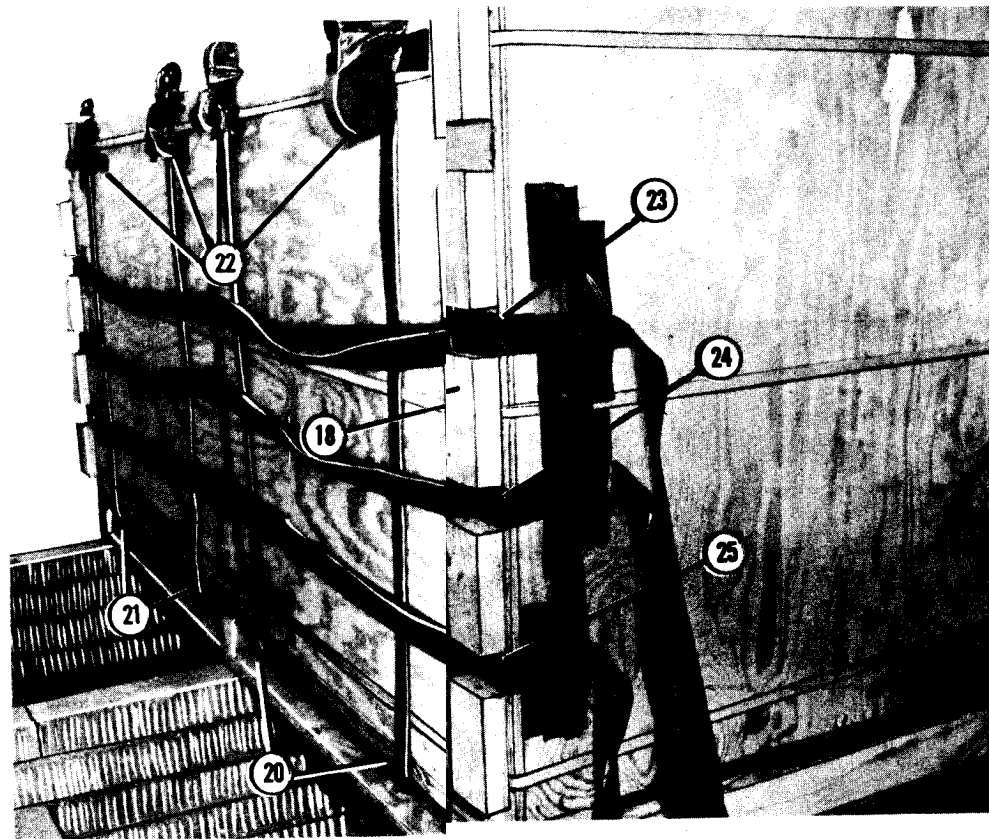

- ⑱ Position the third wooden box on top of the honeycomb with the notched side 24 inches from the front of the second box.
  - ⑲ Position the fourth wooden box against the third box with the notched side facing the front of the platform (not shown).
  - ⑳ Pass two 16-foot lashings between the base and the floor of both boxes on the right side of the center 4- by 4- by 43 1/2-inch lumber. (These pre-positioned lashings will be used to lash the wooden box tops in pairs.)
  - ㉑ Repeat step 20 above on the left side of the center 4- by 4- by 43 1/2-inch lumber. (These pre-positioned lashings will be used to lash the wooden box tops in pairs.)
  - ㉒ Fold the ends of the webbing, and tape the folds at the tops of the boxes.
  - ㉓ Pass a lashing through clevis 13, through the second notch from the top on both sides of the third box, through clevis 13A, and back to the right side of the platform. Tape the lashing to the side of the box.
- NOTE: Tape on the rear of the box is used as a rigging aid. It may or may not be removed.**
- ㉔ Repeat step 23 above using clevises 14 and 14A and the third notch from the top.
  - ㉕ Repeat step 23 above using clevises 15 and 15A and the bottom notch.

*Figure 3-4. Wooden boxes positioned and lashed (continued)*

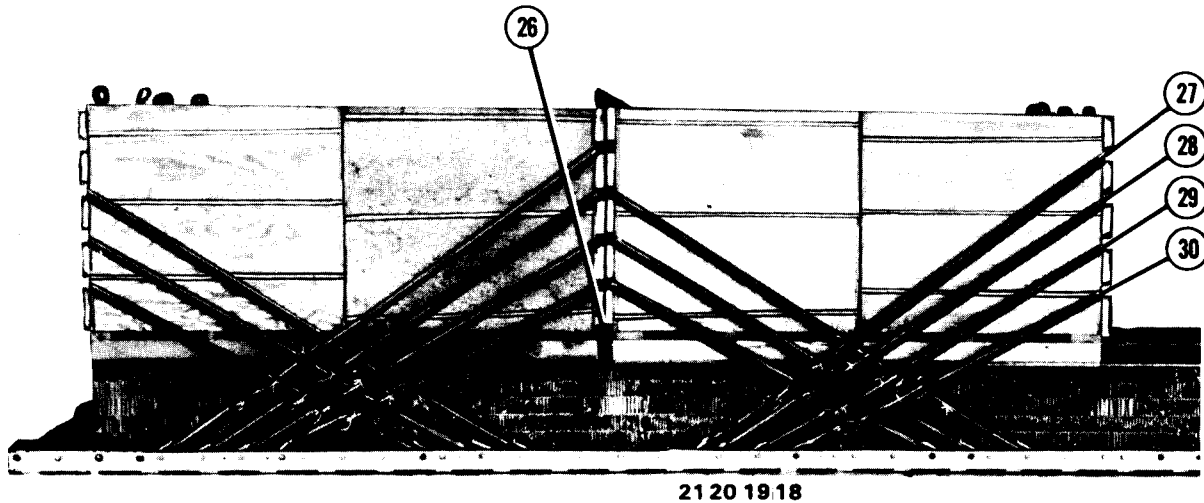

- ②⑥ Push the third and fourth wooden boxes flush against the second box.
- ②⑦ Pass a lashing through clevis 21, through the top notch on both sides of the fourth box, through clevis 21A, and back to the right side of the platform.
- ②⑧ Repeat step 27 above using clevises 20 and 20A and the second notch from the top.
- ②⑨ Repeat step 27 above using clevises 19 and 19A and the third notch from the top.
- ③⑩ Repeat step 27 above using clevises 18 and 18A and the bottom notch.
- ③① Remove the tape from the lashings placed in steps 23, 24, and 25. Bind lashings placed in steps 23, 24, and 25 first; then bind lashings placed in steps 27 through 30 (not shown).

*Figure 3-4. Wooden boxes positioned and lashed (continued)*

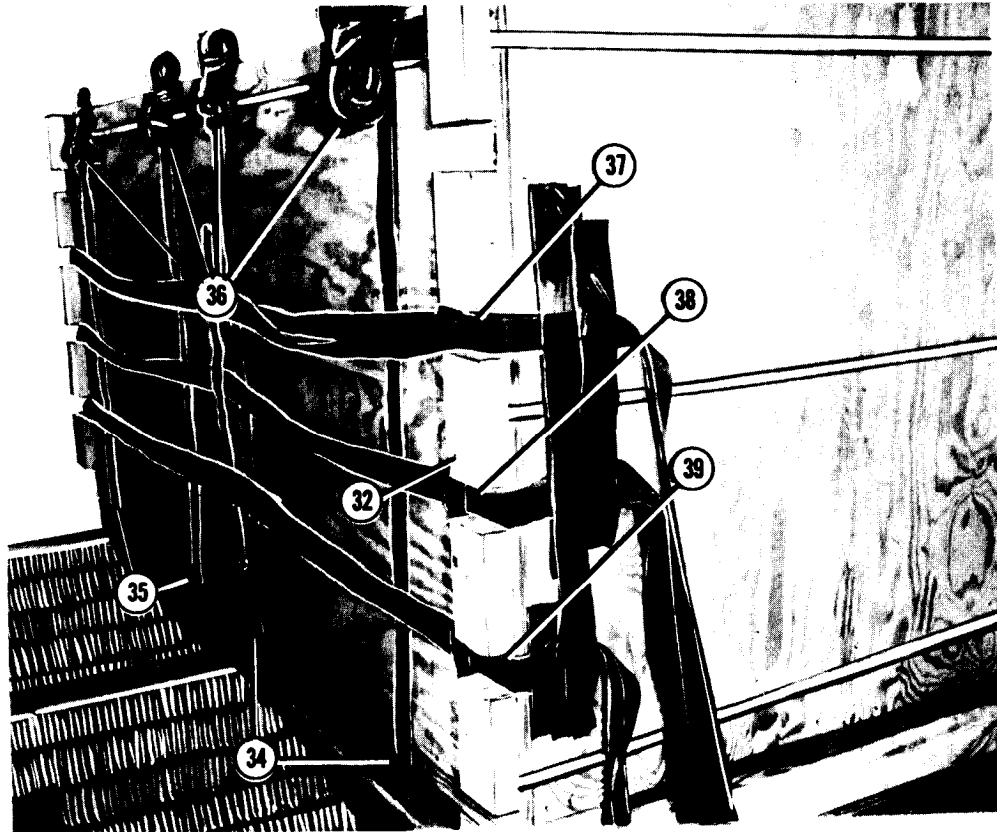

- ③② Position the fifth wooden box on top of the honeycomb with the notched side 24 inches from the front of the fourth box.
- ③③ Position the sixth wooden box against the fifth box with the notched side facing the front of the platform (not shown).
- ③④ Pass two 16-foot lashings between the base and the floor of both boxes on the right side of the center 4- by 4- by 43 1/2-inch lumber. (These pre-positioned lashings will be used to lash the wooden box tops in pairs.)
- ③⑤ Repeat step 34 above on the left side of the center 4- by 4- by 43 1/2-inch lumber. (These pre-positioned lashings will be used to lash the wooden box tops in pairs.)
- ③⑥ Fold the ends of the webbing, and tape the folds at the tops of the boxes.
- ③⑦ Pass a lashing through clevis 2, through the second notch from the top on both sides of the fifth box, through clevis 2A, and back to the right side of the platform. Tape the lashing to the side of the box.
- ③⑧ Repeat step 37 above using clevises 3 and 3A and the third notch from the top.
- ③⑨ Repeat step 37 above using clevises 4 and 4A and the bottom notch.

*Figure 3-4. Wooden boxes positioned and lashed (continued)*

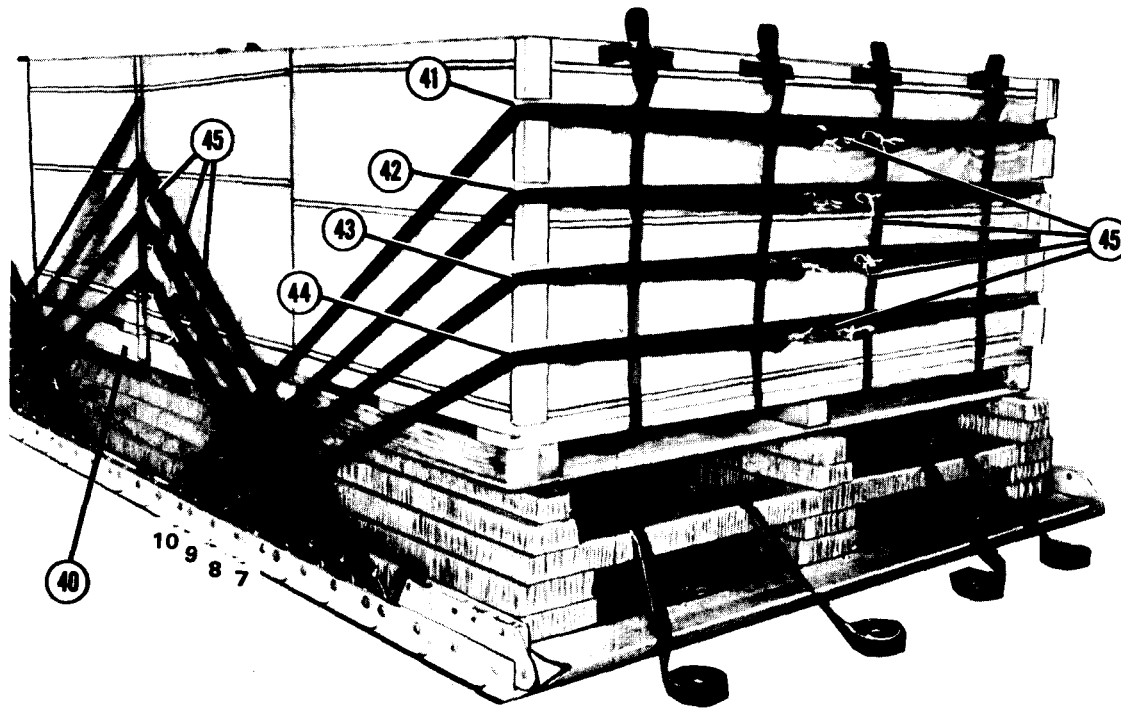

- ④⑩ Push the fifth and sixth wooden boxes flush against the fourth box.
- ④⑪ Pass a lashing through clevis 10, through the top notch on both sides of the sixth box, through clevis 10A, and back to the center front of the box.
- ④⑫ Repeat step 41 above using clevises 9 and 9A and the second notch from the top.
- ④⑬ Repeat step 41 above using clevises 8 and 8A and the third notch from the top.
- ④⑭ Repeat step 41 above using clevises 7 and 7A and the bottom notch.
- ④⑮ Remove the tape from the lashings placed in steps 37, 38, and 39. Bind lashings placed in steps 37, 38, and 39 first; then bind lashings placed in steps 41 through 44.

*Figure 3-4. Wooden boxes positioned and lashed (continued)*

### 3-6. Packing Blood in Cardboard Containers

Pack whole blood in cardboard containers as described in paragraph 2-6. One hundred and twenty containers are required for this load.

### 3-7. Packing Blood Containers in Wooden Boxes

Once the blood containers are delivered to the rigging site, pack them in six wooden boxes as described in paragraph 2-7a and as shown in Figure 2-7.

**a. Positioning and Lashing Wooden Box Tops.** Position and lash the wooden box tops (prepared as shown in Figure 2-4) as shown in Figure 3-5. Lash the wooden box tops in pairs using the 12 pre-positioned lashings from Figure 3-4, steps 7,8,20,21,34, and 35. Lash all six wooden box tops together using the four pre-positioned lashings from Figure 3-4, steps 1 through 4. Fit all D-rings and close all load binders according to FM 10-500/TO 13C7-1-5.

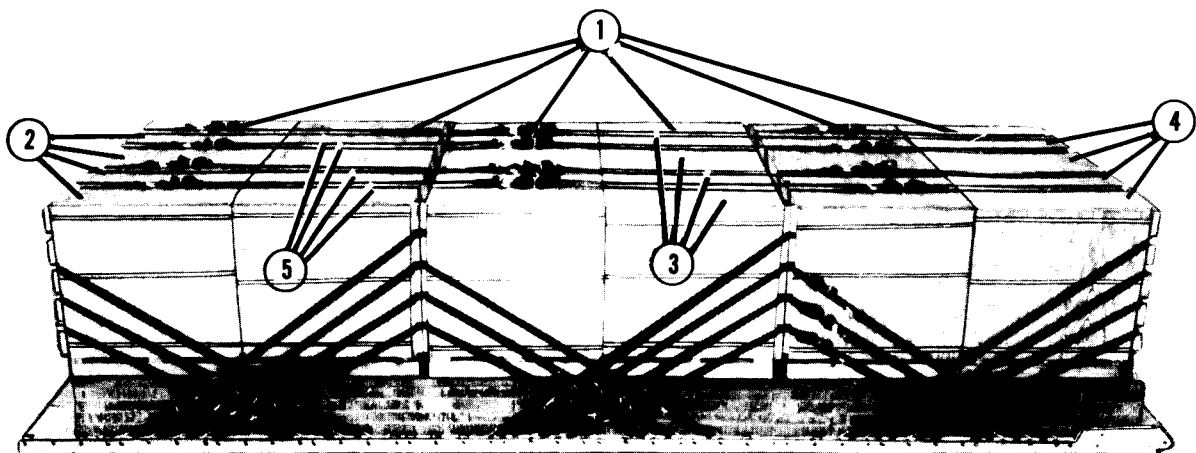

- ① Place all six wooden box tops on the boxes.
- ② Pass the pre-positioned lashings up over the tops of the first and second boxes. Bind the lashings on top of the first box.
- ③ Pass the pre-positioned lashings up over the tops of the third and fourth boxes. Bind the lashings on top of the third box.
- ④ Pass the pre-positioned lashings up over the tops of the fifth and sixth boxes. Bind the lashings on top of the fifth box.
- ⑤ Pass the pre-positioned lashings up over the tops of all six boxes. Bind the lashings on top of the third box.

Figure 3-5. Wooden box tops positioned and lashed

**b. Positioning and Fastening Vertical Lashings.** Position and fasten the vertical lashings as shown in Figure 3-6. Use twelve 32-foot lengths of type X nylon webbing, 24 D-rings, and 12 load binders. Fit all D-rings and close all load binders according to FM 10-500/TO 13C7-1-5.

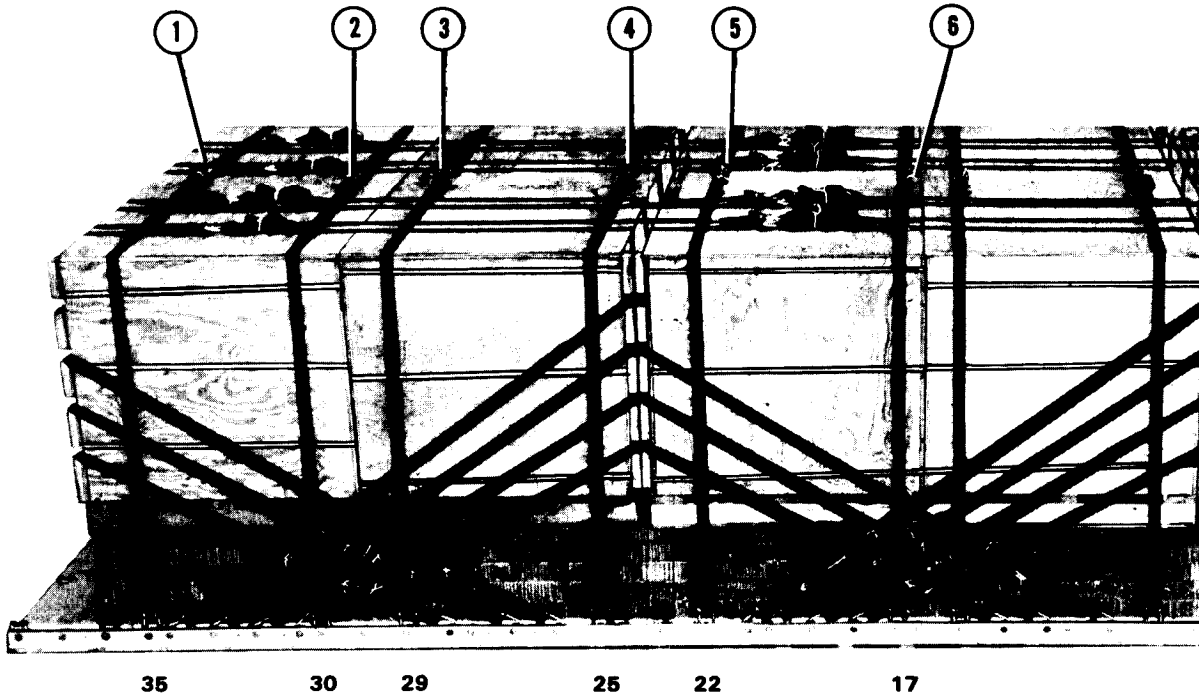

- ① Pass a lashing through clevis 35, over the top of the first wooden box, through clevis 35A, and back to the center rear of the box top. Bind the lashing.
- ② Repeat step 1 above using clevises 30 and 30A and the center front of the first box top.
- ③ Pass a lashing through clevis 29, over the top of the second wooden box, through clevis 29A, and back to the center rear of the box top. Bind the lashing.
- ④ Repeat step 3 above using clevises 25 and 25A and the center front of the second box top.
- ⑤ Pass a lashing through clevis 22, over the top of the third wooden box, through clevis 22A, and back to the center rear of the box top. Bind the lashing.
- ⑥ Repeat step 5 above using clevises 17 and 17A and the center front of the third box top.

*Figure 3-6. Vertical lashings positioned and fastened*

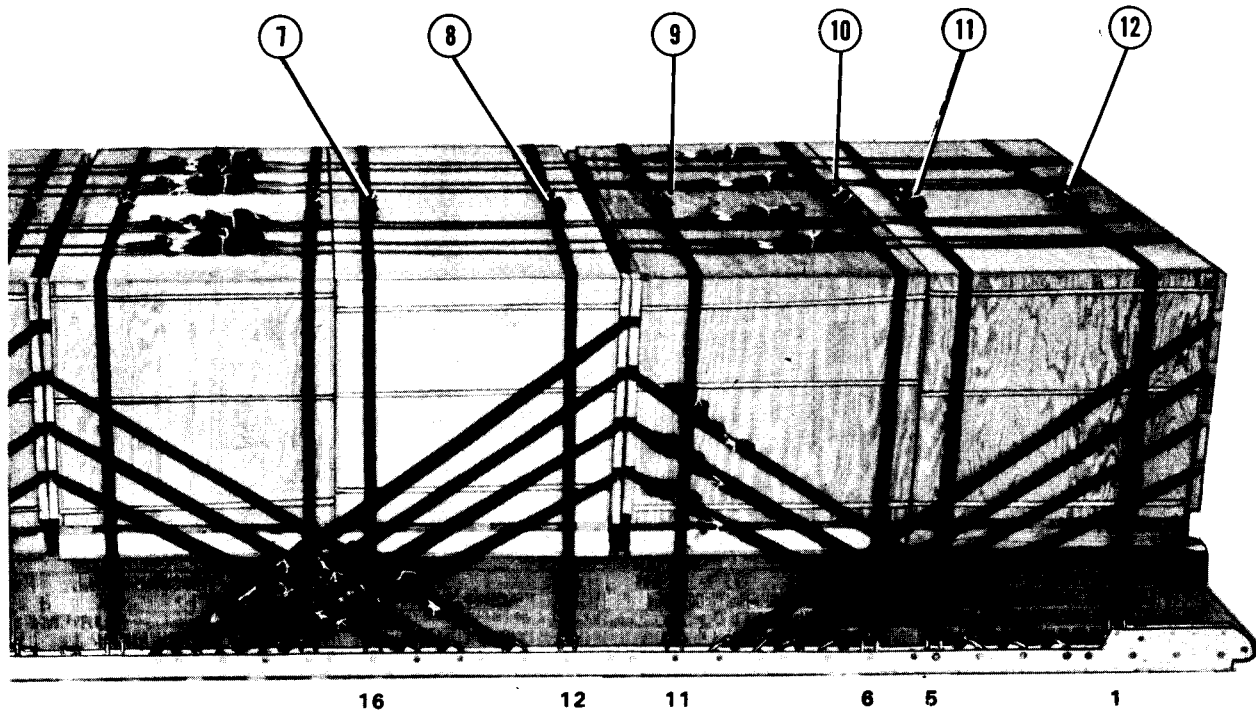

- ⑦ Pass a lashing through clevis 16, over the top of the fourth wooden box, through clevis 16A, and back to the center rear of the box top. Bind the lashing.
- ⑧ Repeat step 7 above using clevises 12 and 12A and the center front of the fourth box top.
- ⑨ Pass a lashing through clevis 11, over the top of the fifth wooden box, through clevis 11A, and back to the center rear of the box top. Bind the lashing.
- ⑩ Repeat step 9 above using clevises 6 and 6A and the center front of the fifth box top.
- ⑪ Pass a lashing through clevis 5, over the top of the sixth wooden box, through clevis 5A, and back to the center rear of the box top. Bind the lashing.
- ⑫ Repeat step 11 above using clevises 1 and 1A and the center front of the sixth box top.

*Figure 3-6. Vertical lashings positioned and fastened (continued)*

### 3-8. Installing Attitude Control Bar

Install the attitude control bar using ten 16-foot lengths of type X nylon webbing, 20 D-rings, and 10 load binders as shown in Figure 3-7. Fit all D-rings and close all load binders according to FM 10-500\TO 13C7-1-5.

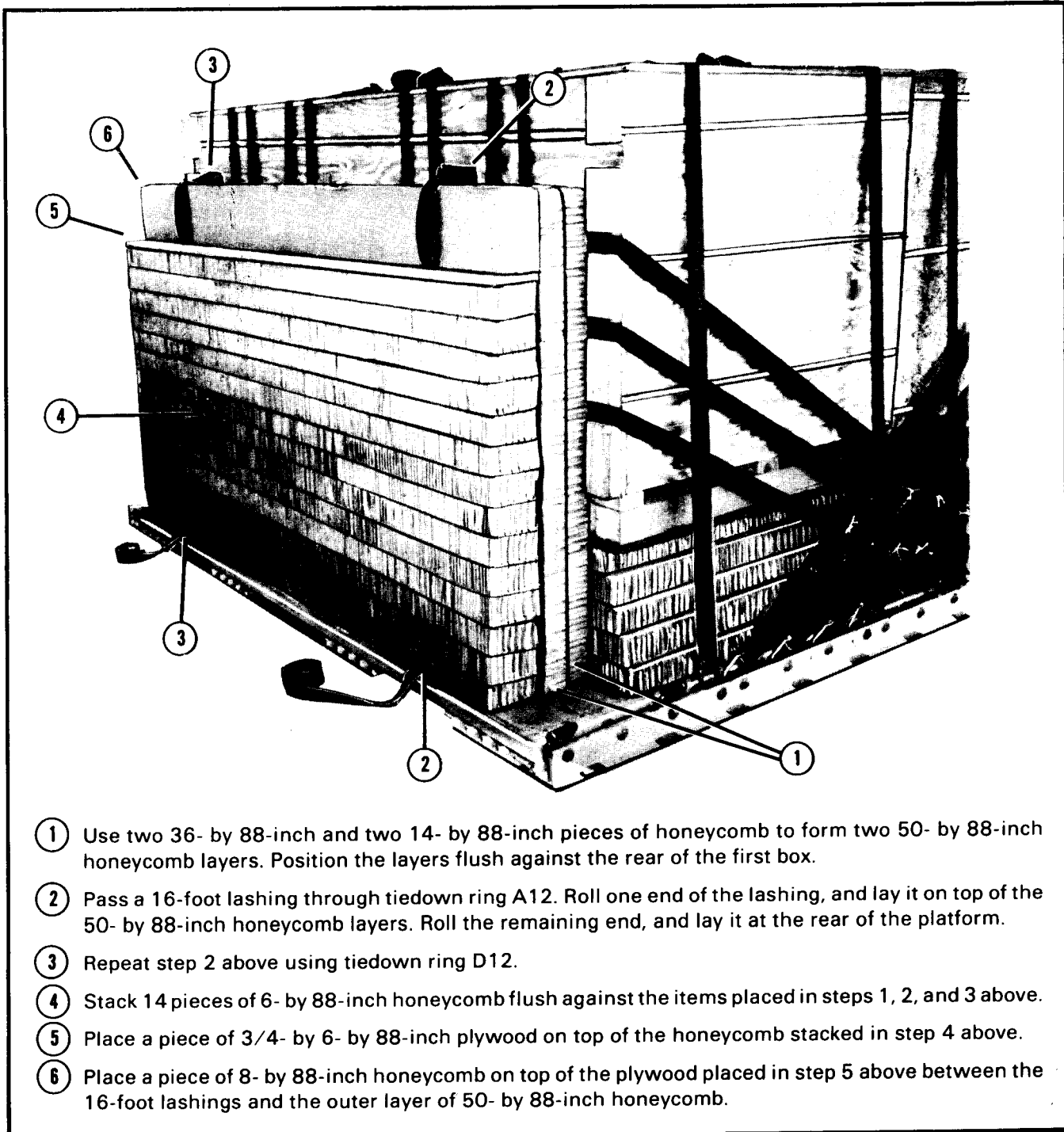

- ① Use two 36- by 88-inch and two 14- by 88-inch pieces of honeycomb to form two 50- by 88-inch honeycomb layers. Position the layers flush against the rear of the first box.
- ② Pass a 16-foot lashing through tiedown ring A12. Roll one end of the lashing, and lay it on top of the 50- by 88-inch honeycomb layers. Roll the remaining end, and lay it at the rear of the platform.
- ③ Repeat step 2 above using tiedown ring D12.
- ④ Stack 14 pieces of 6- by 88-inch honeycomb flush against the items placed in steps 1, 2, and 3 above.
- ⑤ Place a piece of 3/4- by 6- by 88-inch plywood on top of the honeycomb stacked in step 4 above.
- ⑥ Place a piece of 8- by 88-inch honeycomb on top of the plywood placed in step 5 above between the 16-foot lashings and the outer layer of 50- by 88-inch honeycomb.

Figure 3-7. Attitude control bar installed





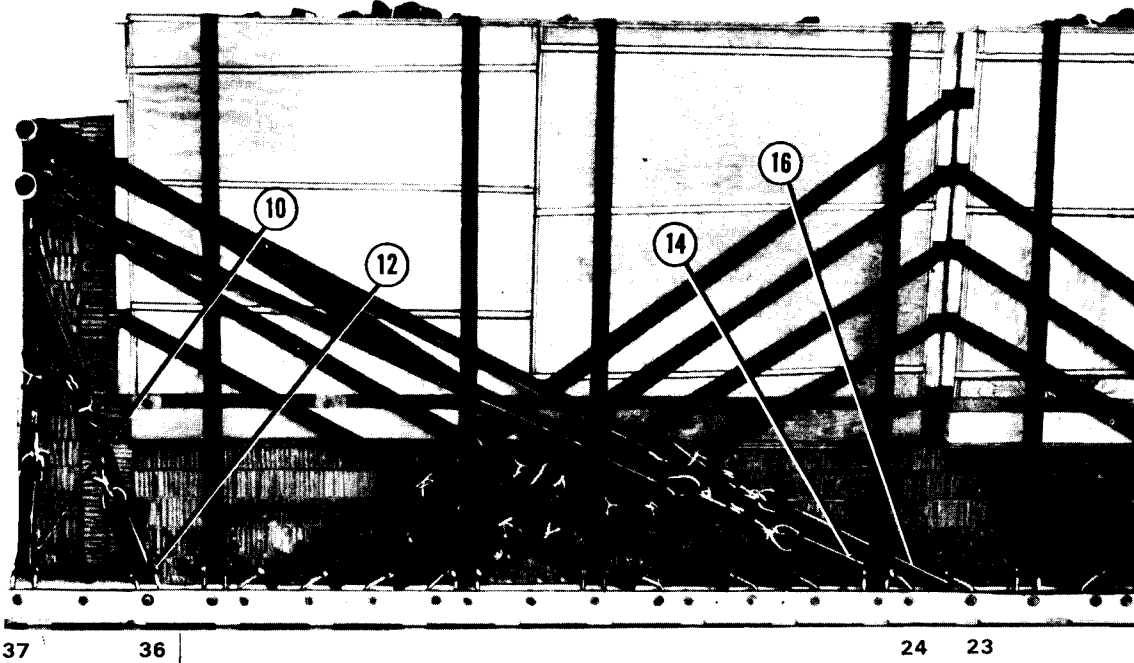

- ⑩ Pass a 16-foot lashing through clevis 37 and the closest ring on the attitude control bar. Bind the lashing.
- ⑪ Repeat step 10 above on the left side of the platform using clevis 37A (not shown).
- ⑫ Repeat step 10 above using clevis 36.
- ⑬ Repeat step 10 above on the left side of the platform using clevis 36A (not shown).
- ⑭ Pass a 16-foot lashing through clevis 24 and around the right lower bar of the attitude control bar. Bind the lashing.
- ⑮ Repeat step 14 above on the left side of the platform using clevis 24A (not shown).
- ⑯ Repeat step 14 above using clevis 23 and the right upper bar.
- ⑰ Repeat step 14 above on the left side of the platform using clevis 23A and the upper bar (not shown).

*Figure 3-7. Attitude control bar installed (continued)*

### 3-9. Installing Extraction System

Install the extraction system according to FM 10-500/TO 13C7-1-5 and as shown in Figure 3-8.

load for installation in the aircraft according to FM 10-500/TO 13C7-1-5.

### 3-10. Placing Extraction Parachutes

Place a 15-foot cargo extraction parachute with a 60-foot (1-loop), type XXVI nylon webbing extraction line and one 28-foot cargo extraction parachute (packed for LAPE) with a 60-foot (3-loop), type XXVI nylon webbing extraction line on the

#### NOTES:

1. Use a deployment line bag.
2. Lay a 12- by 12-inch piece of felt or honeycomb on the platform to pad the coupling link assembly in the aircraft.

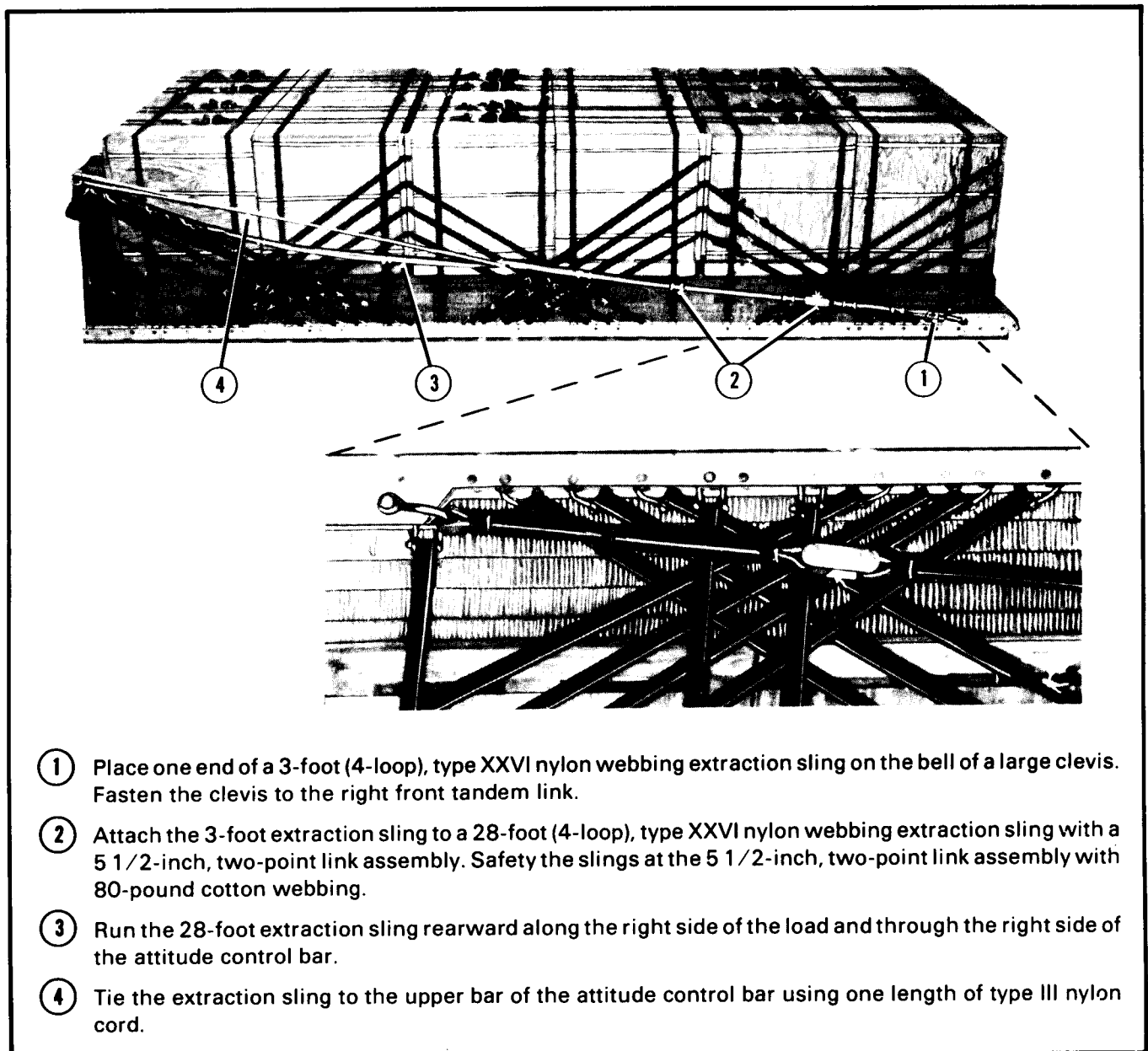
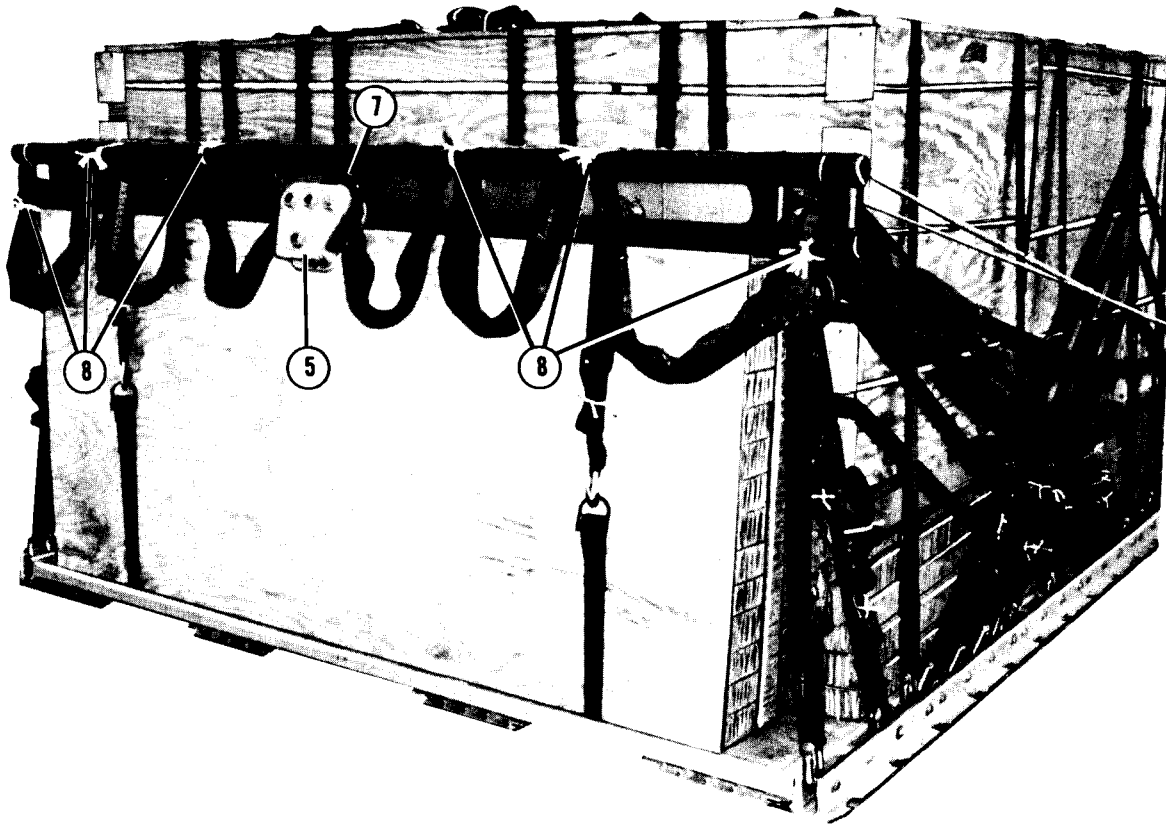

Figure 3-8. Extraction system installed



- ⑤ Attach the extraction sling to a four-point link assembly at the rear of the load.
- ⑥ Repeat steps 1 through 5 on the left side of the load (not shown).
- ⑦ Tie the four-point link assembly to the center brace of the attitude control bar with 1-inch tubular nylon webbing.
- ⑧ Fold and tie the extraction slings to the attitude control bar with six ties. Make each tie with five lengths of 80-pound cotton webbing.

*Figure 3-8. Extraction system installed (continued)*

### 3-11. Marking Rigged Load

Mark the rigged load according to FM 10-500/TO 13C7-1-5 and as shown in Figure 3-9. If the load varies from the one shown in Figure 3-9, the height, weight, CB, and parachute requirements must be recomputed.

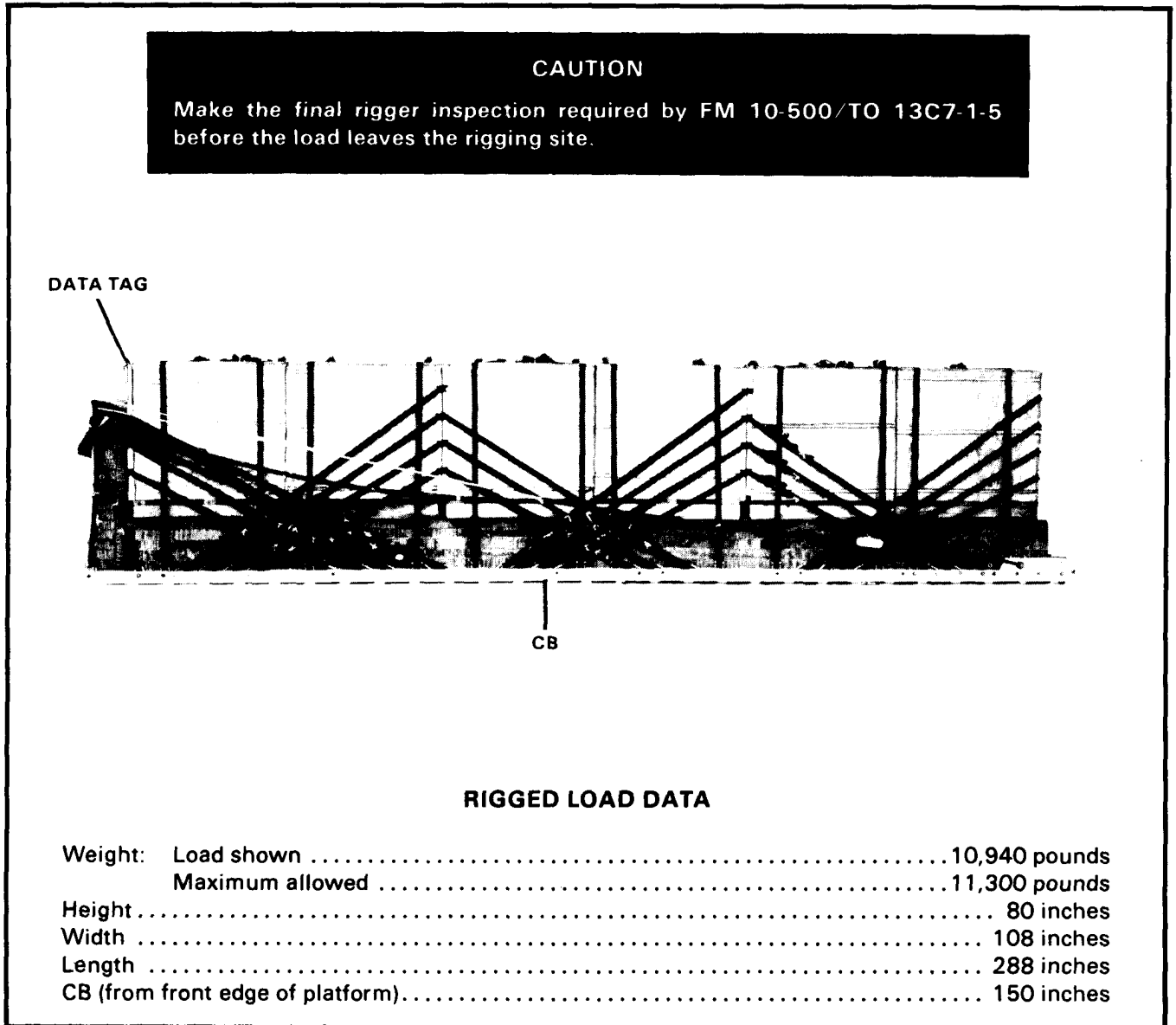

*Figure 3-9. Whole blood rigged for LAPE airdrop on a type V airdrop platform*

### 3-12. Equipment Required

Use the equipment listed in Table 3-1 to rig this load.

Table 3-1. Equipment required for rigging whole blood for LAPE airdrop on a type V platform

National Stock Number	Item	Quantity
8040-00-273-8713	Adhesive, paste, 1-gal	As required
1670-00-003-4389	Bar, attitude control	1
3990-00-937-0272	Binder, load, 10,000-lb	59
1670-01-035-6054	Bridle, extraction line bag, use w extraction line leaf	1
4030-00-090-5354	Clevis, suspension, 1-in (large)	2
4020-00-240-2146	Cord, nylon, type III, 550-lb	As required
8135-00-664-6958	Cushioning material, packaging, cellulose wadding	As required
5365-00-937-0147	D-ring, heavy-duty, 10,000-lb	118
8305-00-958-3685	Felt, 1/2-in thick	As required
1670-01-183-2678	Leaf, extraction line (line bag)	2
	Line, extraction, type XXVI nylon webbing:	
1670-01-064-4452	60-ft (1-loop)	1
1670-01-062-6313	60-ft (3-loop)	1
	Link assembly:	
1670-01-072-1378	Extraction (LAPE)	1
1670-00-006-2752	Four-point	1
	Two-point:	3
5306-00-435-8994	Bolt, 1-in diam, 4-in long	(6)
5310-00-232-5165	Nut, 1-in	(6)
1670-00-003-1954	Plate, side, 5 1/2-in	(6)
5365-00-007-3414	Spacer, large	(6)
1670-00-783-5988	Type IV	1
5510-00-220-6146	Lumber, 2- by 4-in:	
	6-in	48
	7 1/2-in	12
	42-in	12
	86-in	12
	95 1/2-in	18
5510-00-220-6274	Lumber, 4- by 4- by 43 1/2-in	30
	Nail, steel wire, common:	
5315-00-162-3151	4d	As required
5315-00-010-4657	6d	As required
5315-00-010-4659	8d	As required
5315-00-010-4661	10d	As required
1670-00-753-3928	Pad, energy-dissipating, honeycomb,	
	3- by 36- by 96-in:	36 sheets
	2- by 94-in	(120)
	4- by 68-in	(12)
	6- by 68-in	(12)
	6- by 88-in	(14)
	6- by 94-in	(12)
	8- by 80-in	(9)
	8- by 88-in	(1)

Table 3-1. Equipment required for rigging whole blood for LAPE airdrop on a type V platform (continued)

National Stock Number	Item	Quantity
	10- by 68-in	(12)
	12- by 12-in	(1)
	12- by 68-in	(12)
	14- by 88-in	(2)
	36- by 88-in	(2)
	36- by 94-in	(12)
	91 1/2- by 8-in	(4)
	Parachute, cargo extraction:	
1670-00-052-1548	15-ft <i>or</i>	1
1670-01-063-3715	15-ft	1
1670-00-262-1797	28-ft (packed for LAPE) <i>or</i>	1
1670-00-040-8135	28-ft, heavy-duty (packed for LAPE)	1
	Platform, airdrop, type V, 24-ft:	1
1670-01-162-2385	Bumper, nose	(1)
1670-01-162-2372	Clevis, load tiedown	(74)
1670-01-162-2381	Tandem link	(2)
5530-00-128-4981	Plywood, 3/4-in:	
	6- by 88-in	1
	39 1/2- by 42-in	12
	39 1/2- by 95 1/2-in	12
	42- by 88-in	1
	42- by 94-in	6
	43 1/2- by 95 1/2-in	12
	Sling, cargo, airdrop:	
	For extraction:	
1670-01-062-6306	3-ft (4-loop), type XXVI nylon webbing	2
1670-01-062-6309	28-ft (4-loop), type XXVI nylon webbing	2
8135-00-283-0667	Strapping, steel, 5/8-in	
7510-00-266-5016	Tape, adhesive, 2-in	As required
	Webbing:	As required
8305-00-268-2411	Cotton, 80-lb	As required
8305-00-082-5752	Nylon, tubular, 1/2-in, 1,000-lb, natural	As required
8305-00-268-2455	Nylon, tubular, 1-in, 4,000-lb, olive drab	As required
8305-00-263-3591	Nylon, type VIII, 3,600-lb	As required
8305-00-261-8584	Nylon, type X, treated, 8,700-lb, olive drab	As required

## CHAPTER 4

## RIGGING WHOLE BLOOD ON A 32-FOOT, TYPE V AIRDROP PLATFORM FOR LAPE AIRDROP

### 4-1. Description of Load

Whole blood is rigged on a 32-foot, type V airdrop platform with two 28-foot extraction parachutes (packed for LAPE) and one 15-foot extraction parachute (drogue) for C-130 aircraft.

### 4-2. Preparing Platform

Prepare a 32-foot, type V airdrop platform as described below.

#### a. Assembling and Inspecting Platform.

Inspect, or assemble and inspect, the platform as outlined in TM 10-1670-268-20&P/TO 13C7-52-22.

**b. Installing Tandem Links.** Install a tandem link on the front of each rail as shown in Figure 4-1.

**c. Attaching and Numbering Clevises.** Bolt 96 tiedown clevises to the side rail bushings and tandem links according to TM 10-1670-268-20&P/TO 13C7-52-22 and as shown in Figure 4-1. Number the clevises as shown in Figure 4-1.

**NOTE:** The nose bumper must be installed.

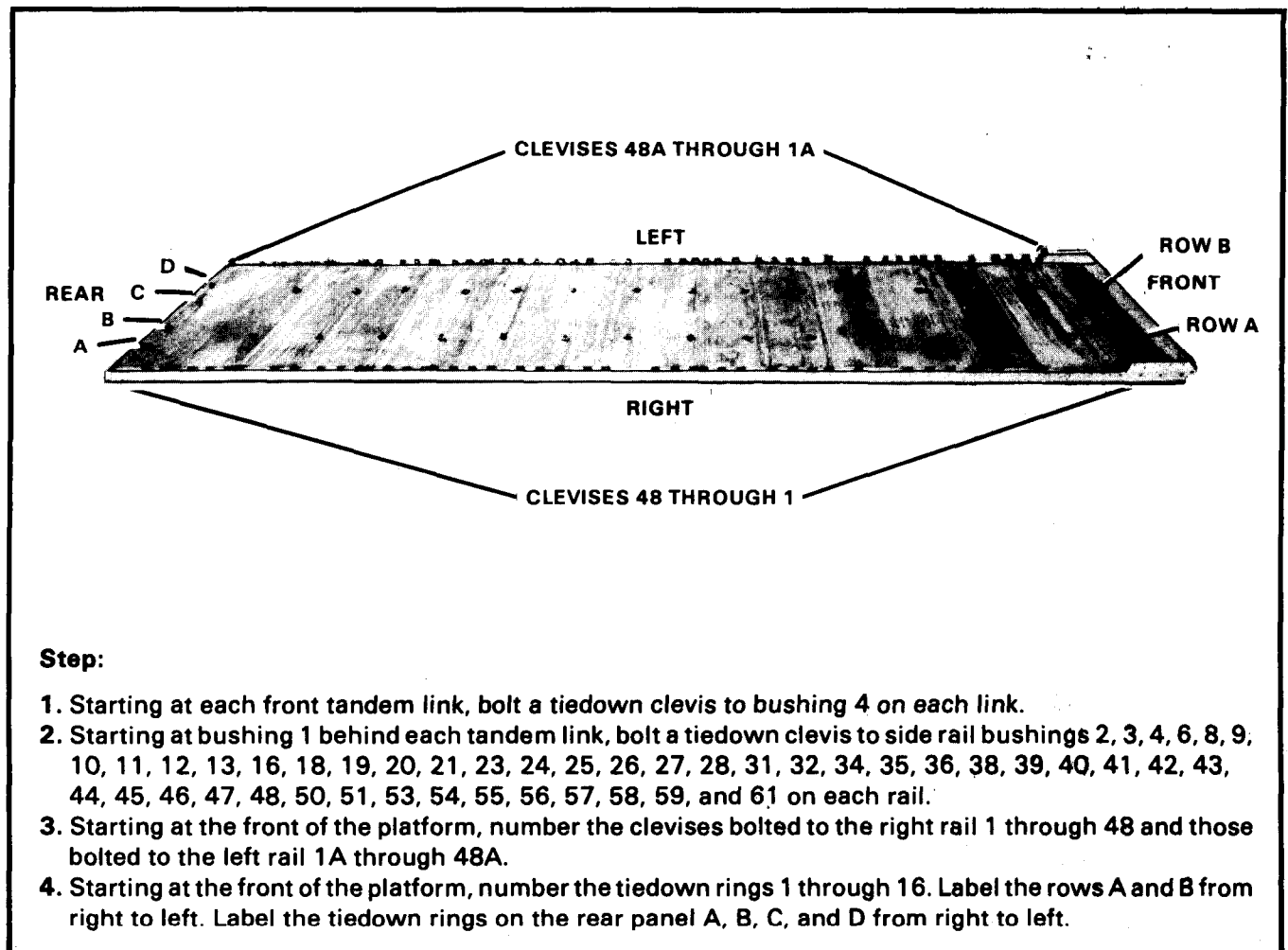

Figure 4-1. Platform prepared



**4-3. Preparing and Placing Honeycomb Layers**

Prepare and place the honeycomb layers as shown in Figures 4-2 and 4-3.

**4-4. Preparing Wooden Boxes**

Prepare eight wooden boxes as described in paragraph 2-4.

**NOTE: Glue all honeycomb layers together.  
Do not glue the layers to the platform.**

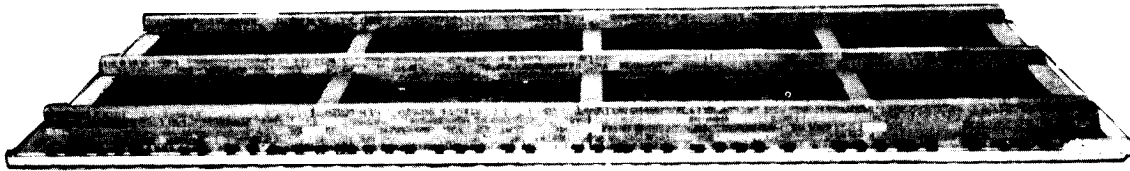

Layer Number	Pieces	Width (Inches)	Length (Inches)	Material	Instructions			
1	12	12	90 1/2	Honeycomb	Lay four pieces of honeycomb end to end forming a 362-inch row. Prepare two more 362-inch rows. Lay each row 29 3/4 inches apart and 13 inches from the rear edge of the platform. Outside rows are 2 3/4 inches from the side rails.			
2	12	10	90 1/2	Honeycomb	Center four pieces of honeycomb end to end on top of each row in layer 1.			
3	5	91 1/2	8	Honeycomb	Use honeycomb as bridges. Lay one piece across layer 2 flush with front edge of the honeycomb. Lay the second piece across layer 2, 89 inches from front edge of the honeycomb. Lay the third piece across layer 2, 178 inches from front edge of the honeycomb. Lay the fourth piece across layer 2, 88 inches from rear edge of the honeycomb. Lay the fifth piece flush with rear edge of the honeycomb.			
	6				8	81	Honeycomb	Use honeycomb as fillers between the three front bridges.
	6				8	80	Honeycomb	Use honeycomb as fillers between the last bridges to complete layer 3.
4	12	6	90 1/2	Honeycomb	Center four pieces of honeycomb end to end on top of each 362-inch row in layer 3.			
5	12	4	90 1/2	Honeycomb	Center four pieces of honeycomb end to end on top of each row in layer 4.			

*Figure 4-2. Honeycomb layers prepared and placed on platform*

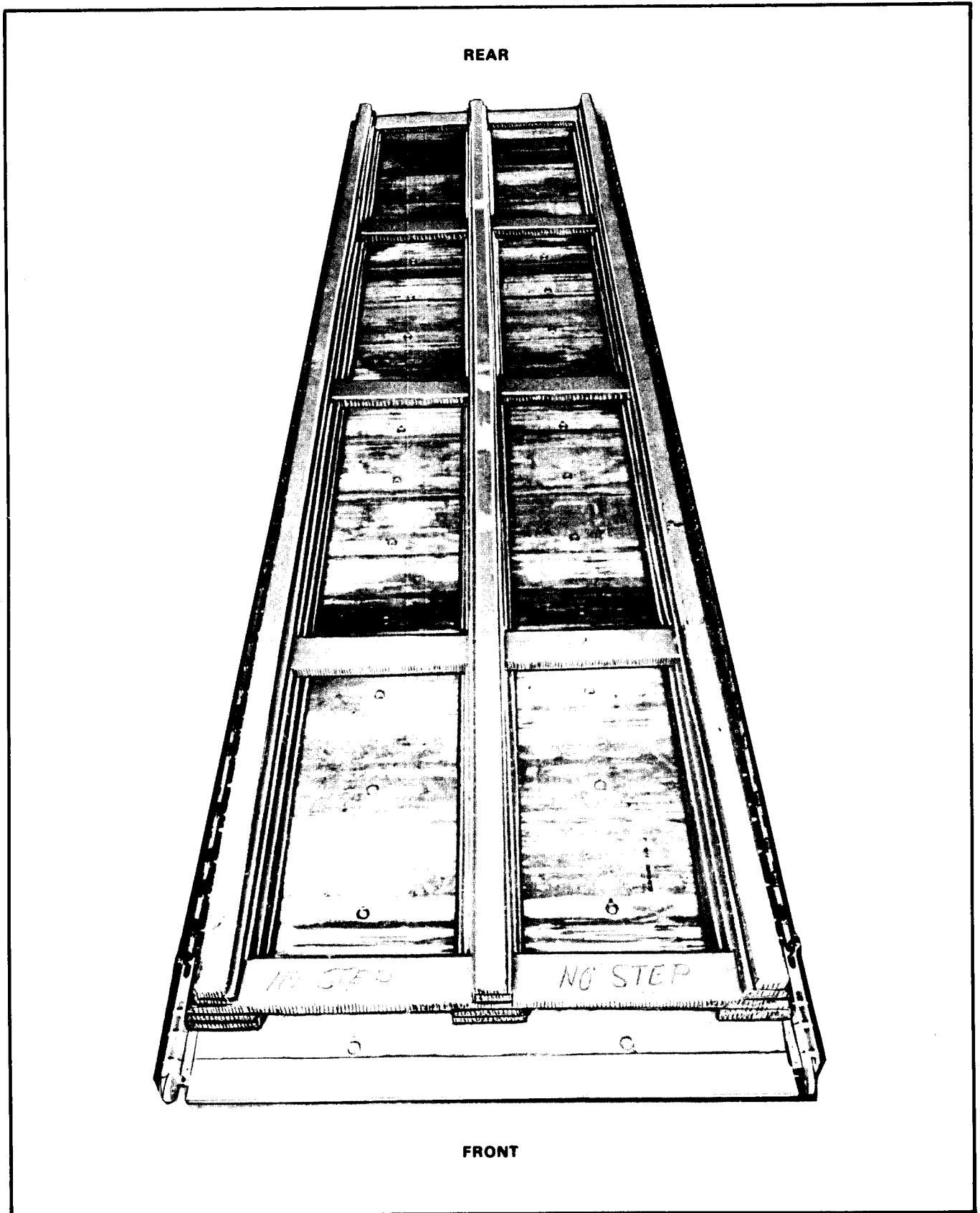

Figure 4-3. Front view of honeycomb layers placed on platform

### 4-5. Positioning and Lashing Wooden Boxes

Position and lash eight wooden boxes on the honeycomb as shown in Figure 4-4. Lash the boxes using thirty-two 48-foot lengths of type X nylon webbing, sixteen 16-foot lengths of type X nylon webbing, 96 D-rings, and 48 load binders. Position four 48-foot lashings to be used later for securing the wooden box tops. Position the remaining 28 lashings, and fasten them immediately after they have been positioned on each pair of boxes. Position the sixteen 16-foot lashings to be used

later for securing the wooden box tops in pairs. Fit all D-rings and close all load binders according to FM 10-500/TO 13C7-1-5.

**CAUTION**  
Positioning of the load binders is critical. Place the load binders exactly where shown.

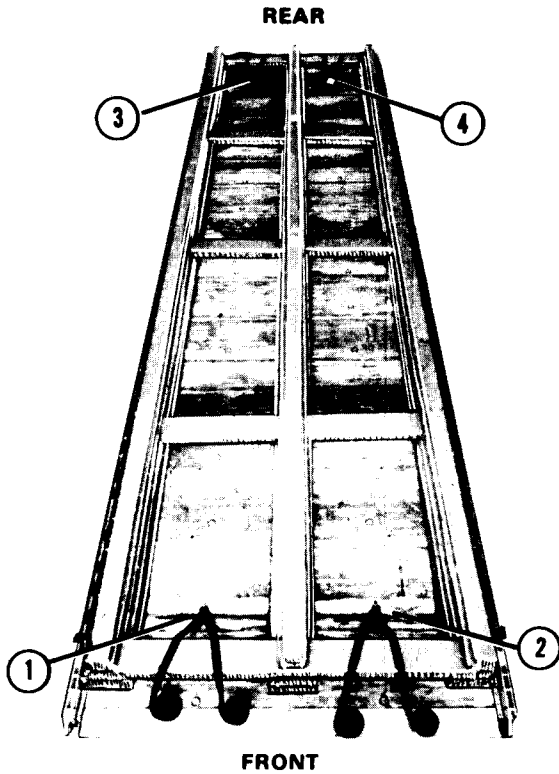

- ① Pass one 48-foot lashing through tiedown ring A2. Bring the ends of the lashing over the top of the front bridge to the front of the platform, and roll them. (This pre-positioned lashing will be used to lash all eight wooden box tops together.)
- ② Repeat step 1 above using tiedown ring B2. (This pre-positioned lashing will be used to lash all eight wooden box tops together.)
- ③ Pass one 48-foot lashing through tiedown ring A15. Bring the ends of the lashing over the top of the rear bridge to the rear of the platform, and roll them. (This pre-positioned lashing will be used to lash all eight wooden box tops together.)
- ④ Repeat step 3 above using tiedown ring B15. (This pre-positioned lashing will be used to lash all eight wooden box tops together.)

Figure 4-4. Wooden boxes positioned and lashed

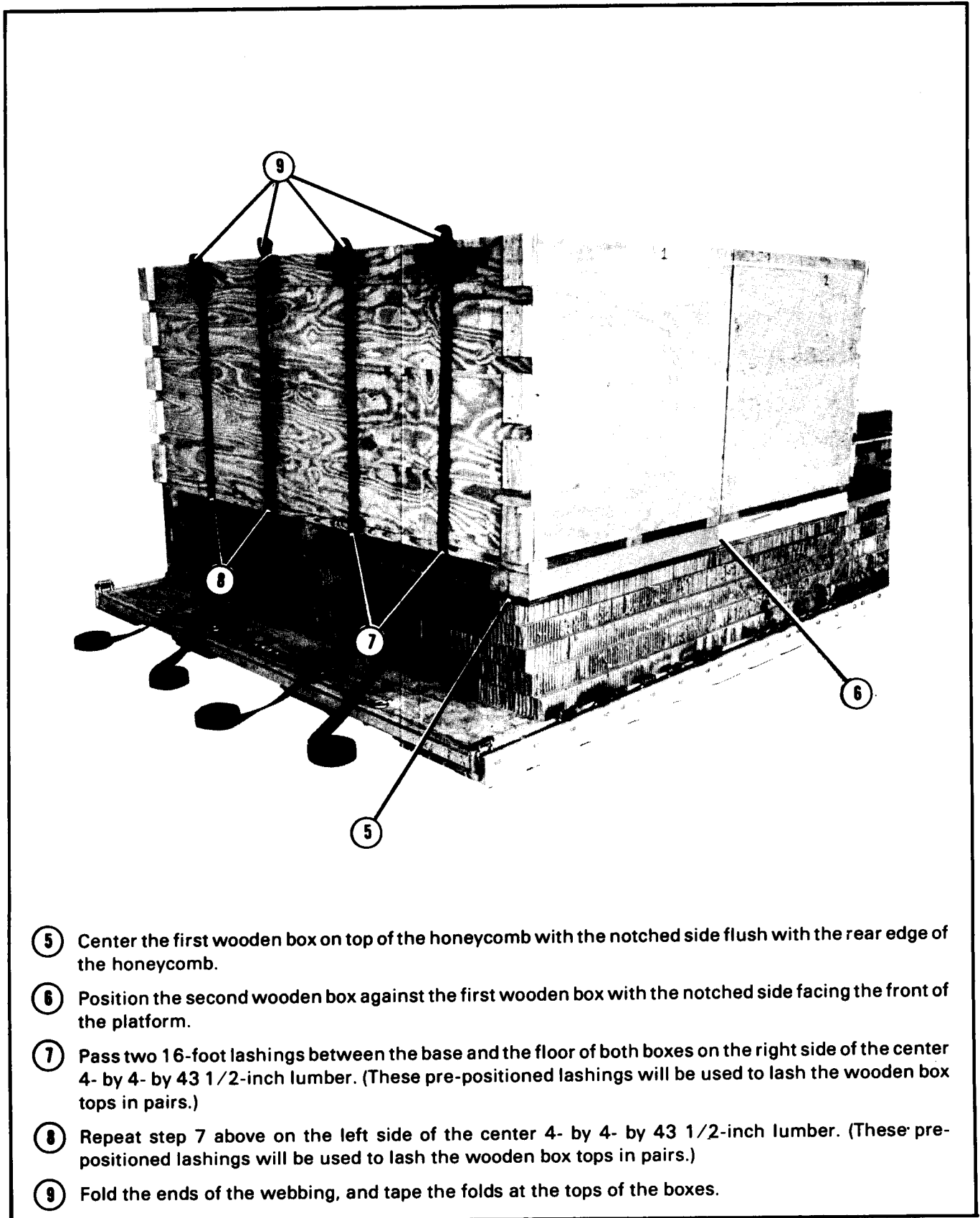

- ⑤ Center the first wooden box on top of the honeycomb with the notched side flush with the rear edge of the honeycomb.
- ⑥ Position the second wooden box against the first wooden box with the notched side facing the front of the platform.
- ⑦ Pass two 16-foot lashings between the base and the floor of both boxes on the right side of the center 4- by 4- by 43 1/2-inch lumber. (These pre-positioned lashings will be used to lash the wooden box tops in pairs.)
- ⑧ Repeat step 7 above on the left side of the center 4- by 4- by 43 1/2-inch lumber. (These pre-positioned lashings will be used to lash the wooden box tops in pairs.)
- ⑨ Fold the ends of the webbing, and tape the folds at the tops of the boxes.

*Figure 4-4. Wooden boxes positioned and lashed (continued)*

**NOTE: Lash the boxes in pairs.**

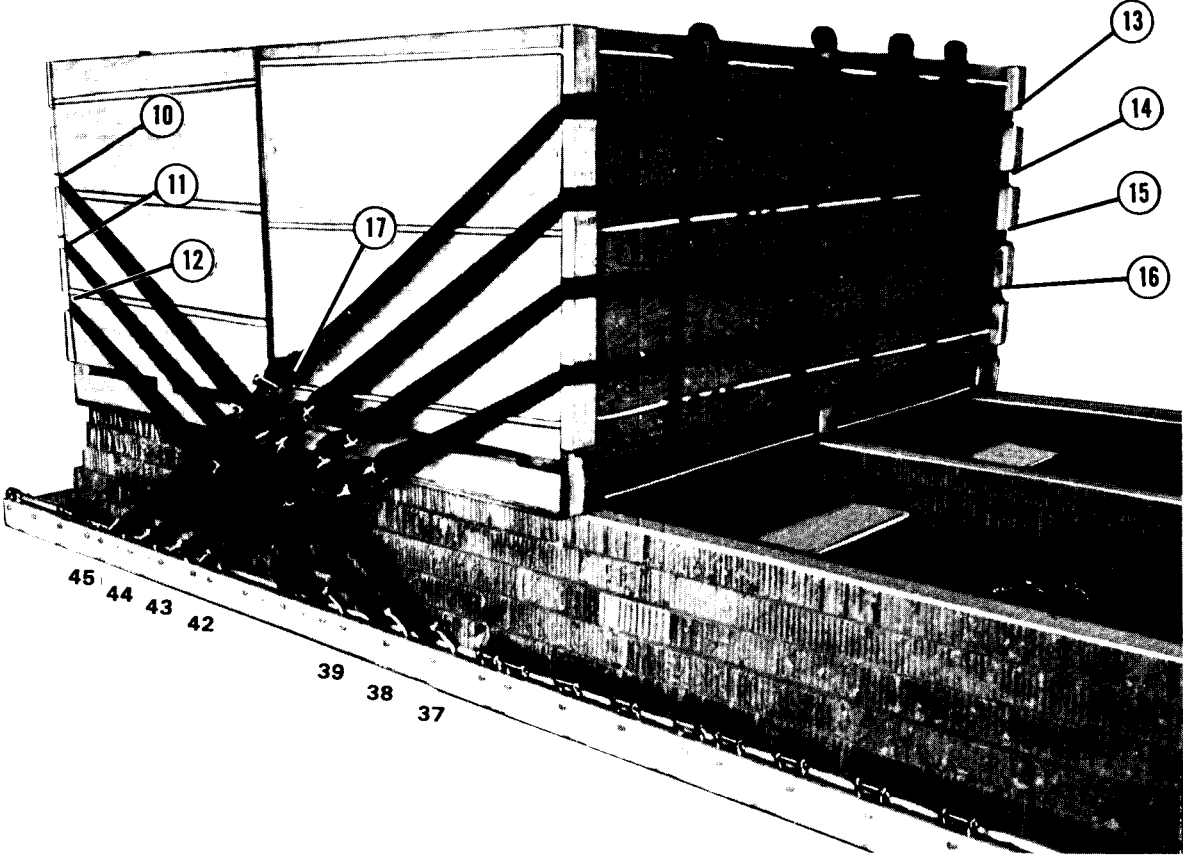

- ⑩ Pass a lashing through clevis 37, through the second notch from the top on both sides of the first box, through clevis 37A, and back to the right side of the platform.
- ⑪ Repeat step 10 above using clevises 38 and 38A and the third notch from the top.
- ⑫ Repeat step 10 above using clevises 39 and 39A and the bottom notch.
- ⑬ Pass a lashing through clevis 45, through the top notch on both sides of the second box, through clevis 45A, and back to the right side of the platform.
- ⑭ Repeat step 13 above using clevises 44 and 44A and the second notch from the top.
- ⑮ Repeat step 13 above using clevises 43 and 43A and the third notch from the top.
- ⑯ Repeat step 13 above using clevises 42 and 42A and the bottom notch.
- ⑰ Bind lashings placed in steps 10, 11, and 12 first; then bind lashings placed in steps 13 through 16.

*Figure 4-4. Wooden boxes positioned and lashed (continued)*

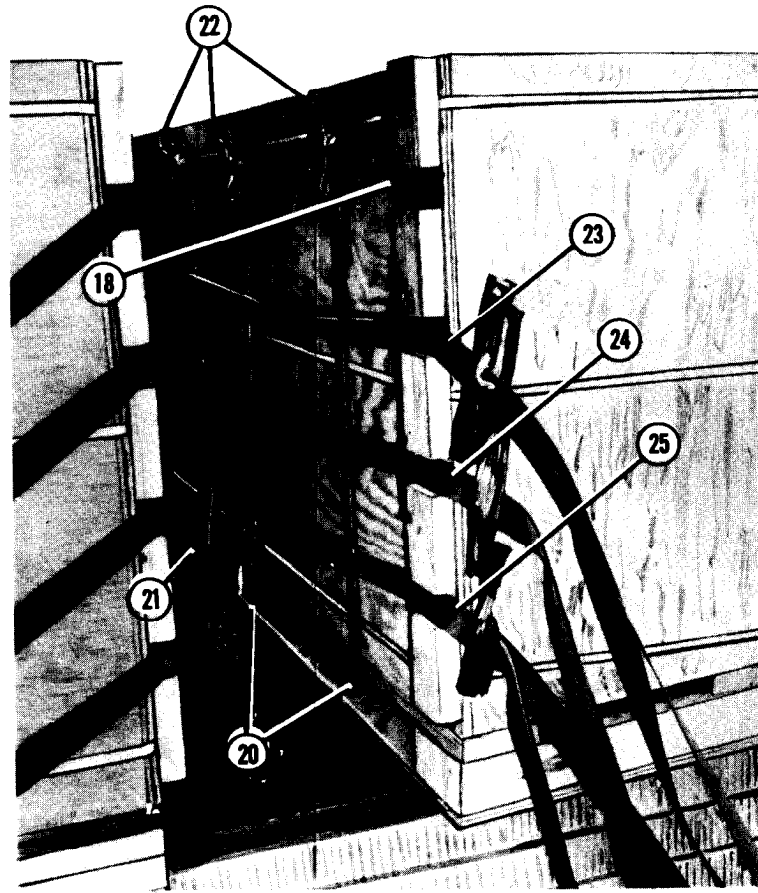

- ⑱ Position the third wooden box on top of the honeycomb with the notched side 24 inches from the front of the second box.
- ⑲ Position the fourth wooden box against the third box with the notched side facing the front of the platform (not shown).
- ⑳ Pass two 16-foot lashings between the base and the floor of both boxes on the right side of the center 4- by 4- by 43 1/2-inch lumber. (These pre-positioned lashings will be used to lash the wooden box tops in pairs.)
- ㉑ Repeat step 20 above on the left side of the center 4- by 4- by 43 1/2-inch lumber. (These pre-positioned lashings will be used to lash the wooden box tops in pairs.)
- ㉒ Fold the ends of the webbing, and tape the folds at the tops of the boxes.
- ㉓ Pass a lashing through clevis 24, through the second notch from the top on both sides of the third box, through clevis 24A, and back to the right side of the platform. Tape the lashing to the side of the box.
- ㉔ Repeat step 23 above using clevises 25 and 25A and the third notch from the top.
- ㉕ Repeat step 23 above using clevises 26 and 26A and the bottom notch.

*Figure 4-4. Wooden boxes positioned and lashed (continued)*

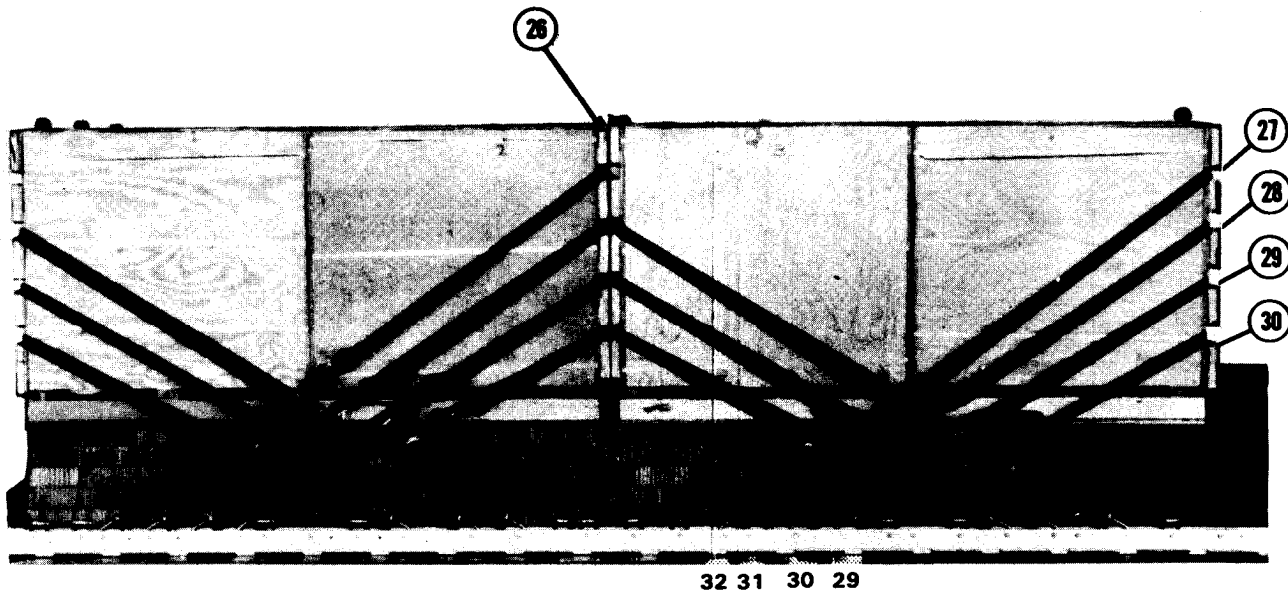

- ②6 Push the third and fourth wooden boxes flush against the second box.
- ②7 Pass a lashing through clevis 32, through the top notch on both sides of the fourth box, through clevis 32A, and back to the right side of the platform.
- ②8 Repeat step 27 above using clevises 31 and 31A and the second notch from the top.
- ②9 Repeat step 27 above using clevises 30 and 30A and the third notch from the top.
- ③0 Repeat step 27 above using clevises 29 and 29A and the bottom notch.
- ③1 Remove the tape from the lashings placed in steps 23, 24, and 25. Bind lashings placed in steps 23, 24, and 25 first; then bind the lashings placed in steps 27 through 30 (not shown).

Figure 4-4. Wooden boxes positioned and lashed (continued)

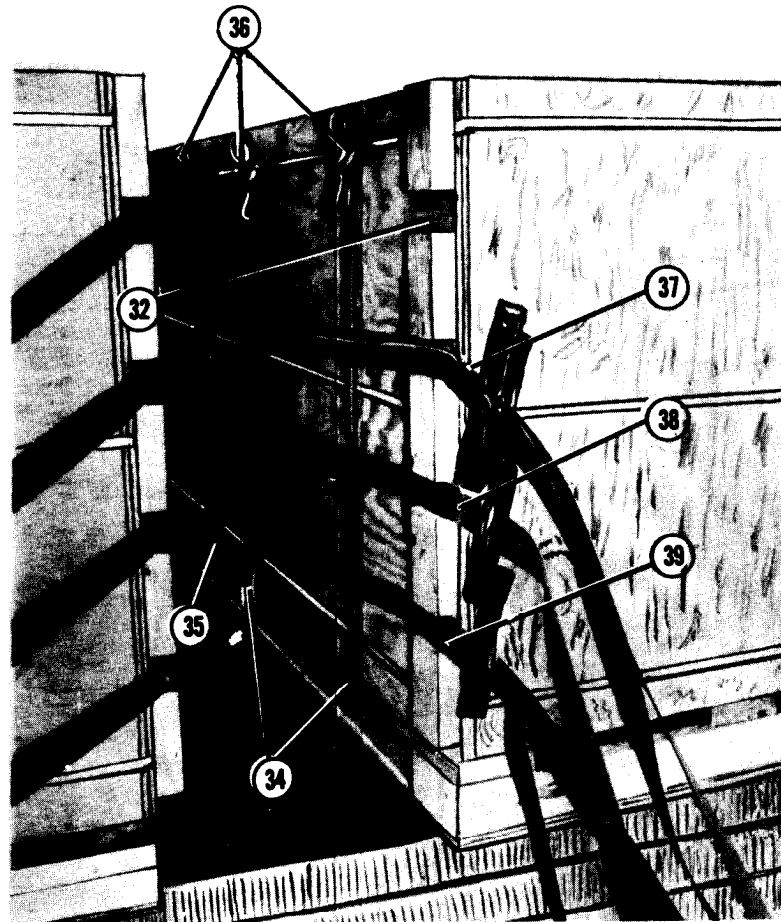

- ③② Position the fifth wooden box on top of the honeycomb with the notched side 24 inches from the front of the fourth box.
- ③③ Position the sixth wooden box against the fifth box with the notched side facing the front of the platform (not shown).
- ③④ Pass two 16-foot lashings between the base and the floor of both boxes on the right side of the center 4- by 4- by 43 1/2-inch lumber. (These pre-positioned lashings will be used to lash the wooden box tops in pairs.)
- ③⑤ Repeat step 34 above on the left side of the center 4- by 4- by 43 1/2-inch lumber. (These pre-positioned lashings will be used to lash the wooden box tops in pairs.)
- ③⑥ Fold the ends of the webbing, and tape the folds at the tops of the boxes.
- ③⑦ Pass a lashing through clevis 13, through the second notch from the top on both sides of the fifth box, through clevis 13A, and back to the right side of the platform. Tape the lashing to the side of the box.
- ③⑧ Repeat step 37 above using clevises 14 and 14A and the third notch from the top.
- ③⑨ Repeat step 37 above using clevises 15 and 15A and the bottom notch.

*Figure 4-4. Wooden boxes positioned and lashed (continued)*



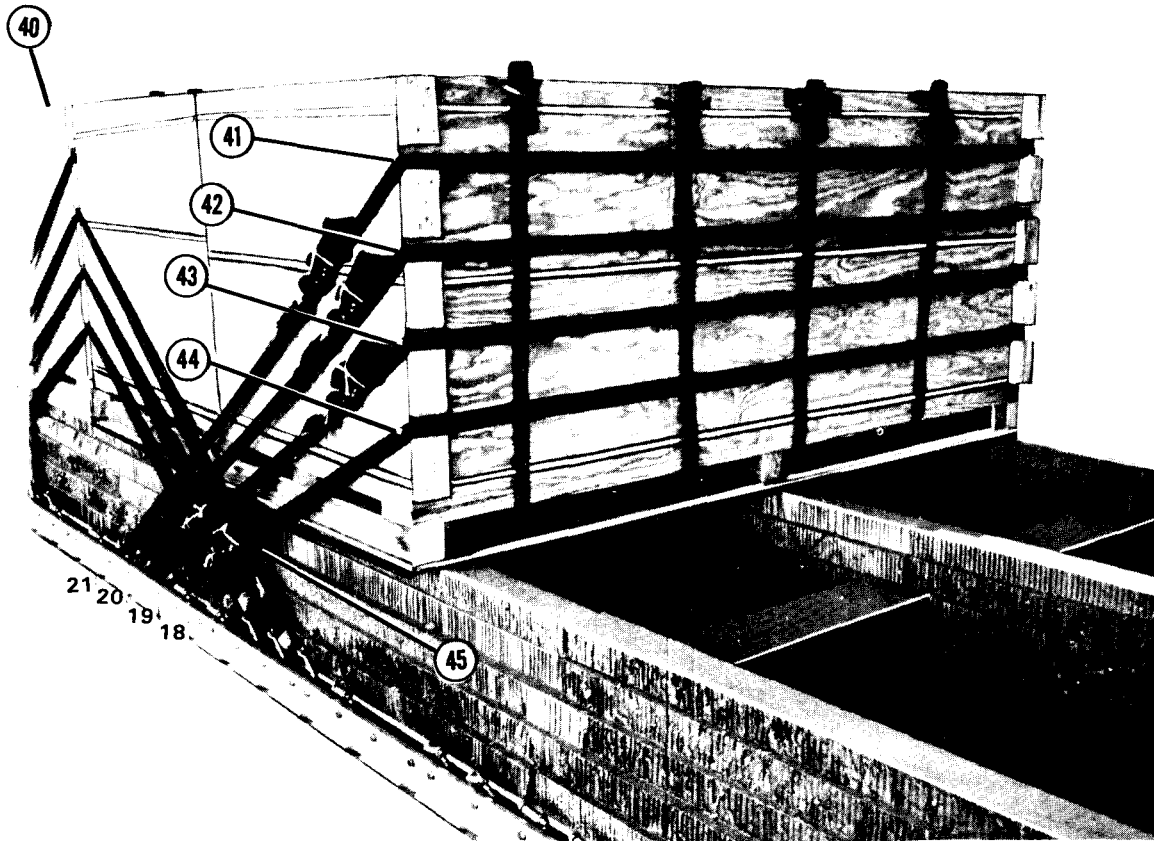

- ④④ Push the fifth and sixth wooden boxes flush against the fourth box.
- ④① Pass a lashing through clevis 21, through the top notch on both sides of the sixth box, through clevis 21A, and back to the right side of the box.
- ④② Repeat step 41 above using clevises 20 and 20A and the second notch from the top.
- ④③ Repeat step 41 above using clevises 19 and 19A and the third notch from the top.
- ④④ Repeat step 41 above using clevises 18 and 18A and the bottom notch.
- ④⑤ Remove the tape from the lashings placed in steps 37, 38, and 39. Bind lashings placed in steps 37, 38, and 39 first; then bind lashings placed in steps 41 through 44.

*Figure 4-4. Wooden boxes positioned and lashed (continued)*

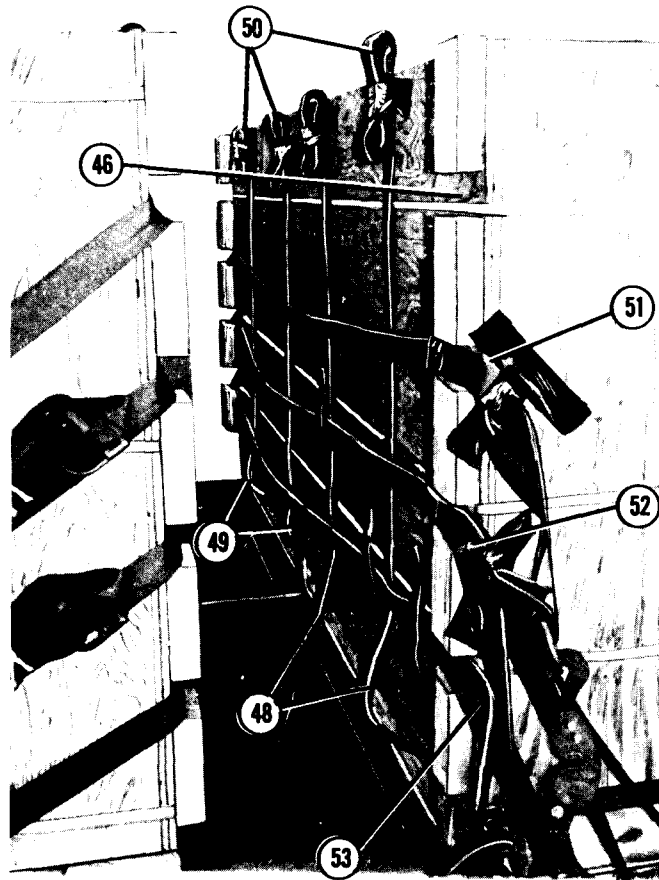

- ④⑥ Position the seventh wooden box on top of the honeycomb with the notched side 24 inches from the front of the sixth box.
- ④⑦ Position the eighth wooden box against the seventh box with the notched side facing the front of the platform (not shown).
- ④⑧ Pass two 16-foot lashings between the base and the floor of both boxes on the right side of the center 4- by 4- by 43 1/2-inch lumber. (These pre-positioned lashings will be used to lash the wooden box tops in pairs.)
- ④⑨ Repeat step 48 above on the left side of the center 4- by 4- by 43 1/2-inch lumber. (These pre-positioned lashings will be used to lash the wooden box tops in pairs.)
- ⑤⑩ Fold the ends of the webbing, and tape the folds at the tops of the boxes.
- NOTE: Tape on the rear of the box is used as a rigging aid. It may or may not be removed.**
- ⑤① Pass a lashing through clevis 2, through the second notch from the top on both sides of the seventh box, through clevis 2A, and back to the right side of the platform. Tape the lashing to the side of the box.
- ⑤② Repeat step 51 above using clevises 3 and 3A and the third notch from the top.
- ⑤③ Repeat step 51 above using clevises 4 and 4A and the bottom notch.

*Figure 4-4. Wooden boxes positioned and lashed (continued)*

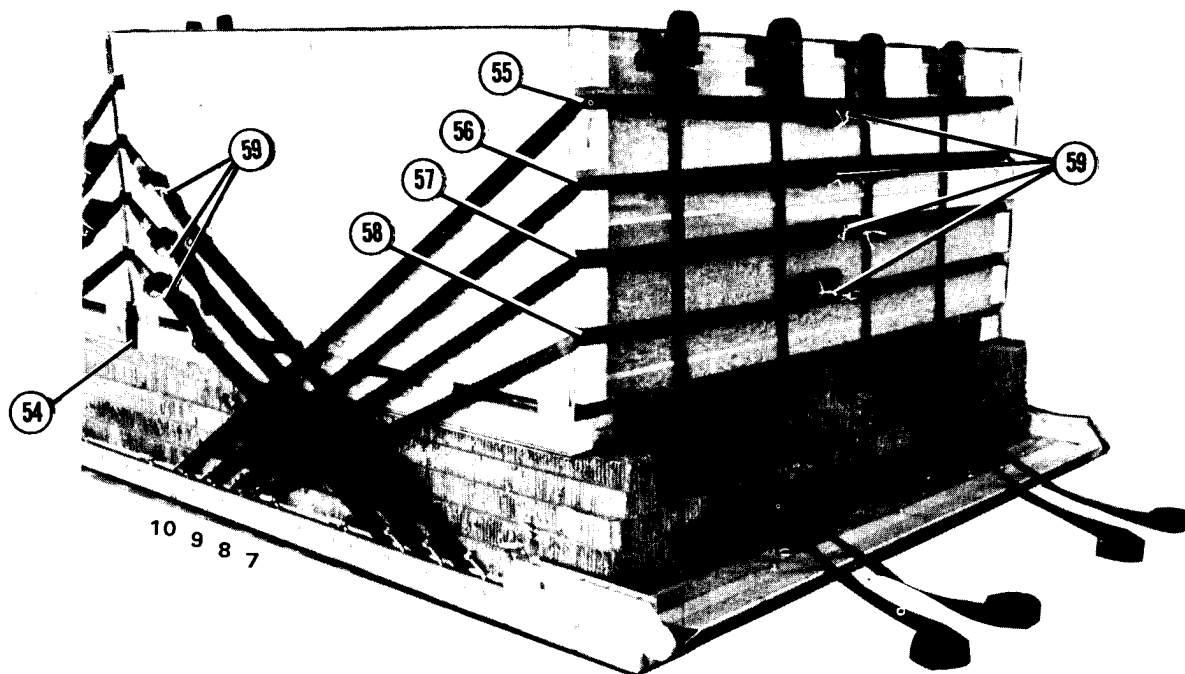

- ⑤④ Push the seventh and eighth wooden boxes flush against the sixth box.
- ⑤⑤ Pass a lashing through clevis 10, through the top notch on both sides of the eighth box, through clevis 10A, and back to the center front of the box.
- ⑤⑥ Repeat step 55 above using clevises 9 and 9A and the second notch from the top.
- ⑤⑦ Repeat step 55 above using clevises 8 and 8A and the third notch from the top.
- ⑤⑧ Repeat step 55 above using clevises 7 and 7A and the bottom notch.
- ⑤⑨ Remove the tape from the lashings placed in steps 51, 52, and 53. Bind lashings placed in steps 51, 52, and 53 first; then bind lashings placed in steps 55 through 58.

*Figure 4-4. Wooden boxes positioned and lashed (continued)*

#### 4-6. Packing Blood in Cardboard Containers

Pack whole blood in cardboard containers as described in paragraph 2-6. One hundred and sixty containers are required for this load.

#### 4-7. Packing Blood Containers in Wooden Boxes

Once the blood containers are delivered to the rigging site, pack them in eight wooden boxes as described in paragraph 2-7a and as shown in Figure 2-7.

**a. Positioning and Lashing Wooden Box Tops.** Position and lash the wooden box tops prepared in Figure 2-4 and as shown in Figure 4-5. Lash the wooden box tops in pairs using the 16 pre-positioned lashings from Figure 4-4, steps 7, 8, 20, 21, 34, 35, 48, and 49. Lash all eight wooden box tops together using the four pre-positioned lashings from Figure 4-4, steps 1 through 4. Fit all D-rings and close all load binders according to FM 10-500/TO 13C7-1-5.

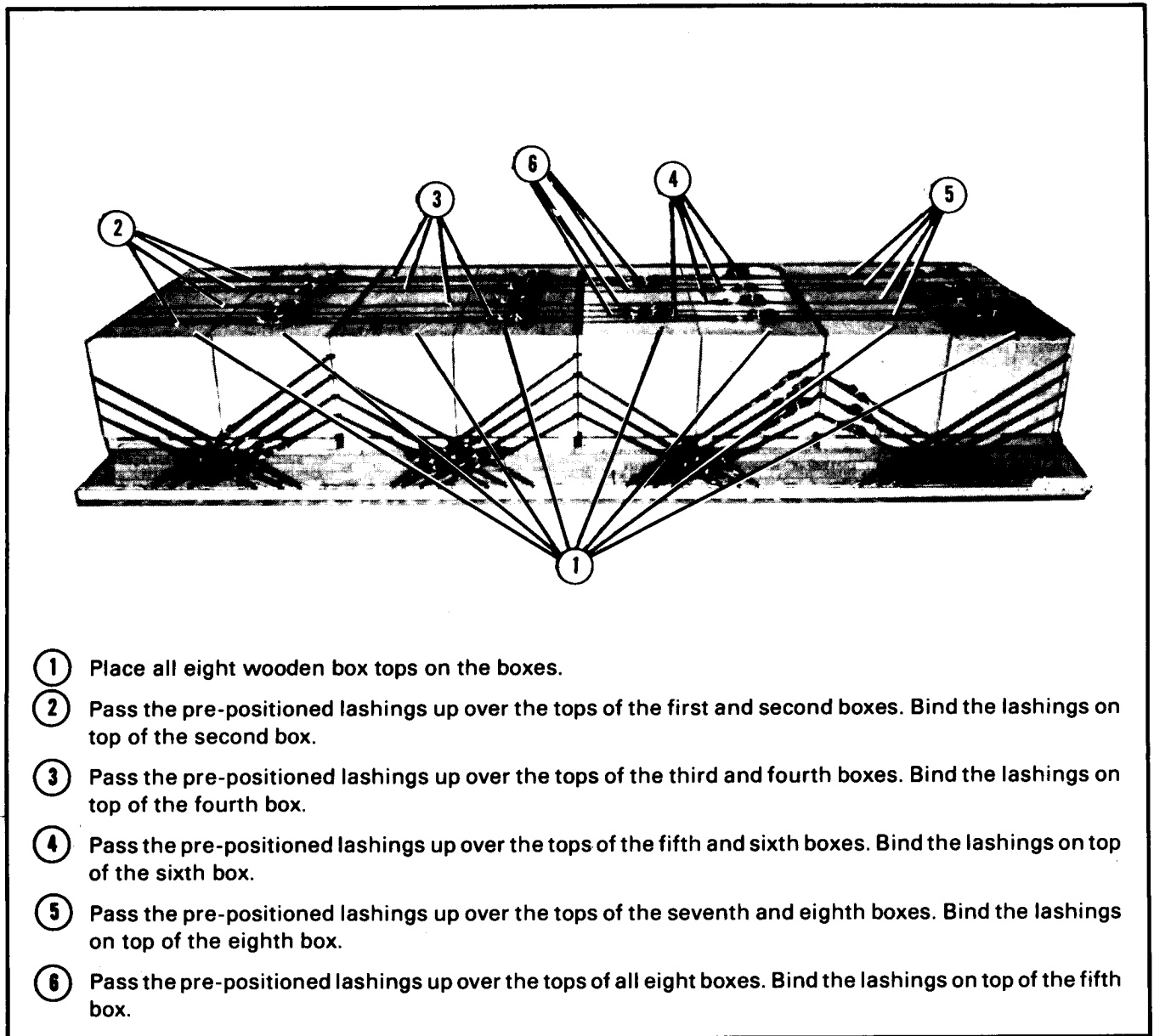

Figure 4-5. Wooden box tops positioned and lashed

**b. Positioning and Fastening Vertical Lashings.** Position and fasten the vertical lashings as shown in Figure 4-6. Use sixteen 32-foot lengths of type X nylon webbing, 32 D-rings, and 16 load binders. Fit all D-rings and close all load binders according to FM 10-500/TO 13C7-1-5.

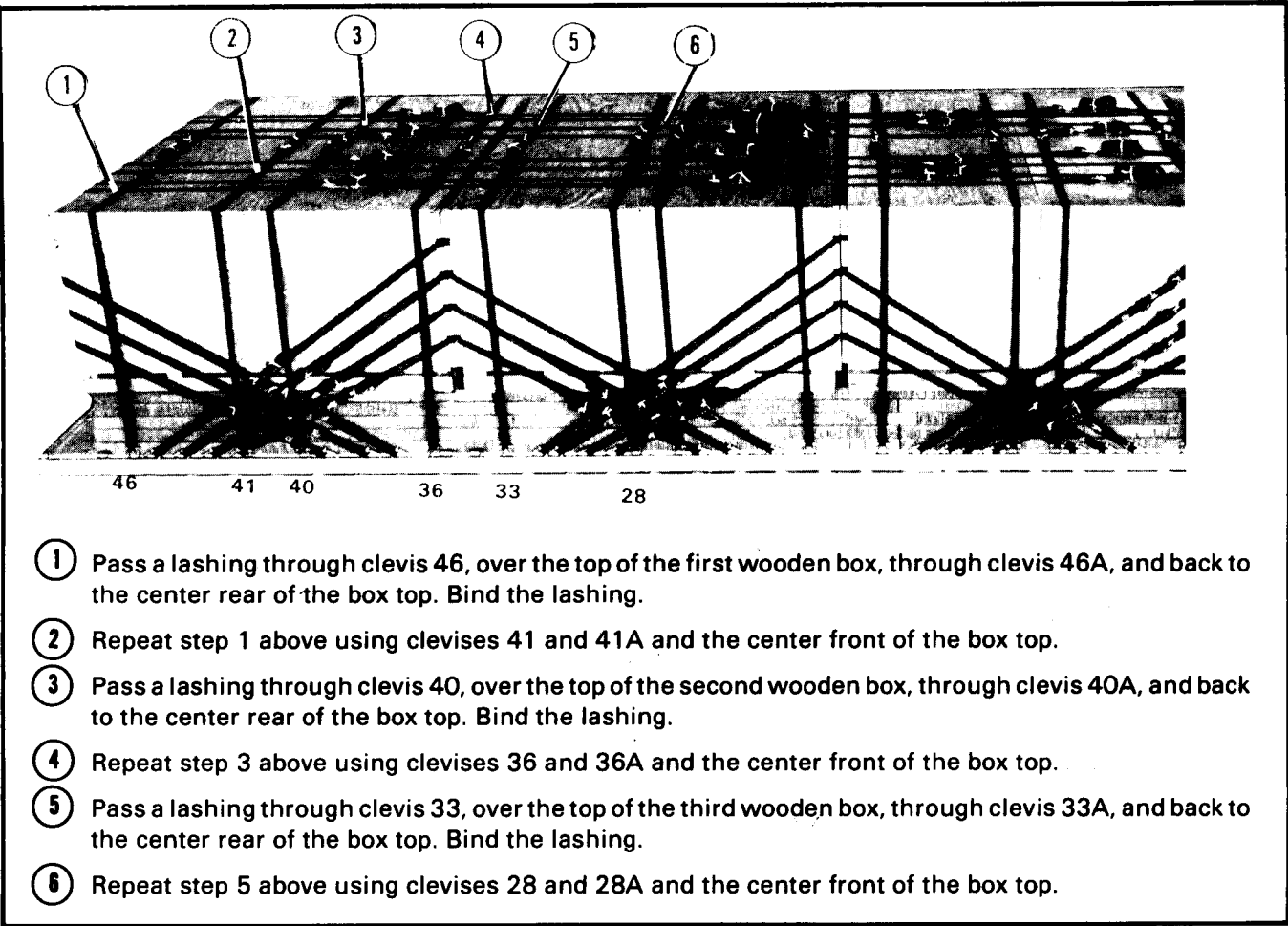
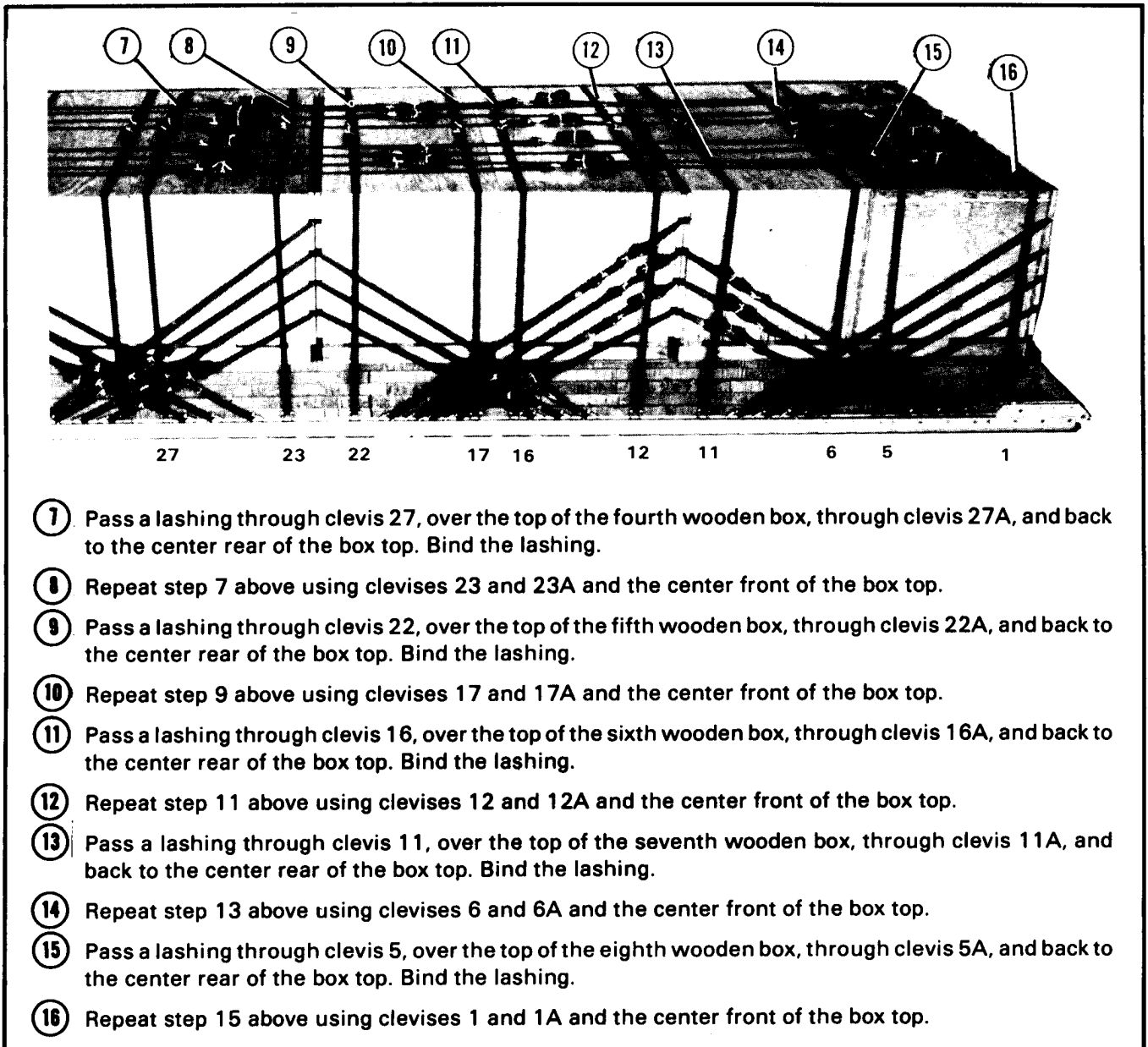

Figure 4-6. Vertical lashings positioned and fastened



*Figure 4-6. Vertical lashings positioned and fastened (continued)*

#### 4-8. Installing Attitude Control Bar

Install the attitude control bar using ten 16-foot lengths of type X nylon webbing, 20 D-rings, and 10 load binders as shown in Figure 4-7. Fit all D-rings and close all load binders according to FM 10-500/TO 13C7-1-5.

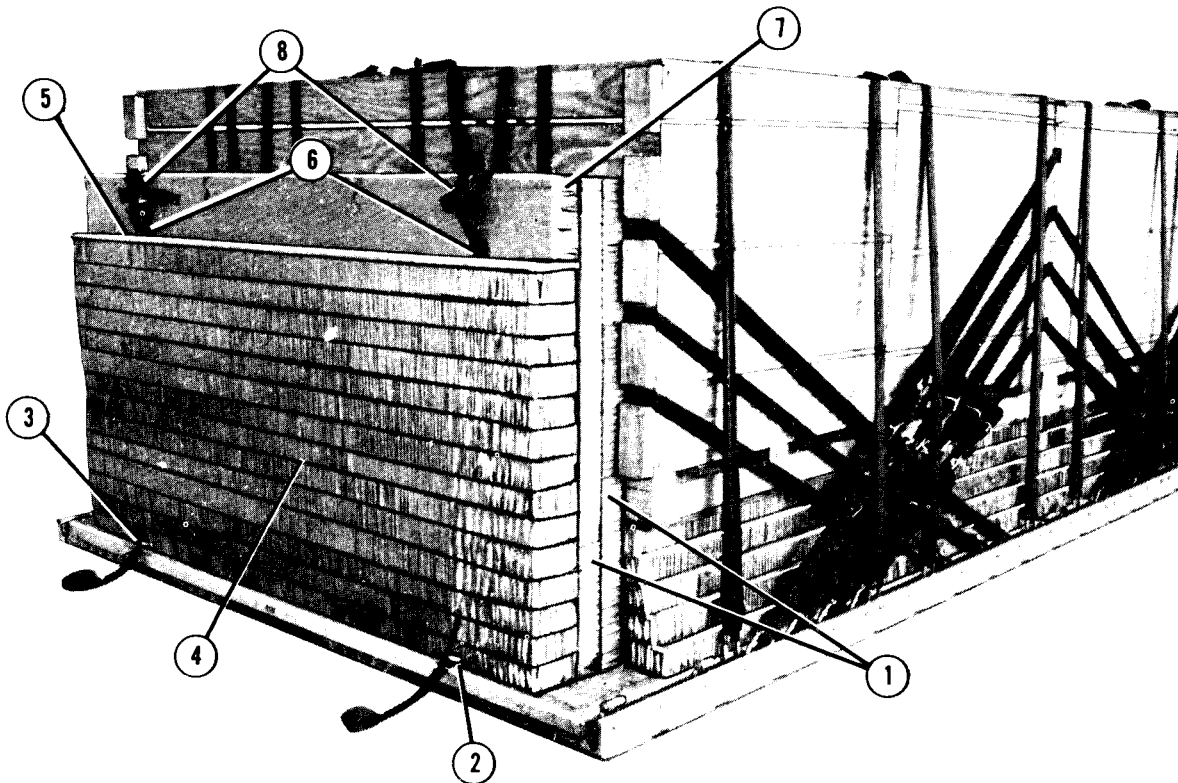

- ① Use two 36- by 88-inch and two 14- by 88-inch pieces of honeycomb to form two 50- by 88-inch honeycomb layers. Position the layers flush against the rear of the first box.
- ② Pass a 16-foot lashing through tiedown ring A16. Roll one end of the lashing, and lay it on top of the 50- by 88-inch honeycomb layers (not shown). Roll the bottom end of the lashing, and lay it at the rear of the platform.
- ③ Repeat step 2 above using tiedown ring D16.
- ④ Stack 14 pieces of 6- by 88-inch honeycomb flush against the items placed in steps 1, 2, and 3.
- ⑤ Place a piece of 3/4- by 6- by 88-inch plywood on top of the honeycomb stacked in step 4 above.
- ⑥ Pass the remaining end of each 16-foot lashing (steps 2 and 3 above) up between the outer layer of 50- by 88-inch honeycomb and the items placed in steps 4 and 5 above (not shown).
- ⑦ Place a piece of 8- by 88-inch honeycomb on top of the plywood placed in step 5 above between the 16-foot lashings and the outer layer of 50- by 88-inch honeycomb.
- ⑧ Fold the remaining end of each 16-foot lashing (steps 2 and 3 above), and tape it to the honeycomb placed in step 7 above.

Figure 4-7. Attitude control bar installed

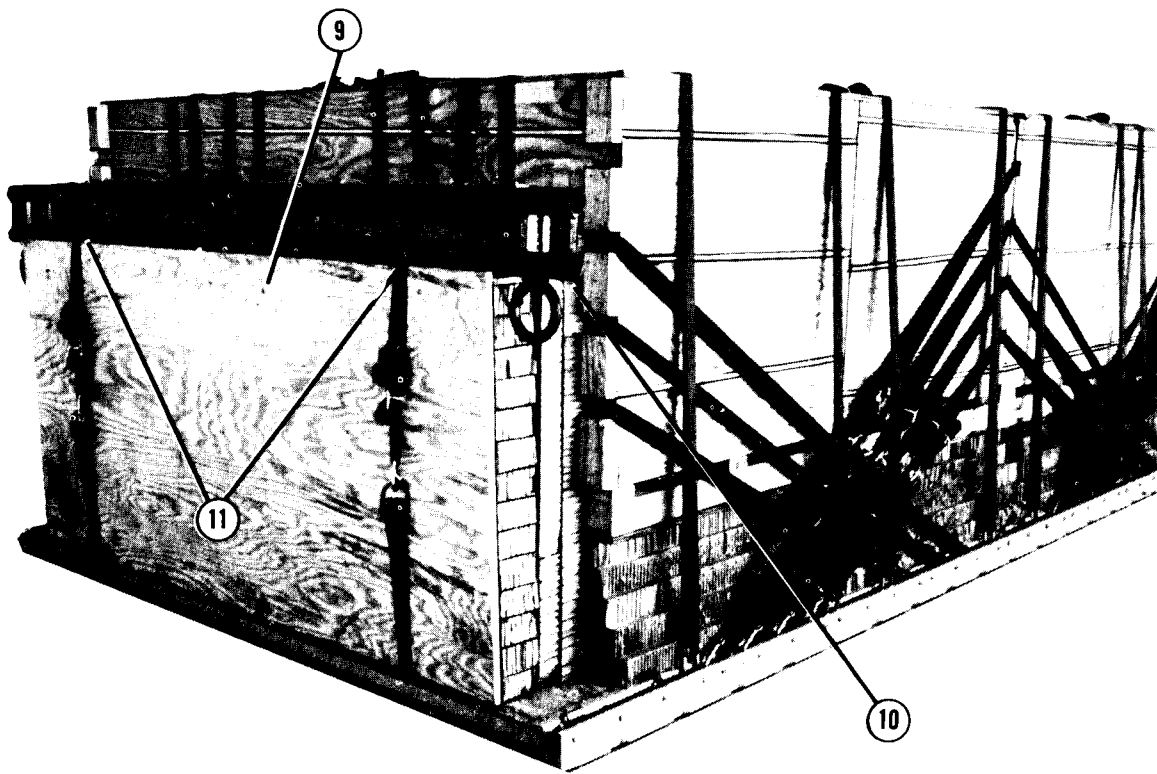

- ⑨ Place a piece of 3/4- by 42- by 88-inch plywood flush against the honeycomb stacked in step 4.
- ⑩ Remove the tape (step 8) from the 16-foot lashings. Position the attitude control bar, with rings down, on top of the plywood placed in step 5 and flush against the honeycomb placed in step 7.
- ⑪ Pass the 16-foot lashings (steps 2 and 3) between the top and bottom bars of the attitude control bar. Bind the lashings.

*Figure 4-7. Attitude control bar installed (continued)*



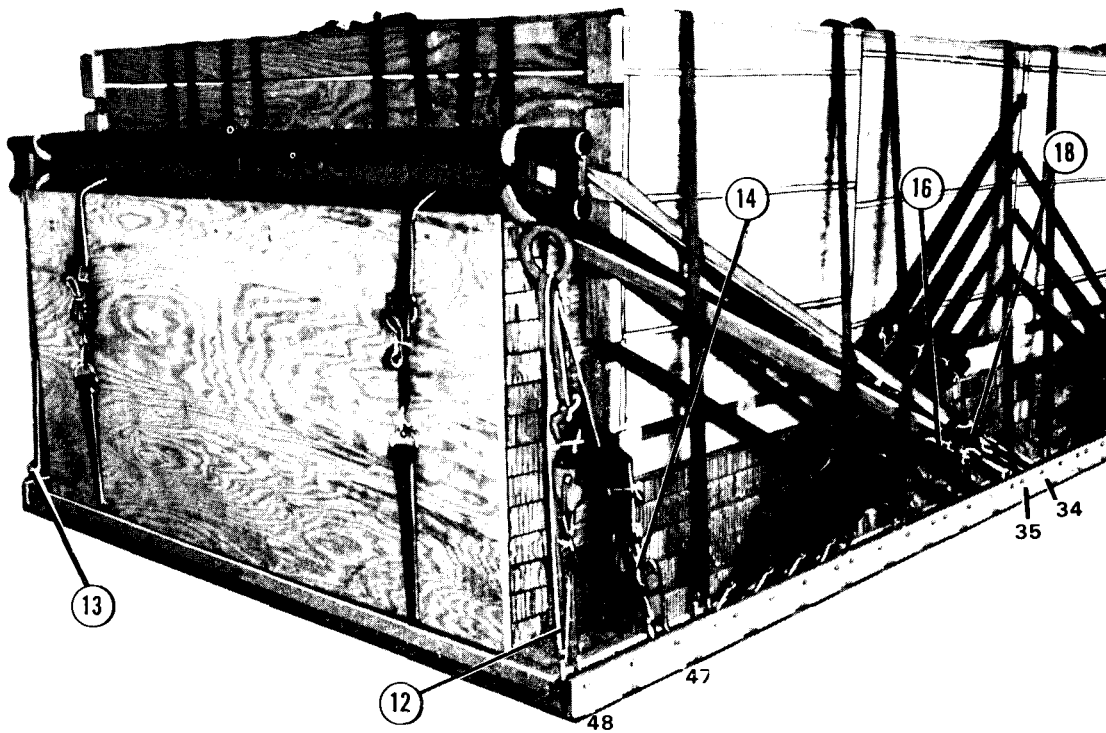

- ⑫ Pass a 16-foot lashing through clevis 48 and the closest ring on the attitude control bar. Bind the lashing.
- ⑬ Repeat step 12 above on the left side of the platform using clevis 48A.
- ⑭ Repeat step 12 above using clevis 47.
- ⑮ Repeat step 12 above on the left side of the platform using clevis 47A (not shown).
- ⑯ Pass a 16-foot lashing through clevis 35 and around the right lower bar of the attitude control bar. Bind the lashing.
- ⑰ Repeat step 16 above on the left side of the platform using clevis 35A (not shown).
- ⑱ Repeat step 16 above using clevis 34 and the right upper bar.
- ⑲ Repeat step 16 above on the left side of the platform using clevis 34A and the upper bar (not shown).

*Figure 4-7. Attitude control bar installed (continued)*

### 4-9. Installing Extraction System

Install the extraction system according to FM 10-500/TO 13C7-1-5 and as shown in Figure 4-8.

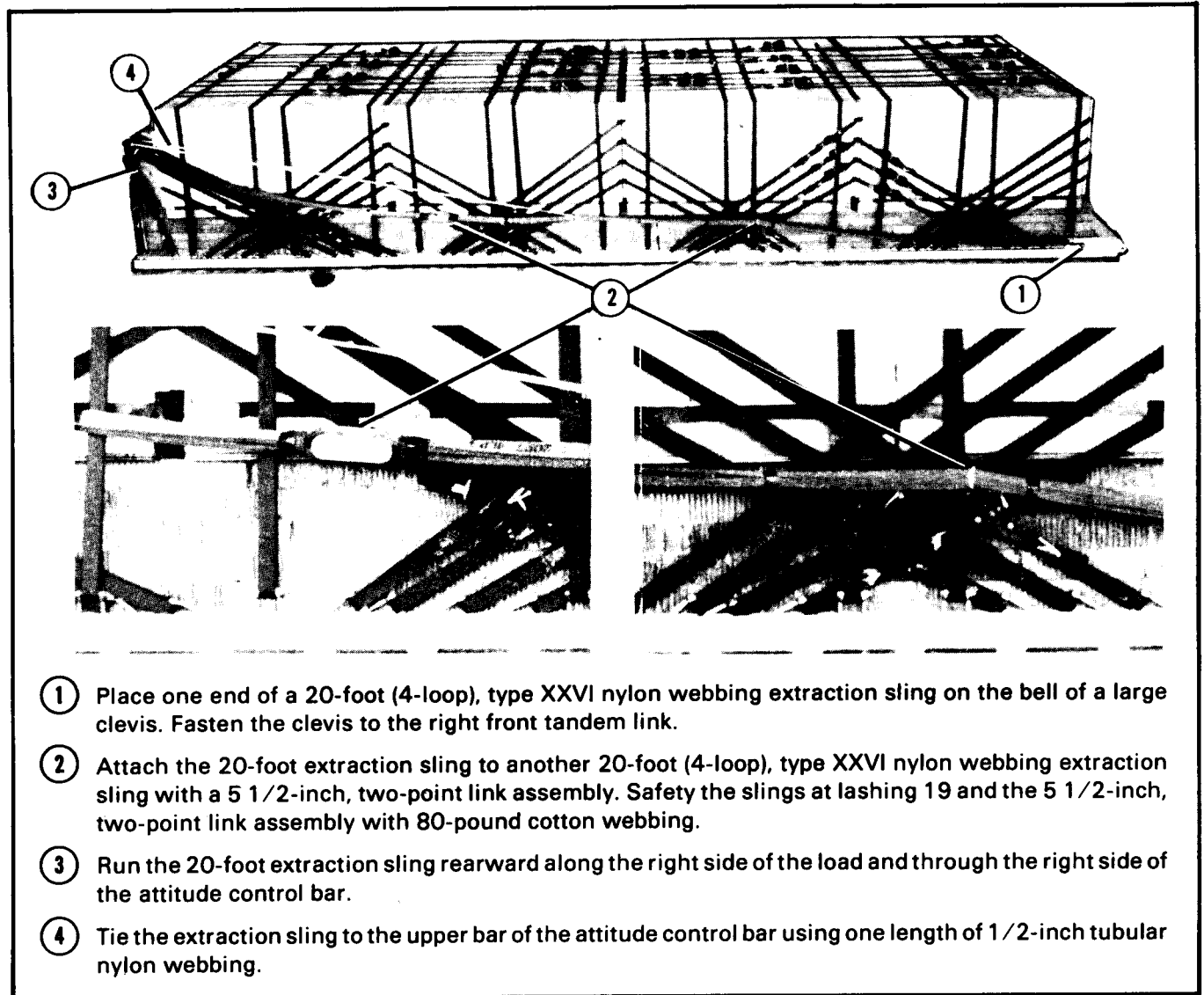

*Figure 4-8. Extraction system installed*

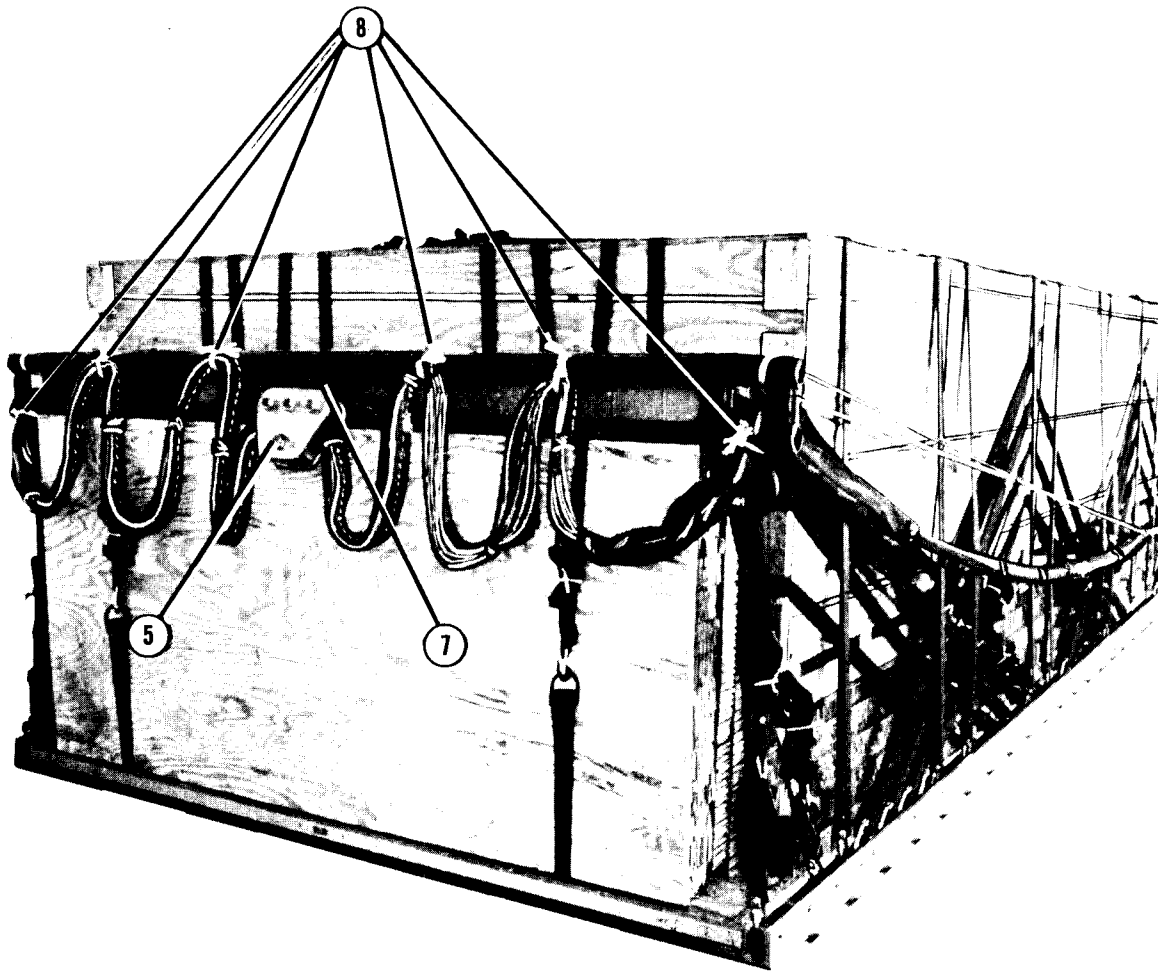

- ⑤ Attach the extraction sling to a four-point link assembly at the rear of the load.
- ⑥ Repeat steps 1 through 5 on the left side of the load (not shown).
- ⑦ Tie the four-point link assembly to the center brace of the attitude control bar with 1-inch tubular nylon webbing.
- ⑧ Fold and tie the extraction slings to the attitude control bar with six ties. Make each tie with five lengths of 80-pound cotton webbing.

*Figure 4-8. Extraction system installed (continued)*

**4-10. Placing Extraction Parachutes**

Place a 15-foot cargo extraction parachute with a 60-foot (1-loop), type XXVI nylon webbing extraction line and two 28-foot cargo extraction parachutes (packed for LAPE) with a 60-foot (6-loop), type XXVI nylon webbing extraction line on the load for installation in the aircraft according to FM 10-500/TO 13C7-1-5.

**4-11. Marking Rigged Load**

Mark the rigged load according to FM 10-500/TO 13C7-1-5 and as shown in Figure 4-9. If the load varies from the one shown in Figure 4-9, the height, weight, CB, and parachute requirements must be recomputed.

- NOTES:**
1. Use a deployment line bag.
  2. Lay a 12- by 12-inch piece of felt or honeycomb on the platform to pad the coupling link assembly in the aircraft.

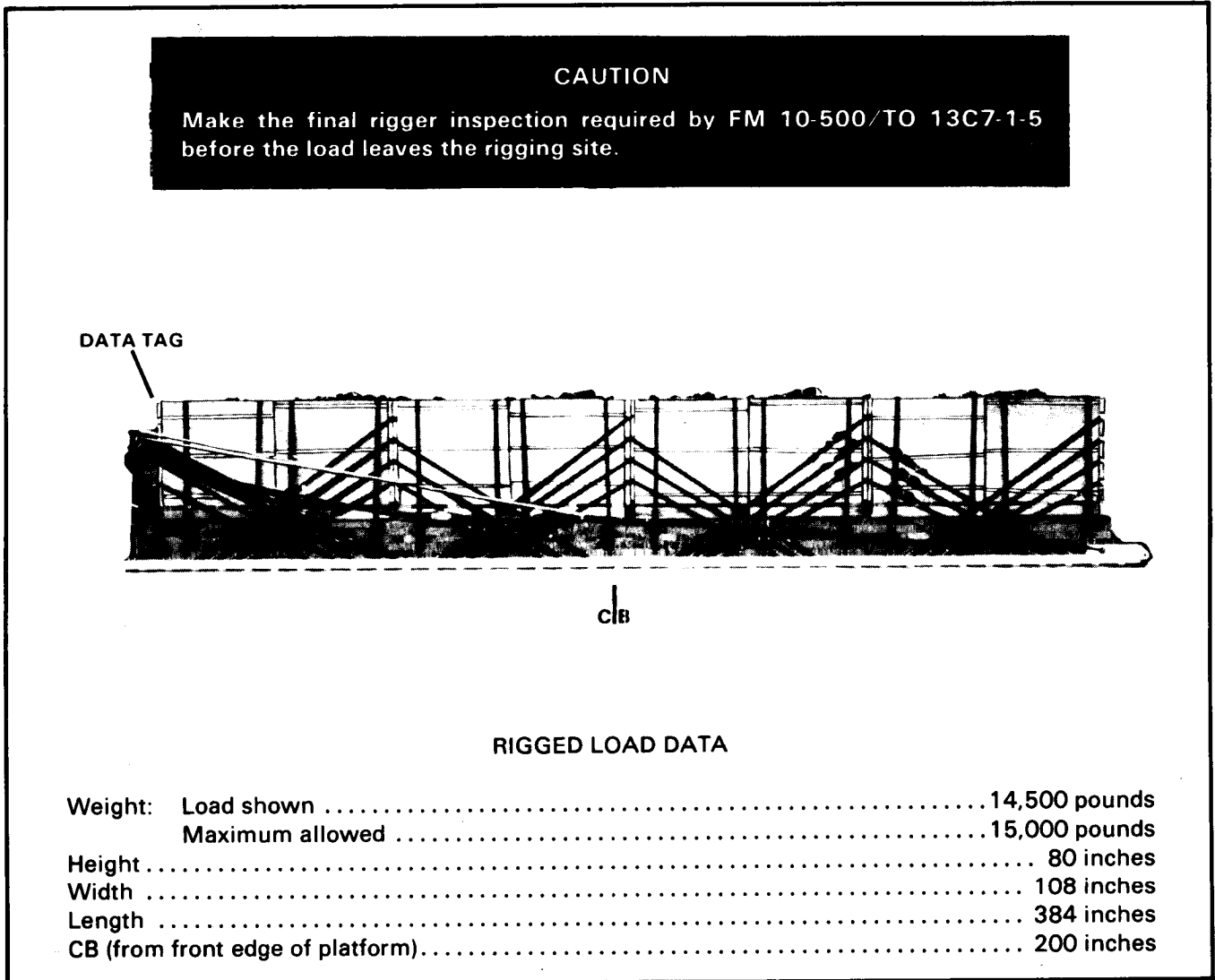

*Figure 4-9. Whole blood rigged for LAPE airdrop on a type V airdrop platform*

**4-12. Equipment Required**

Use the equipment listed in Table 4-1 to rig this load.

*Table 4-1. Equipment required for rigging whole blood for LAPE airdrop on a type V platform*

National Stock Number	Item	Quantity
8040-00-273-8713	Adhesive, paste, 1-gal	As required
1670-00-003-4389	Bar, attitude control	1
3990-00-937-0272	Binder, load, 10,000-lb	74
1670-01-035-6054	Bridle, extraction line bag, use w extraction line leaf	1
4030-00-090-5354	Clevis, suspension, 1-in (large)	2
4020-00-240-2146	Cord, nylon, type III, 550-lb	As required
8135-00-664-6958	Cushioning material, packaging, cellulose wadding	As required
5365-00-937-0147	D-ring, heavy-duty, 10,000-lb	148
8305-00-958-3685	Felt, 1/2-in thick	As required
1670-01-183-2678	Leaf, extraction line (line bag)	2
	Line, extraction, type XXVI nylon webbing:	
1670-01-064-4452	60-ft (1-loop)	1
1670-00-003-1957	60-ft (6-loop)	1
	Link assembly:	
1670-01-072-1378	Extraction (LAPE)	1
1670-00-006-2752	Four-point	1
	Two-point:	2
5306-00-435-8994	Bolt, 1-in diam, 4-in long	(4)
5310-00-232-5165	Nut, 1-in	(4)
1670-00-003-1954	Plate, side, 5 1/2-in	(4)
5365-00-007-3414	Spacer, large	(4)
1670-00-783-5988	Type IV	1
5510-00-220-6146	Lumber, 2- by 4-in:	
	6-in	64
	7 1/2-in	16
	42-in	16
	86-in	16
	95 1/2-in	24
5510-00-220-6274	Lumber, 4- by 4- by 43 1/2-in	40
	Nail, steel wire, common:	
5315-00-162-3151	4d	As required
5315-00-010-4657	6d	As required
5315-00-010-4659	8d	As required
5315-00-010-4661	10d	As required
1670-00-753-3928	Pad, energy-dissipating, honeycomb,	
	3- by 36- by 96-in:	46 sheets
	2- by 94-in	(160)
	4- by 90 1/2-in	(12)
	6- by 88-in	(14)
	6- by 90 1/2-in	(12)
	6- by 94-in	(16)
	8- by 80-in	(6)
	8- by 81-in	(6)

Table 4-1. Equipment required for rigging whole blood for LAPE airdrop on a type V platform  
(continued)

National Stock Number	Quantity	Item
	8- by 88-in	(1)
	10- by 90 1/2-in	(12)
	12- by 12-in	(1)
	12- by 90 1/2-in	(12)
	14- by 88-in	(2)
	36- by 88-in	(2)
	36- by 94-in	(16)
	91 1/2- by 8-in	(5)
	Parachute, cargo extraction:	
1670-00-052-1548	15-ft <i>or</i>	1
1670-01-063-3715	15-ft	1
1670-00-262-1797	28-ft (packed for LAPE) <i>or</i>	2
1670-00-040-8135	28-ft, heavy-duty (packed for LAPE)	2
	Platform, airdrop, type V, 32-ft:	1
1670-01-162-2385	Bumper, nose	(1)
1670-01-162-2372	Clevis, load tiedown	(96)
1670-01-162-2381	Tandem link	(2)
5530-00-128-4981	Plywood, 3/4-in:	
	6- by 88-in	1
	39 1/2- by 42-in	16
	39 1/2- by 95 1/2-in	16
	42- by 88-in	1
	42- by 94-in	8
	43 1/2- by 95 1/2-in	8
1670-01-064-4453	Sling, cargo, airdrop, extraction, 20-ft (4-loop), type XXVI nylon webbing	4
8135-00-283-0667	Strapping, steel, 5/8-in	As required
7510-00-266-5016	Tape, adhesive, 2-in	As required
	Webbing:	
8305-00-268-2411	Cotton, 80-lb	As required
8305-00-082-5752	Nylon, tubular, 1/2-in, 1,000-lb, natural	As required
8305-00-268-2455	Nylon, tubular, 1-in, 4,000-lb, olive drab	As required
8305-00-263-3591	Nylon, type VIII, 3,600-lb	As required
8305-00-261-8584	Nylon, type X, treated, 8,700-lb, olive drab	As required

## CHAPTER 5

**RIGGING WHOLE BLOOD IN A-7A, A-21, AND A-22  
CONTAINERS FOR LOW-VELOCITY AIRDROP**

---

## Section I

**RIGGING ONE BLOOD CONTAINER IN AN A-7A OR A-21  
CONTAINER FOR DOOR DROP****5-1. Description of Load**

Whole blood is rigged in a two-strap, A-7A container. The load is rigged on a skid board and two layers of honeycomb.

**NOTE: If an A-7A container is unavailable, substitute an A-21 container. Secure the container according to FM 10-501/TO 13C7-1-11.**

**5-2. Packing Blood in  
Cardboard Container**

Pack whole blood in a cardboard container as described in paragraph 2-6. Only one container is required for this load.

**5-3. Rigging Load**

Rig one blood container as shown in Figure 5-1.

**CAUTION**

**Make sure the load meets the 28-pounds-per-square-foot requirement according to FM 10-501/TO 13C7-1-11.**

**5-4. Stowing Cargo Parachutes**

Weigh the rigged blood container. Select, pack, and stow the correct cargo parachutes for this load as described in FM 10-502/TO 13C7-1-11.

**NOTES:**

1. This drawing is not drawn to scale.
2. All holes are 1/2 inch in diameter.

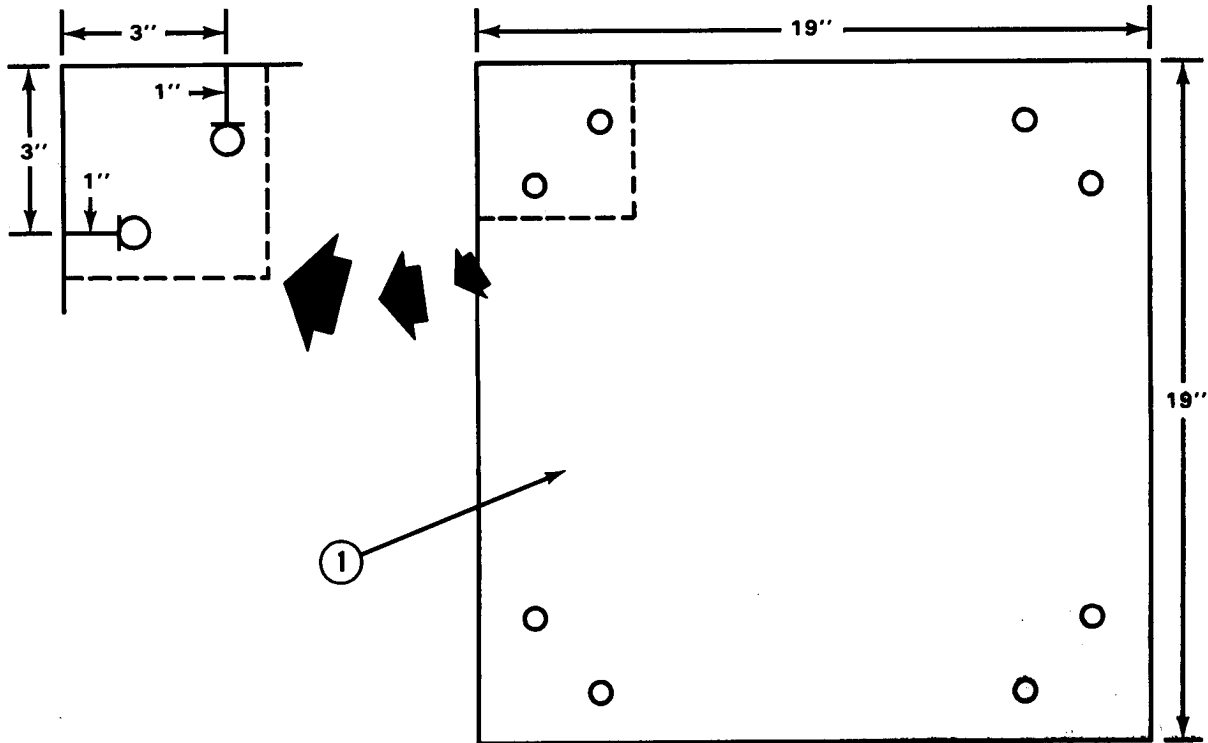

- ① Prepare a skid board as shown using 1/2-inch plywood.

*Figure 5-1. One blood container rigged*



NOTE: This drawing is not drawn to scale.

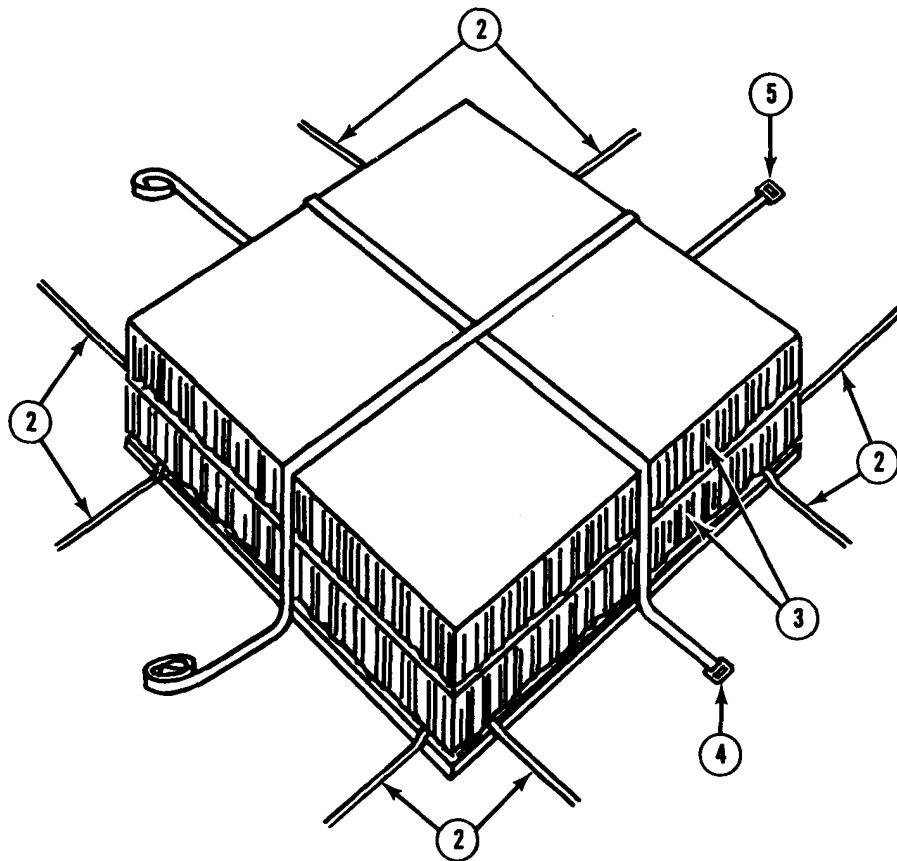

- ② Pass one 3-foot length of type III nylon cord through each set of holes in each corner of the skid board.
- ③ Cut two 19- by 19-inch pieces of honeycomb, and glue them together forming two layers. Glue the honeycomb to the skid board.

**CAUTION**

Make sure the honeycomb is glued to the skid board to prevent the blood container from sliding off the pallet upon impact and causing damage to the Styrofoam container.

- ④ Lay one A-7A strap across the center of the honeycomb. Make sure the large lip portion of the friction adapter is down.
- ⑤ Lay a second A-7A strap across the opposite side of the honeycomb in the center. Make sure the lip portion of the friction adapter is down.

Figure 5-1. One blood container rigged (continued)

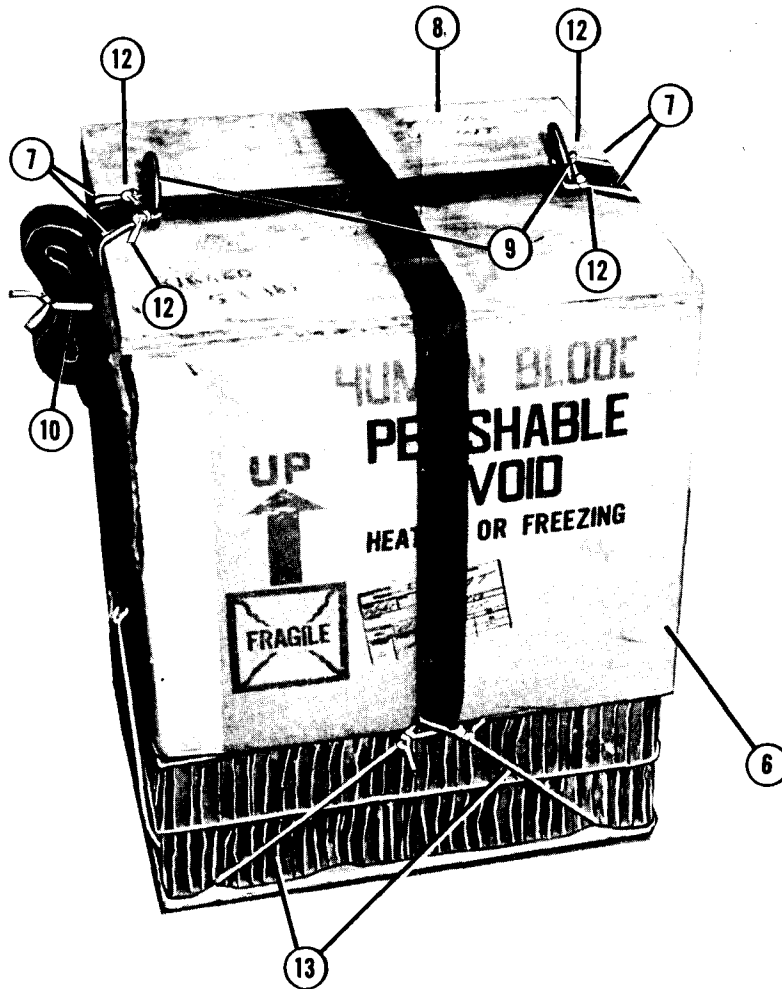

- ⑥ Place one blood container on top of the A-7A straps and the honeycomb.
- ⑦ Center two 3-foot lengths of type III nylon cord side by side on top of the blood container.
- ⑧ Place a piece of 1/2- by 19- by 19-inch plywood on top of the type III nylon cord and the blood container.
- ⑨ Slide two D-rings on the end strap. Pass the free end of the strap over the top of the load. Position the D-rings on top of the load.
- ⑩ Fasten the end strap with its friction adapter. Fold the excess strap, and secure the folds to its strap with 80-pound cotton webbing.
- ⑪ Pass the free end of the side strap over the top of the load. Fasten the side strap with its friction adapter. Fold the excess strap, and secure the folds to its strap with 80-pound cotton webbing (not shown).
- ⑫ Fasten the two D-rings in place using the type III nylon cord positioned in step 7 above.
- ⑬ Fasten the skid board to the straps using the type III nylon cord positioned in step 2.

Figure 5-1. One blood container rigged (continued)

**5-5. Marking Rigged Load**

Mark the rigged load according to FM 10-501/TO 13C7-1-11. The rigged load data must be computed for this load. The rigged weight range for this load is 75 to 100 pounds.

**CAUTION**

Make the final rigger inspection required by FM 10-501/TO 13C7-1-11 before the load leaves the rigging site.

**5-6. Equipment Required**

Use the equipment listed in Table 5-1 to rig this load.

*Table 5-1. Equipment required for rigging one blood container for low-velocity airdrop in an A-7A container*

National Stock Number	Item	Quantity
8040-00-273-8713	Adhesive, paste, 1-gal	As required
4020-00-240-2146	Cord, nylon, type III, 550-lb	As required
1670-00-753-3928	Pad, energy-dissipating, honeycomb, 3- by 36- by 96-in:	1 sheet
5530-00-129-7777	19- by 19-in	(2)
1670-00-251-1153	Parachute, cargo	As required
7510-00-266-5016	Plywood, 1/2- by 19- by 19-in	2
8305-00-268-2411	*Sling assembly, cargo, airdrop, A-7A	1
	Tape, adhesive, 2-in	As required
	Webbing, cotton, 80-lb	As required

\*If the A-7A sling assembly is not available, use the A-21 cargo bag (NSN 1670-00-242-9173).

Section II

**RIGGING TWO BLOOD CONTAINERS IN AN A-7A OR A-21 CONTAINER FOR DOOR DROP**

**5-7. Description of Load**

Whole blood is rigged in a three-strap, A-7A container. The load is rigged on a skid board and two layers of honeycomb.

**NOTE: If an A-7A container is unavailable, substitute an A-21 container. Secure the container according to FM 10-501/TO 13C7-1-11.**

**5-8. Packing Blood in Cardboard Containers**

Pack whole blood in cardboard containers as described in paragraph 2-6. Two containers are required for this load.

**5-9. Rigging Load**

Rig two blood containers as shown in Figure 5-2.

**CAUTION**  
 Make sure the load meets the 28-pounds-per-square-foot requirement according to FM 10-501/TO 13C7-1-11.

**5-10. Stowing Cargo Parachutes**

Weigh the rigged blood containers. Select, pack, and stow the correct cargo parachutes for this load as described in FM 10-501/TO 13C7-1-11.

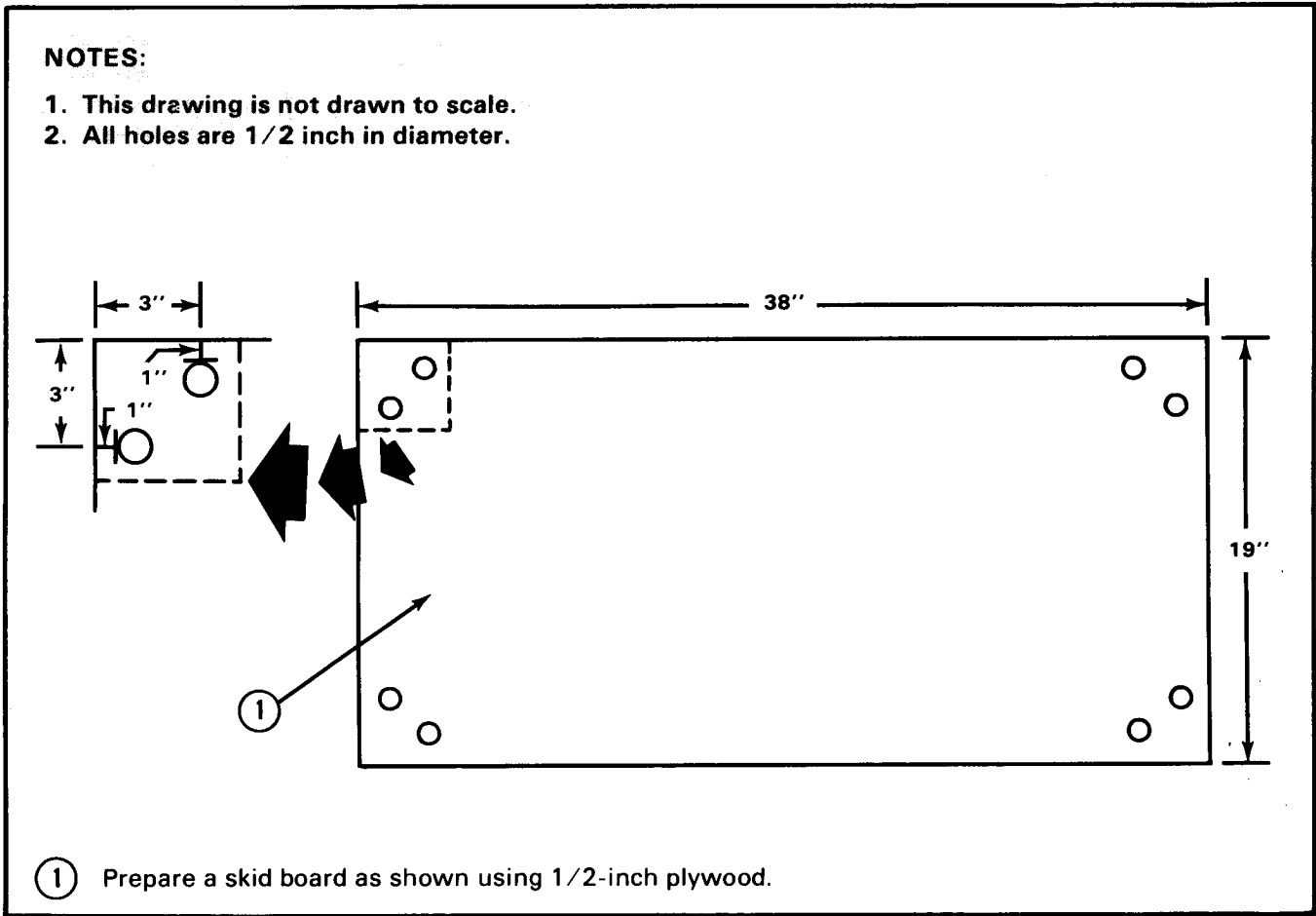
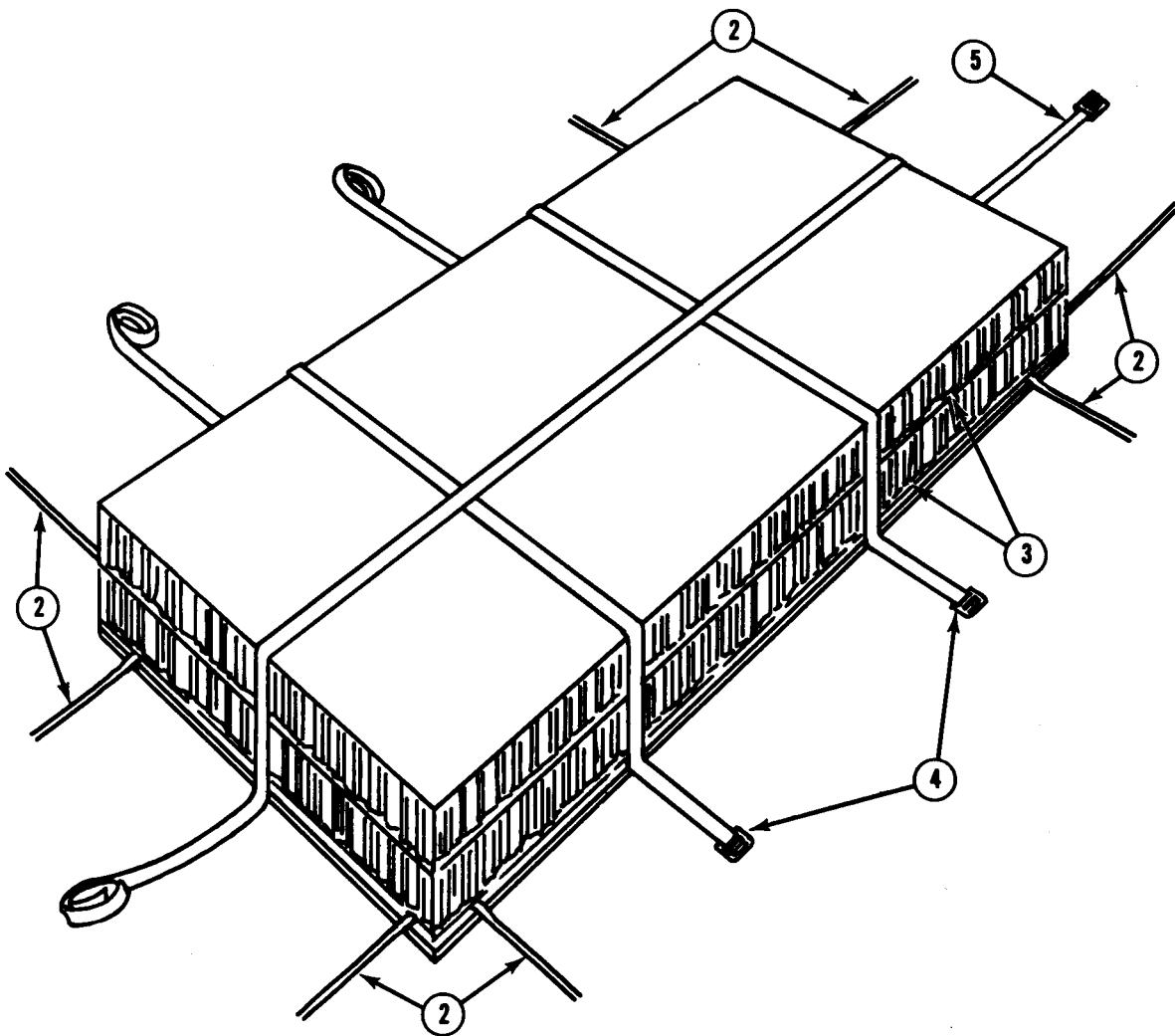

Figure 5-2. Two blood containers rigged

**NOTE:** This drawing is not drawn to scale.



- ② Pass one 3-foot length of type III nylon cord through each set of holes in each corner of the skid board.
- ③ Cut two 19- by 38-inch pieces of honeycomb, and glue them together forming two layers. Glue the honeycomb to the skid board.

**CAUTION**

Make sure the honeycomb is glued to the skid board to prevent the blood containers from sliding off the pallet upon impact and causing damage to the Styrofoam containers.

- ④ Place two A-7A straps across the 38-inch sides of the honeycomb with the straps parallel to each other (16 inches apart). Make sure the lip portions of the friction adapters are down.
- ⑤ Lay a third A-7A strap across the opposite sides of the honeycomb in the center.

*Figure 5-2. Two blood containers rigged (continued)*

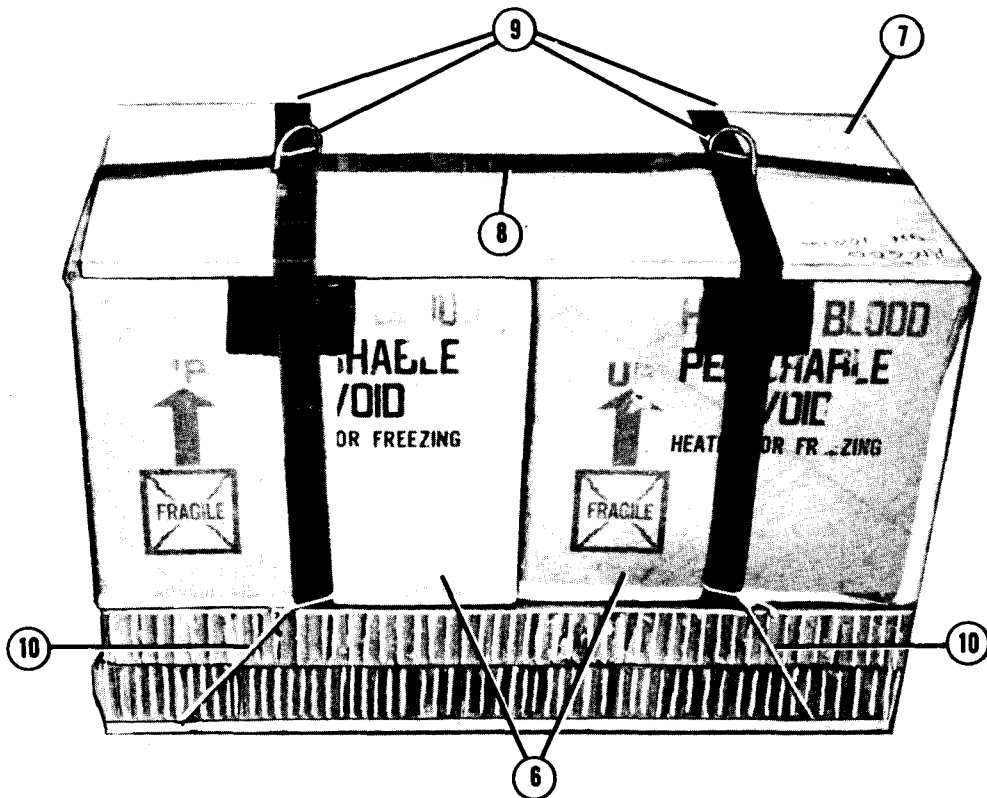

- ⑥ Place two blood containers on top of the A-7A straps and the honeycomb.
- ⑦ Place a piece of 1/2- by 19- by 38-inch plywood on top of the blood containers.
- ⑧ Slide two D-rings on the end strap. Pass the free end of the strap over the top of the load. Position the D-rings on top of the load. Fasten the end strap with its friction adapter. Fold the excess strap, and secure the folds to its strap with 80-pound cotton webbing.
- ⑨ Pass the right A-7A strap over the top of the load through the right D-ring. Pass the left A-7A strap over the top of the load through the left D-ring. Fasten each strap with its own friction adapter. Fold the excess strap, and secure the folds to its strap with 80-pound cotton webbing.
- ⑩ Fasten the skid board to the straps using the type III nylon cord positioned in step 2.

*Figure 5-2. Two blood containers rigged (continued)*

**5-11. Marking Rigged Load**

Mark the rigged load according to FM 10-501/TO 13C7-1-11. The rigged load data must be computed for this load. The rigged weight range for this load is 150 to 175 pounds.

**CAUTION**

Make the final rigger inspection required by FM 10-501/TO 13C7-1-11 before the load leaves the rigging site.

**5-12. Equipment Required**

Use the equipment listed in Table 5-2 to rig this load.

*Table 5-2. Equipment required for rigging two blood containers for low-velocity airdrop in an A-7A container*

National Stock Number	Item	Quantity
8040-00-273-8713	Adhesive, paste, 1-gal	As required
4020-00-240-2146	Cord, nylon, type III, 550-lb	As required
1670-00-753-3928	Pad, energy-dissipating, honeycomb, 3- by 36- by 96-in: 19- by 38-in	1 sheet (2)
5530-00-129-7777	Parachute, cargo	As required
1670-00-251-1153	Plywood, 1/2- by 19- by 38-in	2
7510-00-266-5016	*Sling assembly, cargo, airdrop, A-7A	1
8305-00-268-2411	Tape, adhesive, 2-in	As required
	Webbing, cotton, 80-lb	As required

\*If the A-7A sling assembly is not available, use the A-21 cargo bag (NSN 1670-00-242-9173).

Section III

**RIGGING FOUR BLOOD CONTAINERS IN AN A-7A OR A-21 CONTAINER FOR DOOR DROP**

**5-13. Description of Load**

Whole blood is rigged in a three-strap, A-7A container. The load is rigged on a skid board and two layers of honeycomb.

**NOTE:** If an A-7A container is unavailable, substitute an A-21 container. Secure the container according to FM 10-501/TO 13C7-1-11.

**5-14. Packing Blood in Cardboard Containers**

Pack whole blood in cardboard containers as described in paragraph 2-6. Four containers are required for this load.

**5-15. Rigging Load**

Rig four blood containers as shown Figure 5-3.

**CAUTION**

Make sure the load meets the 28-pounds-per-square-foot requirement according to FM 10-501/TO 13C7-1-11.

**5-16. Stowing Cargo Parachutes**

Weigh the rigged blood container. Select, pack, and stow the correct cargo parachutes for this load as described in FM 10-501/TO 13C7-1-11.

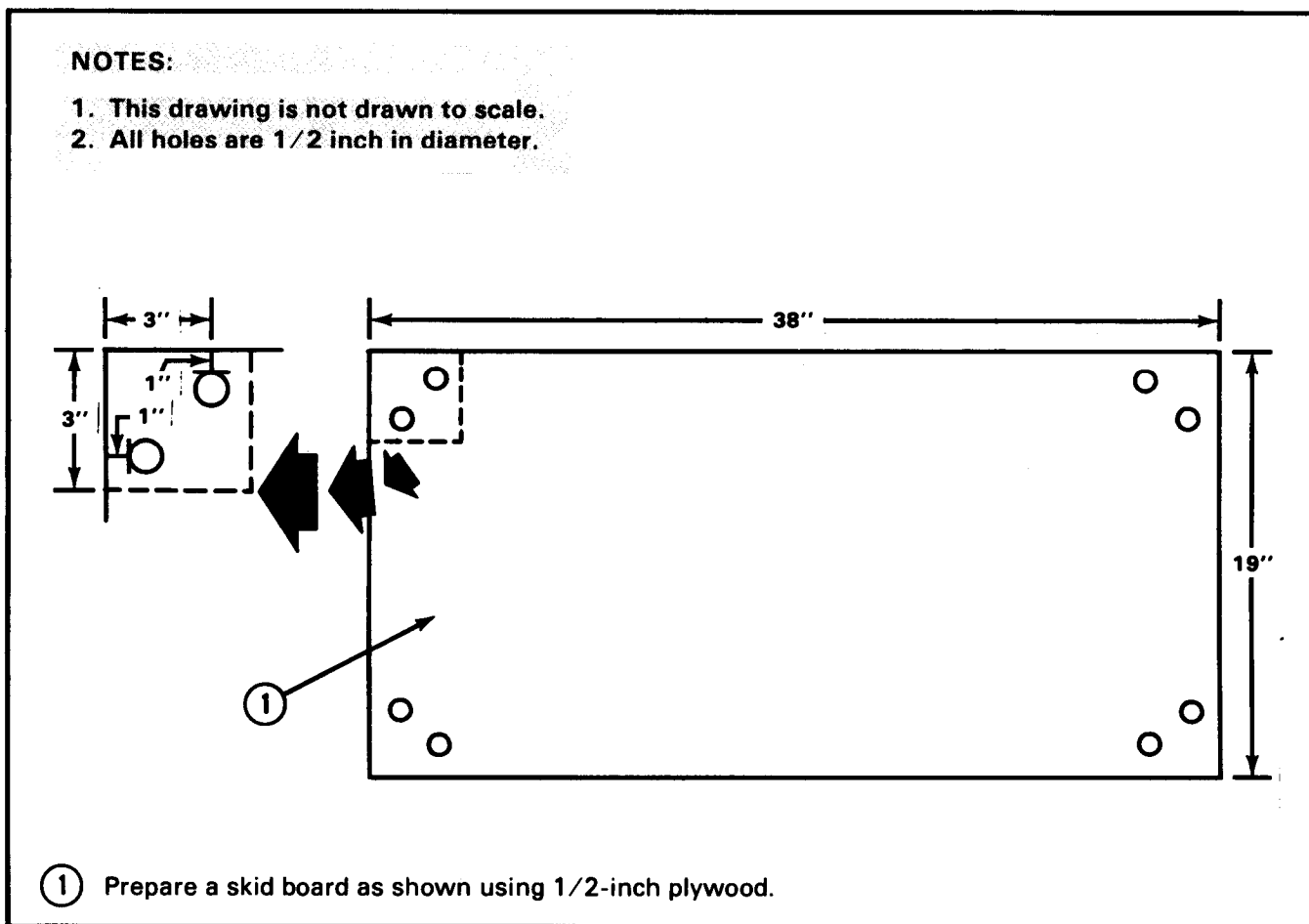
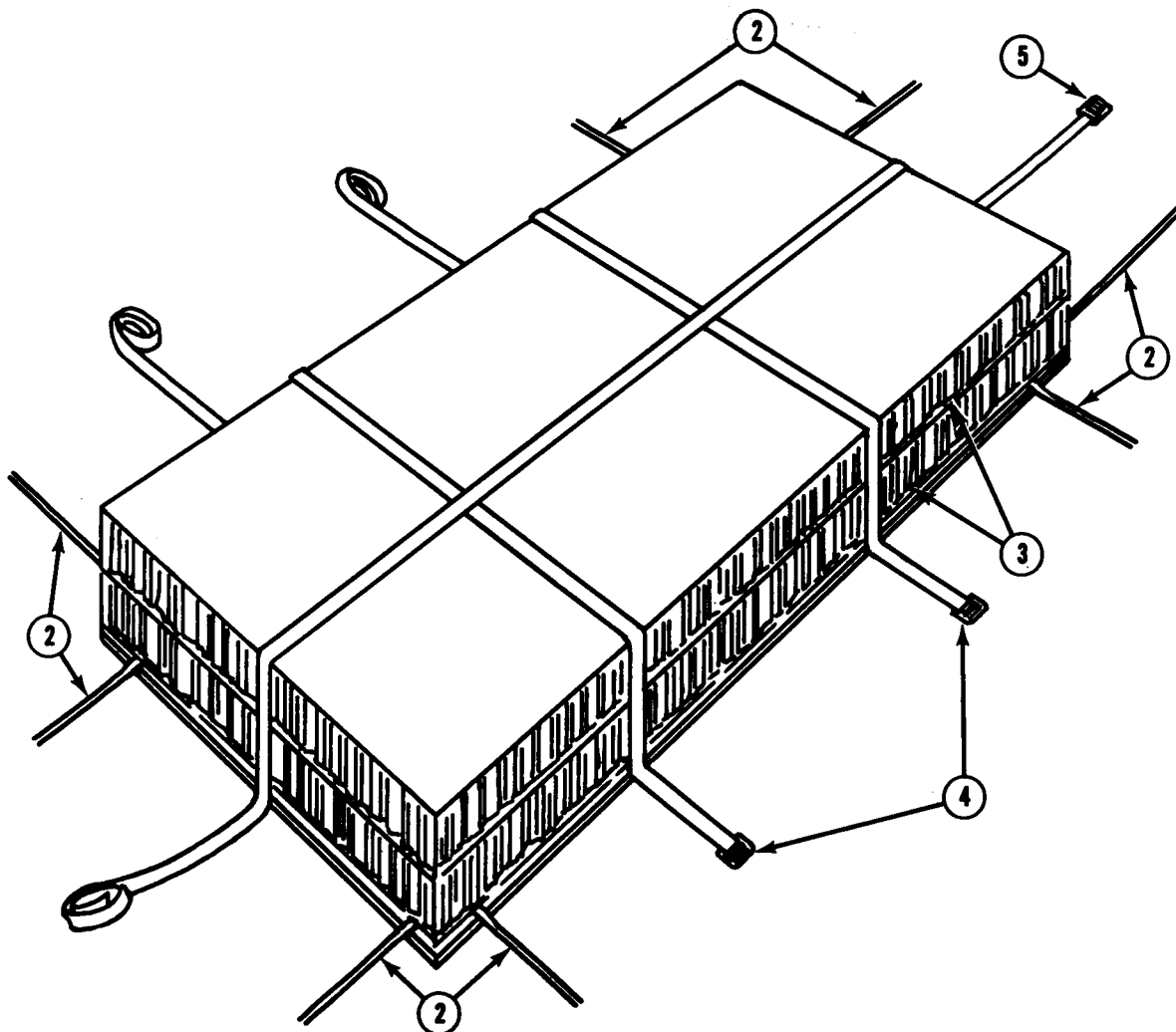

Figure 5-3. Four blood containers rigged



**NOTE:** This drawing is not drawn to scale.



- ② Pass one 3-foot length of type III nylon cord through each set of holes in each corner of the skid board.
- ③ Cut two 19- by 38-inch pieces of honeycomb, and glue them together forming two layers. Glue the honeycomb to the skid board.

**CAUTION**

**Make sure the honeycomb is glued to the skid board to prevent the blood containers from sliding off the pallet upon impact and causing damage to the Styrofoam containers.**

- ④ Place two A-7A straps across the 38-inch sides of the honeycomb with the straps parallel to each other (16 inches apart). Make sure the lip portions of the friction adapters are down.
- ⑤ Lay a third A-7A strap across the opposite sides of the honeycomb in the center.

*Figure 5-3. Four blood containers rigged (continued)*

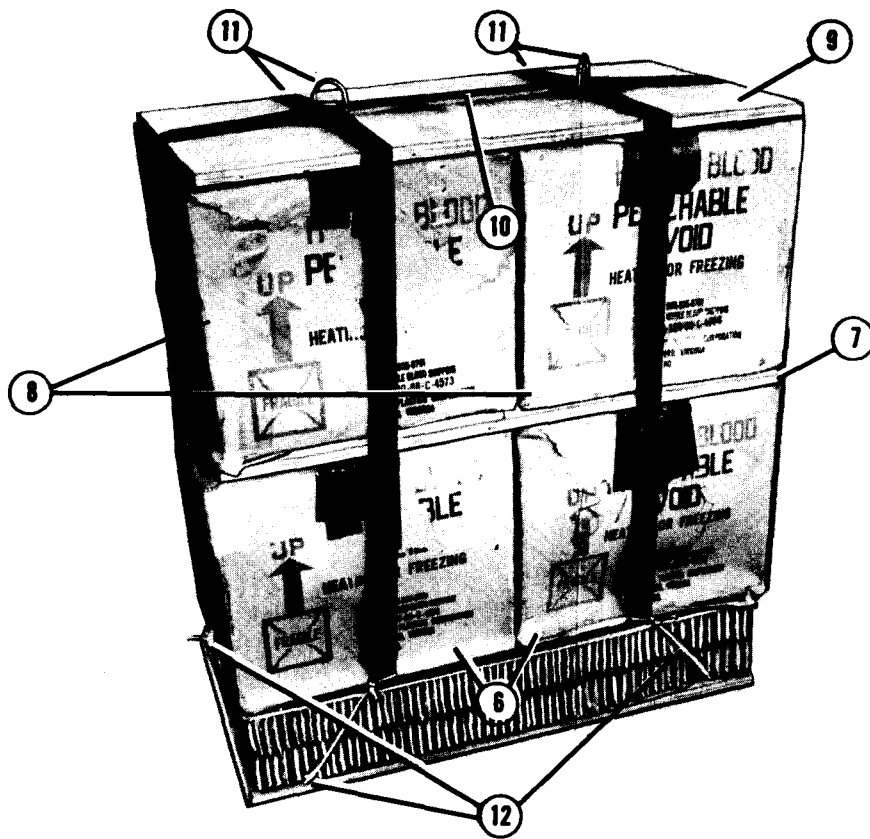

- ⑥ Place two blood containers on top of the A-7A straps and the honeycomb.
- ⑦ Place a piece of 1/2- by 19- by 38-inch plywood on top of the bottom two blood containers.
- ⑧ Place two additional blood containers on top of the plywood.
- ⑨ Place a piece of 1/2- by 19- by 38-inch plywood on top of the blood containers.
- ⑩ Slide two D-rings on the end strap. Pass the free end of the strap over the top of the load. Position the D-rings on top of the load. Fasten the end strap with its friction adapter. Fold the excess strap, and secure the folds to its strap with 80-pound cotton webbing.
- ⑪ Pass the right A-7A strap over the top of the load through the right D-ring. Pass the left A-7A strap over the top of the load through the left D-ring. Fasten each strap with its own friction adapter. Fold the excess strap, and secure the folds to its strap with 80-pound cotton webbing.
- ⑫ Fasten the skid board to the straps using the type III nylon cord positioned in step 2.

*Figure 5-3. Four blood containers rigged (continued)*

**5-17. Marking Rigged Load**

Mark the rigged load according to FM 10-501/TO 13C7-1-11. The rigged load data must be computed for this load. The rigged weight range for this load is 290 to 300 pounds.

**CAUTION**

Make the final rigger inspection required by FM 10-501/TO 13C7-1-11 before the load leaves the rigging site.

**5-18. Equipment Required**

Use the equipment listed in Table 5-3 to rig this load.

*Table 5-3. Equipment required for rigging four blood containers for low-velocity airdrop in an A-7A container*

National Stock Number	Item	Quantity
8040-00-273-8713	Adhesive, paste, 1-gal	As required
4020-00-240-2146	Cord, nylon, type III, 550-lb	As required
1670-00-753-3928	Pad, energy-dissipating, honeycomb, 3- by 36- by 96-in: 19- by 38-in	1 sheet (2)
5530-00-129-7777	Parachute, cargo	As required
1670-00-251-1153	Plywood, 1/2- by 19- by 38-in	3
7510-00-266-5016	*Sling assembly, cargo, airdrop, A-7A	1
8305-00-268-2411	Tape, adhesive, 2-in	As required
	Webbing, cotton, 80-lb	As required

\*If the A-7A sling assembly is not available, use the A-21 cargo bag (NSN 1670-00-242-9173).

**Section IV**

**RIGGING TWELVE BLOOD CONTAINERS IN  
AN A-22 CONTAINER**

**CAUTION**

**See FM 10-501/TO 13C7-1-11 for CVR  
information and procedures.**

**5-19. Description of Load**

Whole blood is rigged in an A-22 container. The load is rigged with one G-12D or G-12E cargo parachute. This load may be rigged for NEACDS according to FM 10-538/TO 13C7-1-18 and for HSSLADS according to FM 10-542/TO 13C7-51-21.

**5-20. Packing Blood in  
Cardboard Containers**

Pack whole blood in cardboard containers as described in paragraph 2-6. Twelve containers are required for this load.

**5-21. Rigging Load**

Rig twelve blood containers as shown in Figure 5-4.

**CAUTION**

**Make sure the load meets the 28-pounds-per-  
square-foot requirement according to  
FM 10-501/TO 13C7-1-11.**

**NOTES:**

1. This drawing is not drawn to scale.
2. All holes are 1/2 inch in diameter.

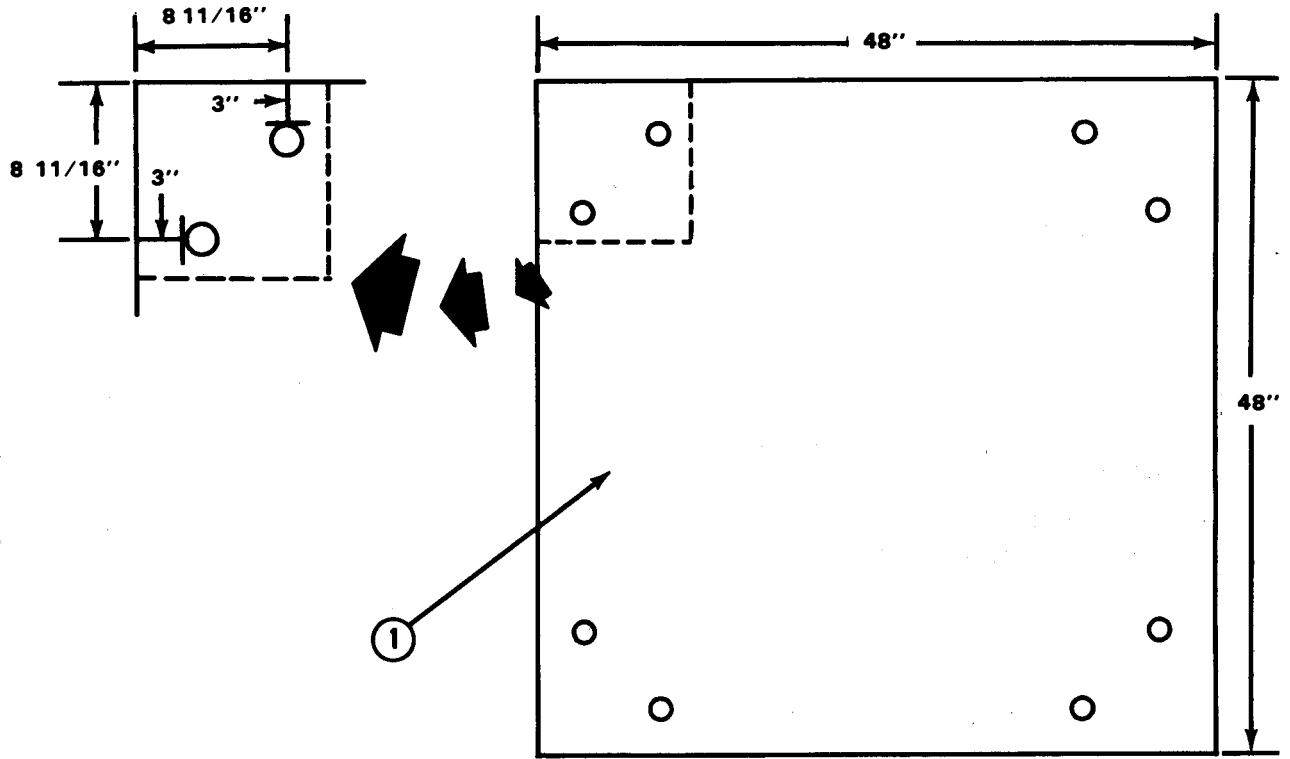

- ① Prepare a skid board as shown using 3/4-inch plywood.

*Figure 5-4. Twelve blood containers rigged*

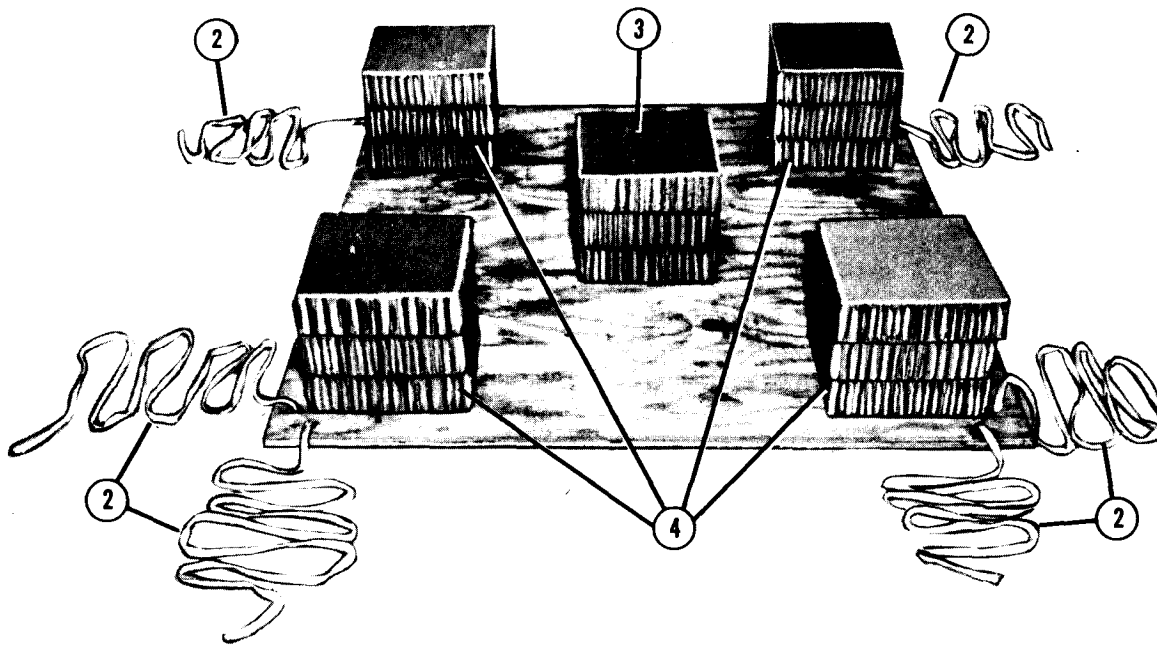

- ② Pass one 10-foot length of 1/2-inch tubular nylon webbing through each set of holes in each corner of the skid board.
- ③ Cut three 10- by 10-inch pieces of honeycomb, and glue them together forming three layers. Glue the honeycomb in the center of the skid board.
- ④ Cut twelve 10- by 10-inch pieces of honeycomb, and glue them together forming four stacks of three layers each. Glue one stack in each corner of the skid board 4 inches from each of its sides.

*Figure 5-4. Twelve blood containers rigged (continued)*

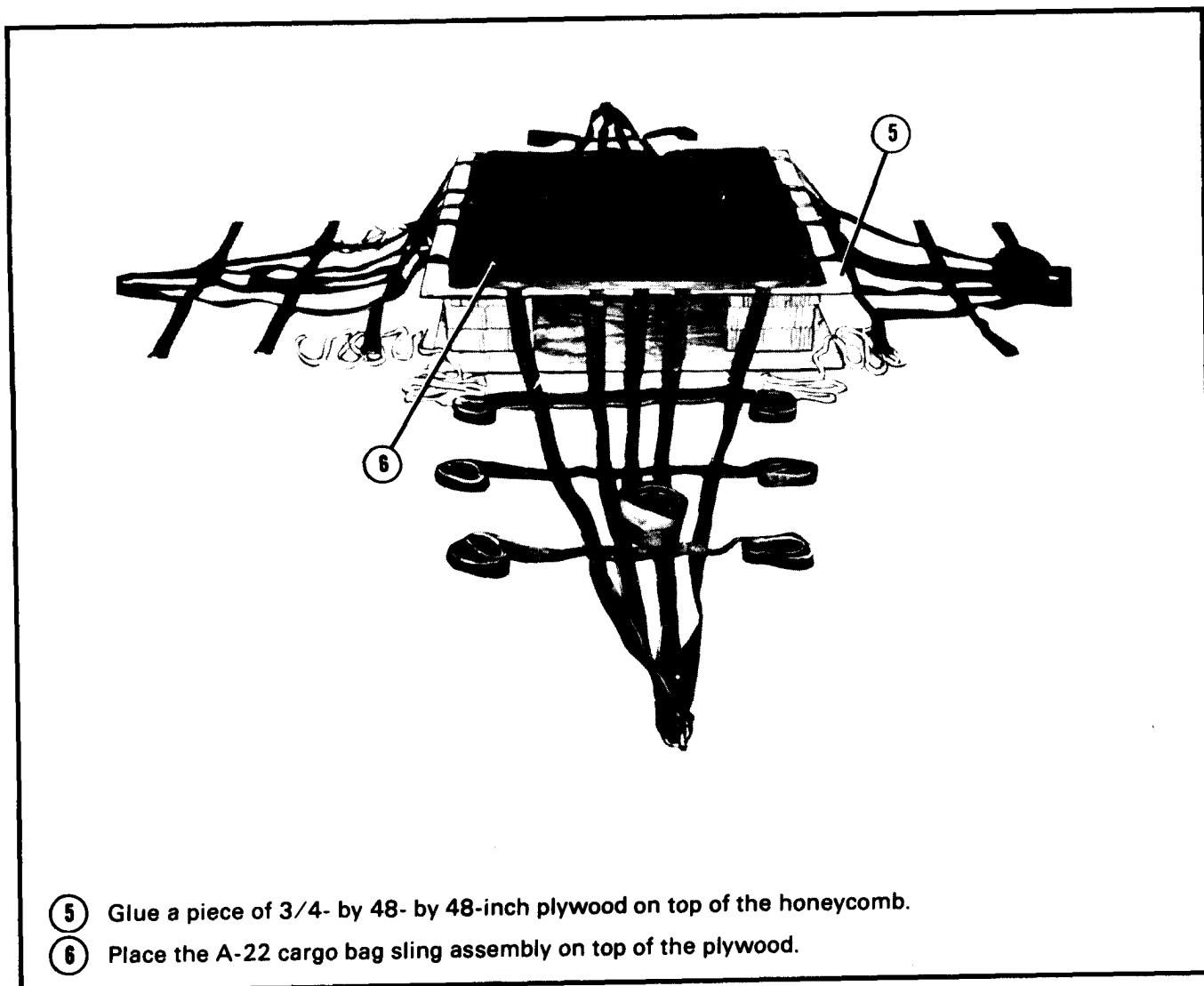

*Figure 5-4. Twelve blood containers rigged (continued)*

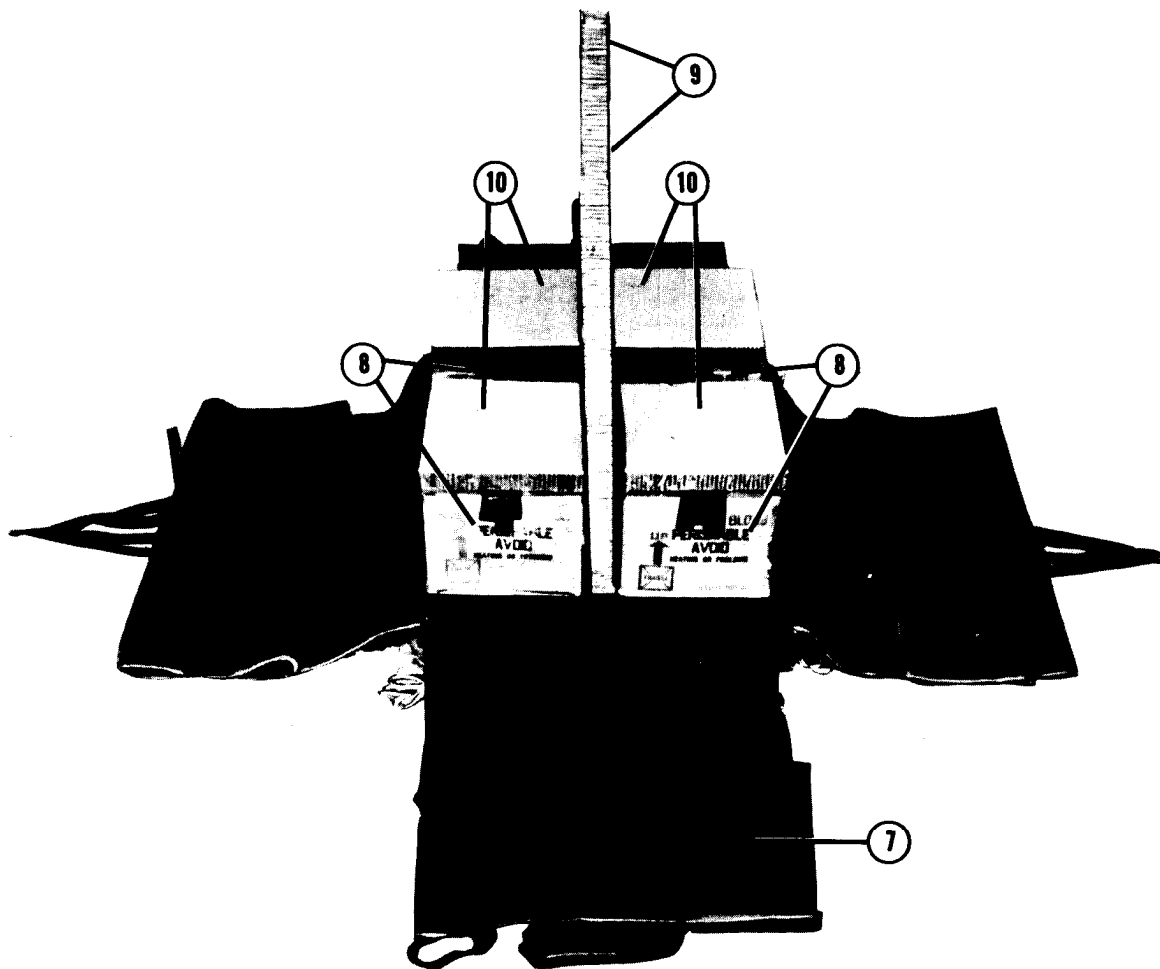

- ⑦ Center the A-22 cargo bag cover on the sling assembly.
- ⑧ Place four blood containers on top of the cover. Position one container in each corner of the plywood (step 5) 3 inches from each of its sides.
- ⑨ Tape a 36- by 54-inch piece of honeycomb to a 5- by 54-inch piece of honeycomb forming one 41- by 54-inch layer. Place the layer in the center of the load between the left side and right side boxes.
- ⑩ Place a piece of 16- by 18-inch honeycomb on top of each blood container.

*Figure 5-4. Twelve blood containers rigged (continued)*



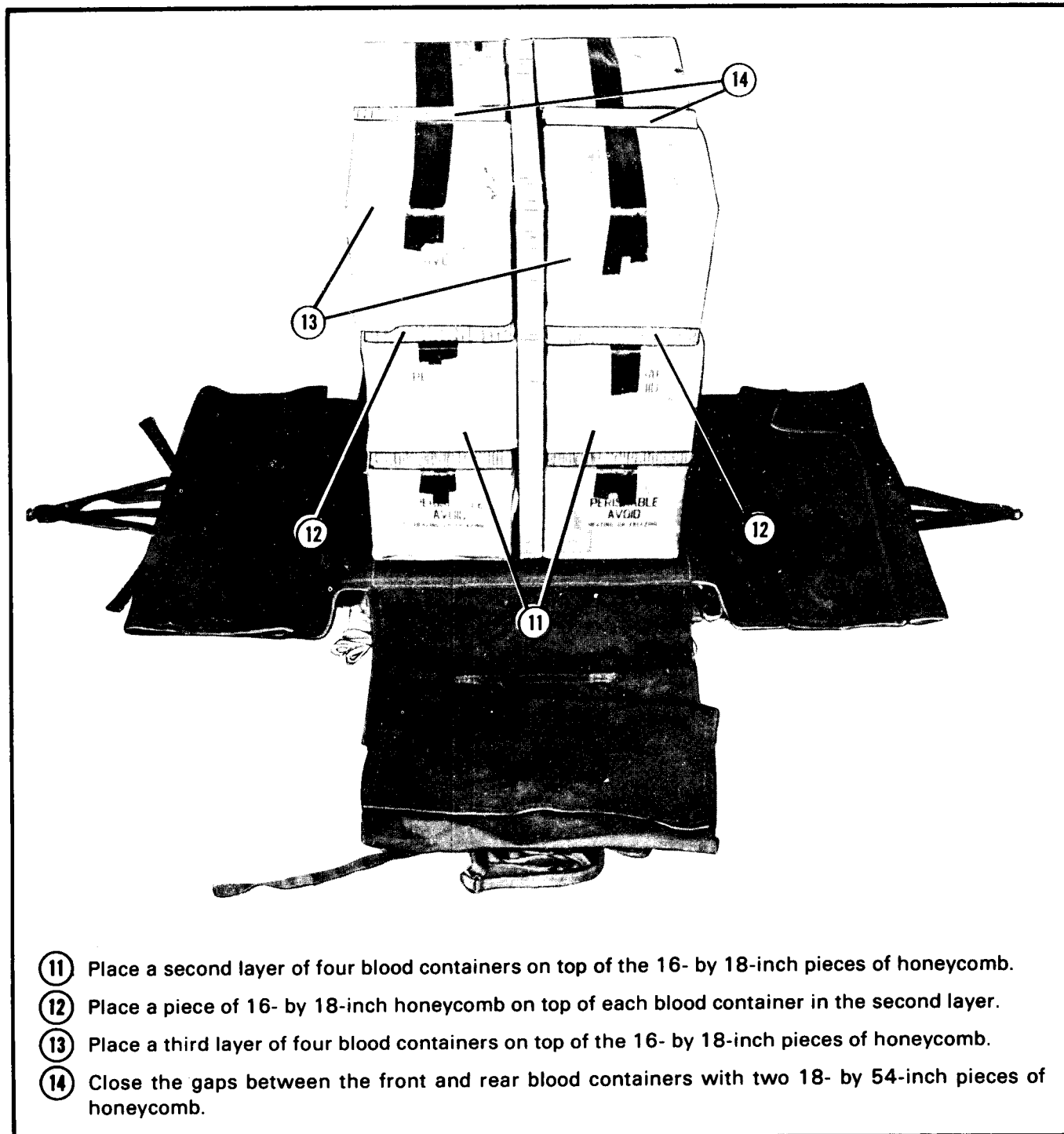

- ⑪ Place a second layer of four blood containers on top of the 16- by 18-inch pieces of honeycomb.
- ⑫ Place a piece of 16- by 18-inch honeycomb on top of each blood container in the second layer.
- ⑬ Place a third layer of four blood containers on top of the 16- by 18-inch pieces of honeycomb.
- ⑭ Close the gaps between the front and rear blood containers with two 18- by 54-inch pieces of honeycomb.

*Figure 5-4. Twelve blood containers rigged (continued)*

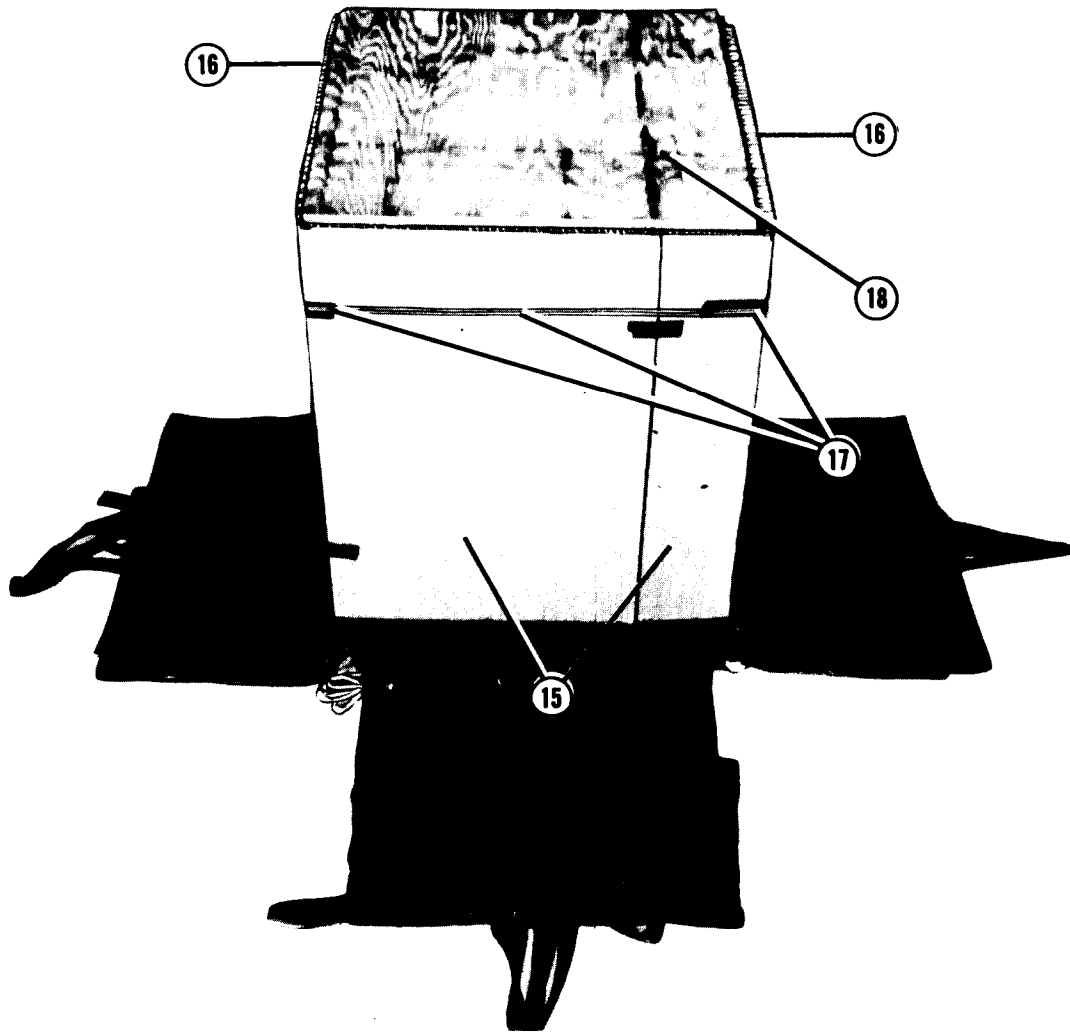

- ⑮ Tape two 36- by 54-inch pieces of honeycomb to two 11- by 54-inch pieces of honeycomb to form two 47- by 54-inch layers. Place one layer on the front of the load and one layer on the rear of the load.
- ⑯ Tape two 36- by 54-inch pieces of honeycomb to two 5- by 54-inch pieces of honeycomb to form two 41- by 54-inch layers. Place one layer on the right side of the load and one layer on the left side of the load.
- ⑰ Tie all four honeycomb layers in place with type III nylon cord. Tape all edges of the honeycomb where the type III nylon cord passes.
- ⑱ Place a piece of 3/4- by 46- by 46-inch plywood on top of the load.

*Figure 5-4. Twelve blood containers rigged (continued)*

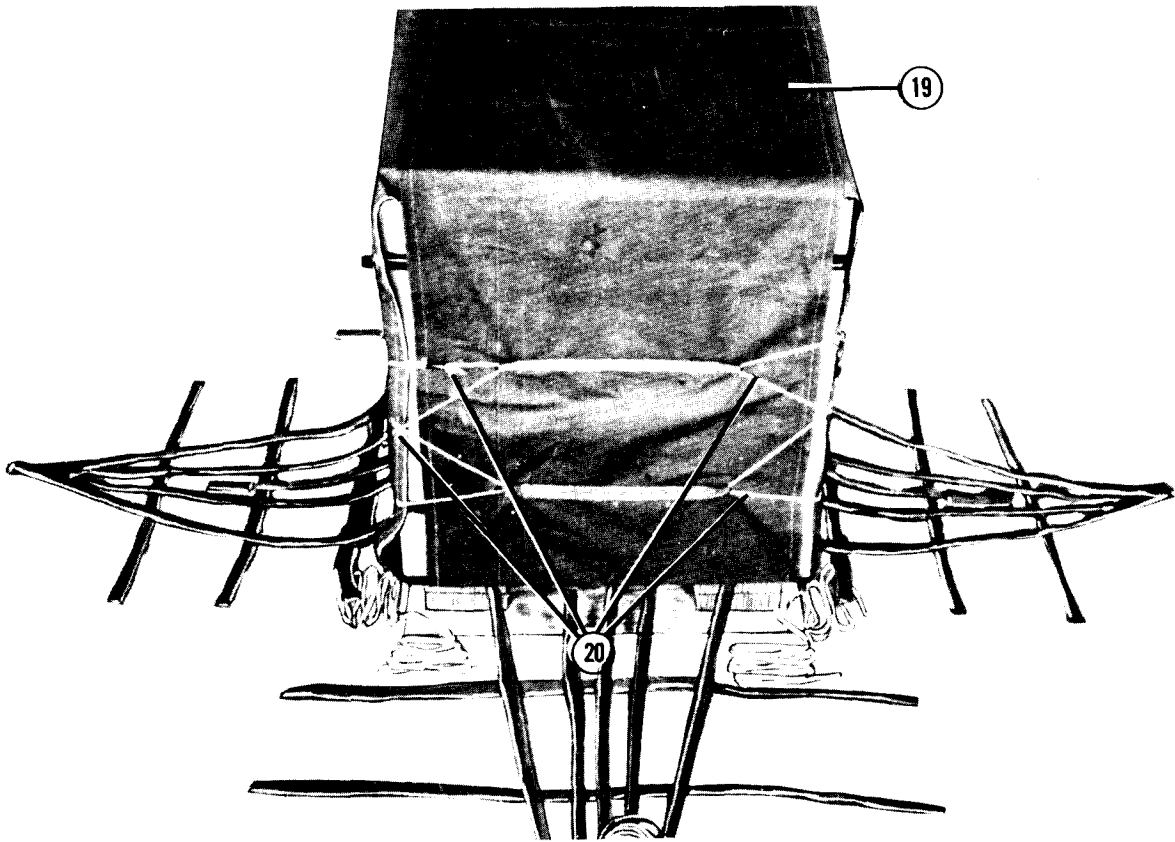

- ①9 Fold the cover up over the load.
- ②0 Pass a length of type III nylon cord through the lower cover lacing loops at each corner. Cross the type III nylon cord, and pass the ends through the upper cover lacing loops. Pull the cord tight, and tie the ends with bow knots. Tape the bow knots with adhesive tape.

*Figure 5-4. Twelve blood containers rigged (continued)*

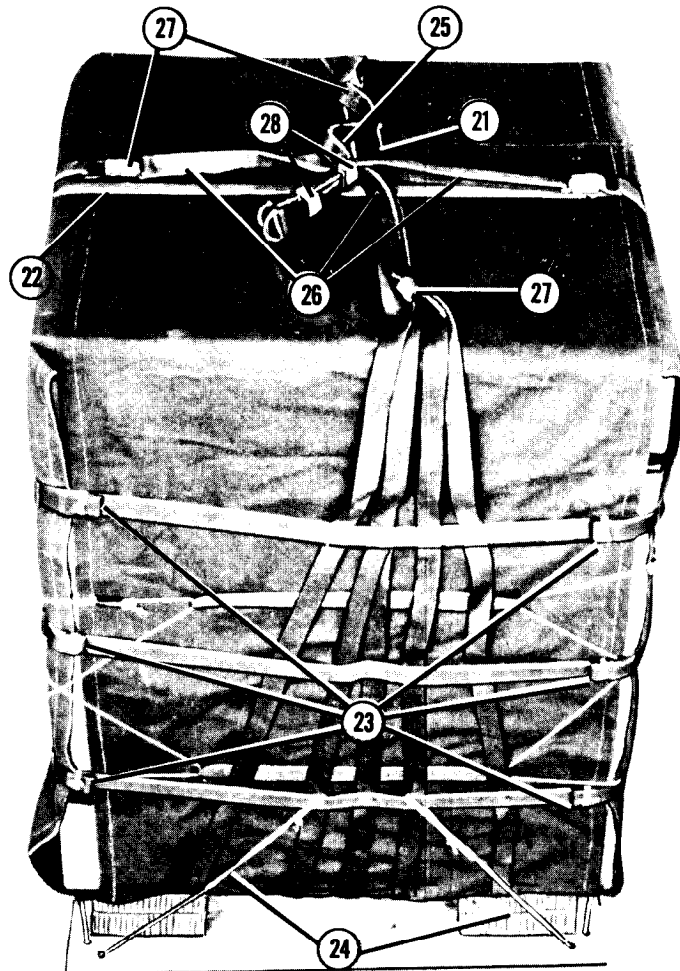

- ②1 Fasten the short tiedown strap over the top of the load with the friction adapter. Fold the excess strap, and secure the folds with 80-pound cotton webbing.
  - ②2 Fasten the long tiedown strap over the top of the load with the friction adapter. Fold the excess strap, and secure the folds with 80-pound cotton webbing.
  - ②3 Fasten the sling assembly lateral straps loosely at each corner of the load. Tighten the lateral straps at each corner. Fold the excess strap, and secure the folds with 80-pound cotton webbing.
  - ②4 Fasten the skid board to the load using the 1/2-inch tubular nylon webbing positioned in step 2.
  - ②5 Pull one of the D-rings attached to the A-22 sling assembly to the top of the load. Attach the snap fastener of one suspension web to the D-ring attached to the A-22 sling assembly.
  - ②6 Attach the other three suspension webs as described in step 25 above.
- NOTE: Make sure that all snap fasteners of the suspension web are facing inward when attached to the D-ring of the A-22 sling assembly.**
- ②7 Wrap tape around each snap fastener.
  - ②8 Tape the four suspension webs together near the free ends.

Figure 5-4. Twelve blood containers rigged (continued)

## 5-22. Stowing Cargo Parachutes

Stow one G-12D or G-12E cargo parachute on the load as shown in Figure 5-5.

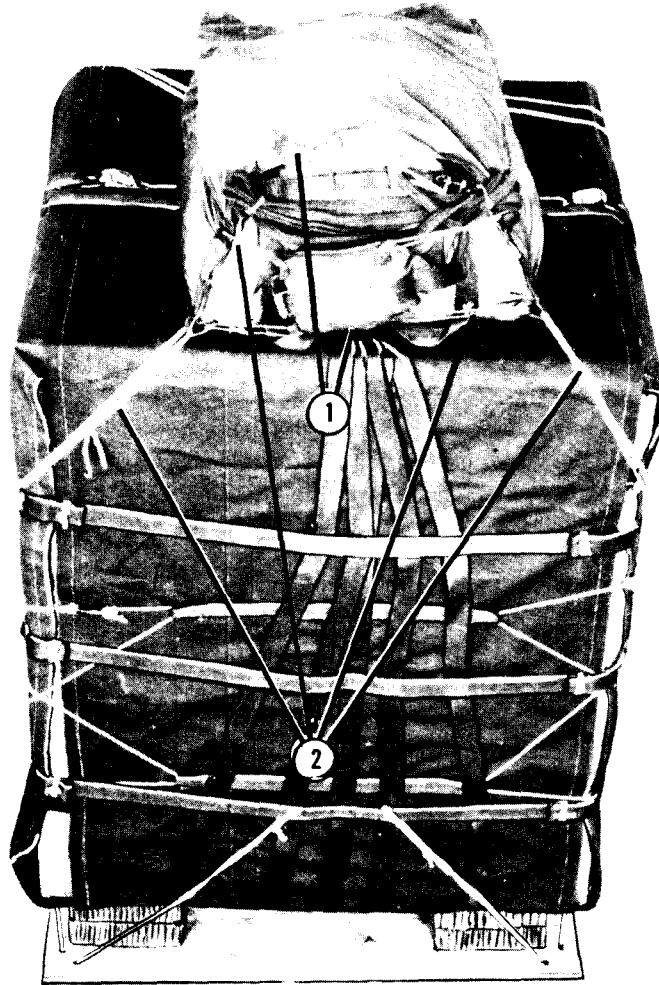

- ① Prepare the parachute according to TM 10-1670-215-23/TO 13C5-1-102 and FM 10-501/TO 13C7-1-11, and place it on top of the load.
- ② Install the parachute according to FM 10-501/TO 13C7-1-11.

*Figure 5-5. One G-12D cargo parachute stowed*

### 5-23. Marking Rigged Load

Mark the rigged load according to FM 10-501/TO 13C7-1-11 and as shown in Figure 5-6. The rigged load data must be computed for this load.

#### CAUTION

Make the final rigger inspection required by FM 10-501/TO 13C7-1-11 before the load leaves the rigging site.

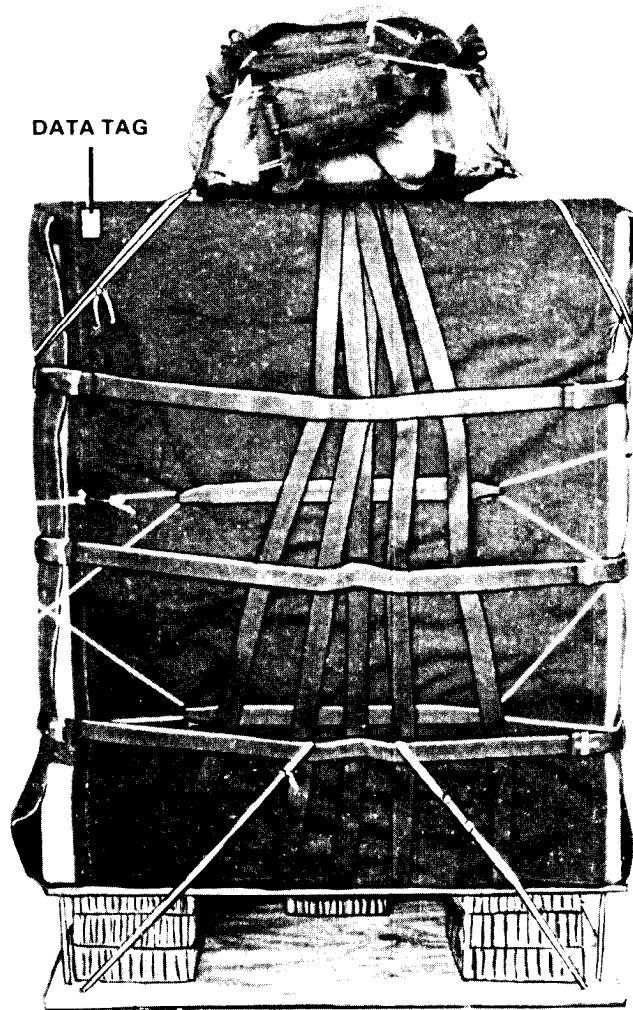

#### RIGGED LOAD DATA

Weight (with parachute).....	800 to 850 pounds
Parachute .....	G-12D or G-12E

Figure 5-6. Whole blood rigged for low-velocity airdrop in an A-22 container

**5-24. Equipment Required**

Use the equipment listed in Table 5-4 to rig this load.

*Table 5-4. Equipment required for rigging twelve blood containers for low-velocity airdrop in an A-22 container*

National Stock Number	Quantity	Item	
8040-00-273-8713	Adhesive, paste, 1-gal	As required	
1670-00-587-3421	Bag, cargo, A-22	1	
4030-00-678-8562	Clevis, suspension, 3/4-in (medium)	1	
4020-00-240-2146	Cord, nylon, type III, 550-lb	As required	
1670-00-753-3928	Pad, energy-dissipating, honeycomb,	4 sheets	
	3- by 36- by 96-in:		
	5- by 54-in		(3)
	10- by 10-in		(15)
	11- by 54-in		(2)
	16- by 18-in		(8)
	18- by 54-in		(2)
	36- by 54-in		(5)
	Parachute, cargo:		
	1670-00-893-2371		G-12D <u>or</u>
1670-01-065-3755	G-12E	1	
5530-00-128-4981	Plywood, 3/4-in:		
	46- by 46-in	1	
	48- by 48-in	2	
7510-00-266-5016	Tape, adhesive, 2-in	As required	
8310-01-102-4478	Thread, cotton, ticket number 5 <u>or</u> 8/7	As required	
8305-00-268-2411	Webbing:		
	Cotton, 80-lb	As required	
	Nylon, tubular, 1/2-in, 1,000-lb, olive drab	As required	

## GLOSSARY

---

AFB	Air Force base	in	inch
AFTO	Air Force technical order	LAPE	low-altitude parachute-extraction
attn	attention	lb	pound(s)
CB	center of balance	NCO	noncommissioned officer
CVR	centerline vertical restraint	NEACDS	naval emergency air cargo delivery
d	penny		system
DA	Department of the Army	no	number
EFTA	extraction force transfer actuator	TM	technical manual
EFTC	extraction force transfer coupling	TO	technical order
FM	field manual	TRADOC	United States Army Training and
ft	feet/foot		Doctrine Command
gal	gallon	US	United States
HQ	headquarters	w	with
HSLADS	high-speed, low-level airdrop system		



## REFERENCES

---

FM 10-500/TO 13C7-1-5	Airdrop of Supplies and Equipment: Rigging Airdrop Platforms
FM 10-501/TO 13C7-1-11	Airdrop of Supplies and Equipment: Rigging Containers
FM 10-538/TO 13C7-1-18	Airdrop of Supplies and Equipment: Rigging Naval Emergency Air Cargo Delivery System (NEACDS)
FM 10-542/TO 13C7-51-21	Airdrop of Supplies and Equipment: Rigging Loads for Special Operations
TM 10-1670-215-23/ TO 13C5-1-102	Organizational and DS Maintenance Manual Including Repair Parts and Special Tools List for Parachute, Cargo Types
TM 10-1670-268-20&P/ TO 13C7-52-22	Organizational Maintenance Manual With Repair Parts and Special Tools List: Type V Airdrop Platform
AFTO Form 22	Technical Order Publications Improvement Report
DA Form 2028	Recommended Changes to Publications and Blank Forms

By Order of the Secretaries of the Army and Air Force:

**CARL E. VUONO**  
*General United States Army*  
*Chief of Staff*

Official:

**WILLIAM J. MEEHAN II**  
*Brigadier General, United States Army*  
*The Adjutant General*

**DISTRIBUTION:**

*Active Army, USAR, and ARNG:* To be distributed in accordance with DA Form 12-11 E, Requirements for FM 10-562, Airdrop of Supplies and Equipment: Rigging Whole Blood (Qty rqr block no. 939).

**PIN: 021567-000**